

සියලු ම හිමිකම් ඇවිරිණි / முழுப் பதிப்புரிமையுடையது / All Rights Reserved

නව නිර්දේශය/புதிய பாடத்திட்டம்/New Syllabus

NEW
 இலங்கைப் பரீட்சைத் திணைக்களம் இலங்கைப் பரீட்சைத் திணைக்களம் இலங்கைப் பரීட்சைத் திணைக்களம் இலங்கைப் பரීட்சைத் திணைக்களம் இலங்கைப் பரීட்சைத் திணைக்களம்
 இலங்கைப் பரීட்சைத் திணைக்களம் இலங்கைப் பரීட்சைத் திணைக்களம் இலங்கைப் பரීட்சைத் திணைக்களம் இலங்கைப் பரීட்சைத் திணைக்களம் இலங்கைப் பரීட்சைத் திணைக்களம்
 Department of Examinations, Sri Lanka
 இலங்கைப் பரීட்சைத் திணைக்களம் இலங்கைப் பரීட்சைத் திணைக்களம் இலங்கைப் பரීட்சைத் திணைக்களம் இலங்கைப் பரīட்சைத் திணைக்களம் இலங்கைப் பரīட்சைத் திணைக்களம்
 Department of Examinations, Sri Lanka
 இலங்கைப் பரīட்சைத் திணைக்களம் இலங்கைப் பரīட்சைத் திணைக்களம் இலங்கைப் பரīட்சைத் திணைக்களம் இலங்கைப் பரīட்சைத் திணைக்களம் இலங்கைப் பரīட்சைத் திணைக்களம்
 Department of Examinations, Sri Lanka

අධ්‍යයන පොදු භාෂික පන්ති (උසස් පෙළ) විභාගය, 2019 අගෝස්තු
கல்விப் பொதுத் தராதரப் பத்திர (உயர் தர)ப் பரீட்சை, 2019 ஆகஸ்ட்
General Certificate of Education (Adv. Level) Examination, August 2019

සංයුක්ත ගණිතය I
 இணைந்த கணிதம் I
Combined Mathematics I

10 E I

05.08.2019 / 0830 - 1140

පැය තුනයි
 மூன்று மணித்தியாலம்
Three hours

අමතර කියවීමේ කාලය - මිනිත්තු 10 යි
 மேலதிக வாசிப்பு நேரம் - 10 நிமிடங்கள்
Additional Reading Time - 10 minutes

Use **additional reading time** to go through the question paper, select the questions and decide on the questions that you give priority in answering.

Index Number

Instructions:

- * This question paper consists of two parts;
Part A (Questions 1 - 10) and **Part B** (Questions 11 - 17).
- * **Part A:**
 Answer all questions. Write your answers to each question in the space provided. You may use additional sheets if more space is needed.
- * **Part B:**
 Answer five questions only. Write your answers on the sheets provided.
- * At the end of the time allotted, tie the answer scripts of the two parts together so that **Part A is on top of Part B** and hand them over to the supervisor.
- * You are permitted to remove only **Part B** of the question paper from the Examination Hall.

For Examiners' Use only

(10) Combined Mathematics I		
Part	Question No.	Marks
A	1	
	2	
	3	
	4	
	5	
	6	
	7	
	8	
	9	
	10	
B	11	
	12	
	13	
	14	
	15	
	16	
	17	
	Total	

Total	
In Numbers	
In Words	

Code Numbers	
Marking Examiner	
Checked by:	1
	2
Supervised by:	

[see page two]

Department of Examinations, Sri Lanka.

Part A

1. Using the Principle of Mathematical Induction, prove that $\sum_{r=1}^n (2r-1) = n^2$ for all $n \in \mathbb{Z}^+$.

2. Sketch the graphs of $y=|4x-3|$ and $y=3-2|x|$ in the same diagram.

Hence or otherwise, find all real values of x satisfying the inequality $|2x-3|+|x|<3$.

[see page three

Department of Examinations, Sri Lanka.

5. Show that $\lim_{x \rightarrow 3} \frac{\sqrt{x-2}-1}{\sin(\pi(x-3))} = \frac{1}{2\pi}$.

6. The region enclosed by the curves $y = \sqrt{\frac{x+1}{x^2+1}}$, $x=0$, $x=1$ and $y=0$ is rotated about the x -axis through 2π radians. Show that the volume of the solid thus generated is $\frac{\pi}{4}(\pi + \ln 4)$.

[see page five

7. Let C be the parabola parametrically given by $x = at^2$ and $y = 2at$ for $t \in \mathbb{R}$, where $a \neq 0$. Show that the equation of the normal line to the parabola C at the point $(at^2, 2at)$ is given by $y + tx = 2at + at^3$.

The normal line at the point $P \equiv (4a, 4a)$ on the parabola C meets this parabola again at a point $Q \equiv (aT^2, 2aT)$. Show that $T = -3$.

.....

.....

.....

.....

.....

.....

.....

.....

.....

.....

.....

.....

.....

.....

.....

.....

.....

.....

.....

.....

8. Let l_1 and l_2 be the straight lines given by $x + y = 4$ and $4x + 3y = 10$, respectively. Two distinct points P and Q are on the line l_1 such that the perpendicular distance from each of these points to the line l_2 is 1 unit. Find the coordinates of P and Q .

.....

.....

.....

.....

.....

.....

.....

.....

.....

.....

.....

.....

.....

.....

.....

.....

.....

.....

.....

.....

.....

[see page six

Department of Examinations, Sri Lanka.

9. Show that the point $A \equiv (-7, 9)$ lies outside the circle $S \equiv x^2 + y^2 - 4x + 6y - 12 = 0$.
 Find the coordinates of the point on the circle $S=0$ nearest to the point A .

.....

.....

.....

.....

.....

.....

.....

.....

.....

.....

.....

.....

.....

.....

.....

.....

.....

.....

.....

.....

.....

10. Let $t = \tan \frac{\theta}{2}$ for $\theta \neq (2n+1)\pi$, where $n \in \mathbb{Z}$. Show that $\cos \theta = \frac{1-t^2}{1+t^2}$.
 Deduce that $\tan \frac{\pi}{12} = 2 - \sqrt{3}$.

.....

.....

.....

.....

.....

.....

.....

.....

.....

.....

.....

.....

.....

.....

.....

.....

.....

.....

.....

.....

.....

Department of Examinations, Sri Lanka.

13. (a) Let $A = \begin{pmatrix} a & 0 & -1 \\ 0 & -1 & 0 \end{pmatrix}$, $B = \begin{pmatrix} 2 & 1 & 3 \\ 1 & -a & 4 \end{pmatrix}$ and $C = \begin{pmatrix} b & -2 \\ -1 & b+1 \end{pmatrix}$ be matrices such that

$$AB^T = C, \text{ where } a, b \in \mathbb{R}.$$

Show that $a = 2$ and $b = 1$.

Show also that, C^{-1} does not exist.

Let $P = \frac{1}{2}(C - 2I)$. Write down P^{-1} and find the matrix Q such that $2P(Q + 3I) = P - I$, where I is the identity matrix of order 2.

(b) Let $z, z_1, z_2 \in \mathbb{C}$.

Show that (i) $\operatorname{Re} z \leq |z|$, and

$$(ii) \left| \frac{z_1}{z_2} \right| = \frac{|z_1|}{|z_2|} \text{ for } z_2 \neq 0.$$

Deduce that $\operatorname{Re} \left(\frac{z_1}{z_1 + z_2} \right) \leq \frac{|z_1|}{|z_1 + z_2|}$ for $z_1 + z_2 \neq 0$.

Verify that $\operatorname{Re} \left(\frac{z_1}{z_1 + z_2} \right) + \operatorname{Re} \left(\frac{z_2}{z_1 + z_2} \right) = 1$ for $z_1 + z_2 \neq 0$,

and show that $|z_1 + z_2| \leq |z_1| + |z_2|$ for $z_1, z_2 \in \mathbb{C}$.

(c) Let $\omega = \frac{1}{2}(1 - \sqrt{3}i)$.

Express $1 + \omega$ in the form $r(\cos \theta + i \sin \theta)$; where $r (> 0)$ and $\theta \left(-\frac{\pi}{2} < \theta < \frac{\pi}{2} \right)$ are constants to be determined.

Using De Moivre's theorem, show that $(1 + \omega)^{10} + (1 + \bar{\omega})^{10} = 243$.

14. (a) Let $f(x) = \frac{9(x^2 - 4x - 1)}{(x - 3)^3}$ for $x \neq 3$.

Show that $f'(x)$, the derivative of $f(x)$, is given by $f'(x) = -\frac{9(x+3)(x-5)}{(x-3)^4}$ for $x \neq 3$.

Sketch the graph of $y = f(x)$ indicating the asymptotes, y -intercept and the turning points.

It is given that $f''(x) = \frac{18(x^2 - 33)}{(x - 3)^5}$ for $x \neq 3$.

Find the x -coordinates of the points of inflection of the graph of $y = f(x)$.

(b) The adjoining figure shows a basin in the form of a frustum of a right circular cone with a bottom. The slant length of the basin is 30 cm and the radius of the upper circular edge is twice the radius of the bottom. Let the radius of the bottom be r cm.

Show that the volume V cm³ of the basin is given by

$$V = \frac{7}{3} \pi r^2 \sqrt{900 - r^2} \text{ for } 0 < r < 30.$$

Find the value of r such that volume of the basin is maximum.

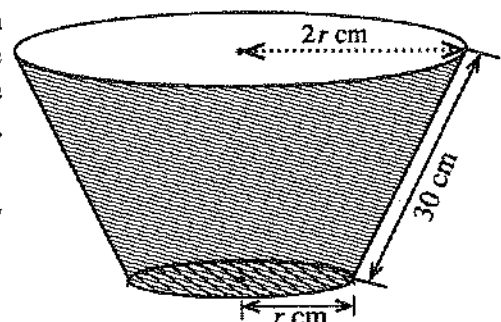

[see page nine]

15. (a) Using the substitution $x=2\sin^2\theta+3$ for $0\leq\theta\leq\frac{\pi}{4}$, evaluate $\int_3^4\sqrt{\frac{x-3}{5-x}}dx$.

(b) Using partial fractions, find $\int\frac{1}{(x-1)(x-2)}dx$.

$$\text{Let } f(t) = \int_3^t \frac{1}{(x-1)(x-2)} dx \text{ for } t > 2.$$

Deduce that $f(t) = \ln(t-2) - \ln(t-1) + \ln 2$ for $t > 2$.

Using integration by parts, find $\int \ln(x-k) dx$, where k is a real constant.

Hence, find $\int f(t) dt$.

(c) Using the formula $\int_a^b f(x) dx = \int_a^b f(a+b-x) dx$, where a and b are constants,

$$\text{show that } \int_{-\pi}^{\pi} \frac{\cos^2 x}{1+e^x} dx = \int_{-\pi}^{\pi} \frac{e^x \cos^2 x}{1+e^x} dx.$$

Hence, find the value of $\int_{-\pi}^{\pi} \frac{\cos^2 x}{1+e^x} dx$.

16. Write down the coordinates of the point of intersection A of the straight lines $12x-5y-7=0$ and $y=1$.

Let l be the bisector of the acute angle formed by these lines. Find the equation of the straight line l .

Let P be a point on l . Show that the coordinates of P can be written as $(3\lambda+1, 2\lambda+1)$, where $\lambda \in \mathbb{R}$.

Let $B \equiv (6, 0)$. Show that the equation of the circle with the points B and P as ends of a diameter can be written as $S + \lambda U = 0$, where $S \equiv x^2 + y^2 - 7x - y + 6$ and $U \equiv -3x - 2y + 18$.

Deduce that $S=0$ is the equation of the circle with AB as a diameter.

Show that $U=0$ is the equation of the straight line through B , perpendicular to l .

Find the coordinates of the fixed point which is distinct from B , and lying on the circles with the equation $S + \lambda U = 0$ for all $\lambda \in \mathbb{R}$.

Find the value of λ such that the circle given by $S=0$ is orthogonal to the circle given by $S + \lambda U = 0$.

[see page ten

17. (a) Write down $\sin(A+B)$ in terms of $\sin A$, $\cos A$, $\sin B$ and $\cos B$, and obtain a similar expression for $\sin(A-B)$.

Deduce that

$$2 \sin A \cos B = \sin(A+B) + \sin(A-B) \text{ and}$$

$$2 \cos A \sin B = \sin(A+B) - \sin(A-B).$$

Hence, solve $2 \sin 3\theta \cos 2\theta = \sin 7\theta$ for $0 < \theta < \frac{\pi}{2}$.

- (b) In a triangle ABC , the point D lies on AC such that $BD = DC$ and $AD = BC$. Let $\hat{BAC} = \alpha$ and $\hat{ACB} = \beta$. Using the Sine Rule for suitable triangles, show that $2 \sin \alpha \cos \beta = \sin(\alpha + 2\beta)$.

If $\alpha : \beta = 3 : 2$, using the last result in (a) above, show that $\alpha = \frac{\pi}{6}$.

- (c) Solve $2 \tan^{-1} x + \tan^{-1}(x+1) = \frac{\pi}{2}$. Hence, show that $\cos\left(\frac{\pi}{4} - \frac{1}{2} \tan^{-1}\left(\frac{4}{3}\right)\right) = \frac{3}{\sqrt{10}}$.

AL/2019/10/E-II(NEW)

සියලු ම හිමිකම් ඇවිරිණි/முழுப் பதிப்புரிமையுடையது/All Rights Reserved

නව නිර්දේශය/புதிய பாடத்திட்டம்/New Syllabus

NEW
 Department of Examinations, Sri Lanka
 இலங்கைப் பரீட்சைத் திணைக்களம்

අධ්‍යයන පොදු සහතික පත්‍ර (උසස් පෙළ) විභාගය, 2019 අගෝස්තු
கல்விப் பொதுத் தராதரப் பத்திர (உயர் தர)ப் பரீட்சை, 2019 ஆகஸ்ட்
General Certificate of Education (Adv. Level) Examination, August 2019

සංයුක්ත ගණිතය II
 இணைந்த கணிதம் II
Combined Mathematics II

10 E II

07.08.2019 / 0830 - 1140

පැය තුනයි
 மூன்று மணித்தியாலம்
Three hours

අමතර කියවීමේ කාලය - මිනිත්තු 10 යි
 மேலதிக வாசிப்பு நேரம் - 10 நிமிடங்கள்
Additional Reading Time - 10 minutes

Use additional reading time to go through the question paper, select the questions and decide on the questions that you give priority in answering.

Instructions:

Index Number								
--------------	--	--	--	--	--	--	--	--

- * This question paper consists of two parts;
Part A (Questions 1–10) and **Part B** (Questions 11–17)
- * **Part A:**
Answer all questions. Write your answers to each question in the space provided. You may use additional sheets if more space is needed.
- * **Part B:**
Answer five questions only. Write your answers on the sheets provided.
- * *At the end of the time allotted, tie the answer scripts of the two parts together so that **Part A** is on top of **Part B** and hand them over to the supervisor.*
- * *You are permitted to remove only **Part B** of the question paper from the Examination Hall.*
- * In this question paper, g denotes the acceleration due to gravity.

For Examiners' Use only

(10) Combined Mathematics II		
Part	Question No.	Marks
A	1	
	2	
	3	
	4	
	5	
	6	
	7	
	8	
	9	
	10	
B	11	
	12	
	13	
	14	
	15	
	16	
	17	
	Total	

Total	
In Numbers	
In Words	

Code Numbers	
Marking Examiner	
Checked by:	1
	2
Supervised by:	

[see page two

Department of Examinations, Sri Lanka.

Part A

1. Three particles A , B and C , each of mass m , are placed in that order, in a straight line on a smooth horizontal table. The particle A is given a velocity u such that it collides directly with the particle B . After colliding with the particle A , the particle B moves and collides directly with the particle C . The coefficient of restitution between A and B is e . Find the velocity of B after the first collision.

The coefficient of restitution between B and C is also e . Write down the velocity of C after its collision with B .

.....

.....

.....

.....

.....

.....

.....

.....

.....

.....

.....

.....

.....

.....

.....

.....

2. A particle is projected from a point O on a horizontal floor with a velocity whose horizontal and vertical components are \sqrt{ga} and $\sqrt{6ga}$, respectively. The particle just clears two vertical walls of heights a and b which are at a horizontal distance a apart, as shown in the figure. Show that the vertical component of the velocity of the particle when it passes the wall of height a is $2\sqrt{ga}$.

Show further that $b = \frac{5a}{2}$.

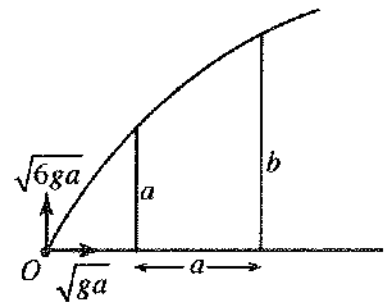

.....

.....

.....

.....

.....

.....

.....

.....

.....

.....

.....

.....

.....

.....

.....

.....

.....

.....

.....

[see page three]

Department of Examinations, Sri Lanka.

3. In the figure, A , B and C are particles of masses m , m and M , respectively. The particles A and B are connected by a light inextensible string. The particle C , lying on a smooth horizontal table, is connected to B by another light inextensible string passing over a smooth small pulley fixed at the edge of the table. The particles and the strings all lie in the same vertical plane. The system is released from rest with the strings taut. Write down equations sufficient to determine the tension of the string joining A and B .

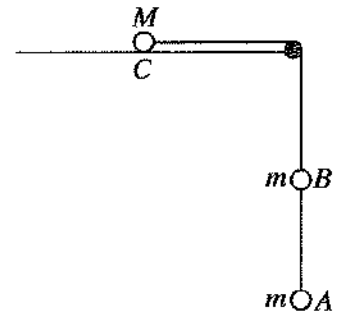

4. A car of mass M kg and constant power P kW moves downwards along a straight road of inclination α to the horizontal. There is a constant resistance of $R (> Mg \sin \alpha)$ N to its motion. At a certain instant, the acceleration of the car is a m s^{-2} . Find the velocity of the car at this instant.

Deduce that the constant speed with which the car can move downwards along the road is

$$\frac{1000P}{R - Mg \sin \alpha} \text{ m s}^{-1}.$$

5. Two particles, A and B , each of mass m , attached to the two ends of a light inextensible string which passes over a smooth fixed pulley, hang in equilibrium. A small bead C , also of mass m , released from rest from a point at a distance a vertically above A , moves freely under gravity and collides and coalesces with A . (See the figure.) Write down equations sufficient to determine the impulse of the string at the instant of the collision between A and C , and the velocity acquired by B just after the above collision.

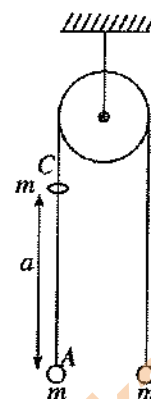

.....

.....

.....

.....

.....

.....

.....

.....

.....

.....

.....

.....

.....

.....

.....

.....

.....

.....

.....

.....

.....

.....

.....

.....

6. In the usual notation, let $2\mathbf{i} + \mathbf{j}$ and $3\mathbf{i} - \mathbf{j}$ be the position vectors of two points A and B , respectively, with respect to a fixed origin O . Find the position vectors of the two distinct points C and D such that $\widehat{AOC} = \widehat{AOD} = \frac{\pi}{2}$ and $OC = OD = \frac{1}{3} AB$.

.....

.....

.....

.....

.....

.....

.....

.....

.....

.....

.....

.....

.....

.....

.....

.....

.....

.....

.....

.....

.....

.....

.....

Department of Examinations, Sri Lanka.

7. A particle P of weight W , suspended from a horizontal ceiling by two light inextensible strings AP and BP making angles α and $\frac{\pi}{3}$ with the horizontal, respectively, is in equilibrium as shown in the figure. Find the tension in the string AP in terms of W and α .

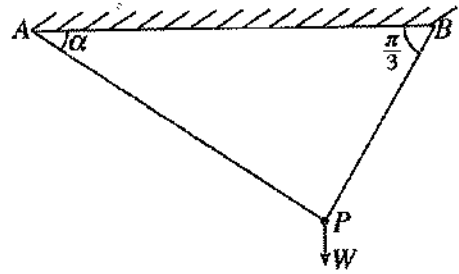

Hence, find the minimum value of this tension and the corresponding value of α .

8. A uniform rod AB of length $2a$ and weight W has its end A placed on a rough horizontal floor and the end B against a smooth vertical wall. The rod is kept in equilibrium in a vertical plane perpendicular to the wall by a horizontal force of magnitude P applied at the end A towards the wall. In the figure, F and R denote the frictional force and the normal reaction at A , respectively. If the reaction at B from the wall is $\frac{W}{2}$ as shown in the figure and the coefficient of friction between the rod and the floor is $\frac{1}{4}$, show that $\frac{W}{4} \leq P \leq \frac{3W}{4}$.

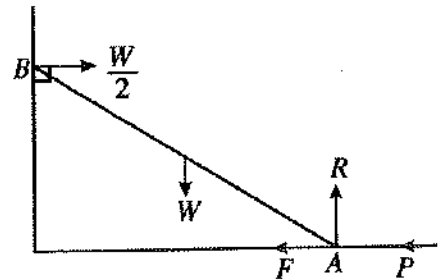

[see page six

9. Let A and B be two events of a sample space Ω . In the usual notation, it is given that $P(A) = \frac{3}{5}$, $P(A \cap B) = \frac{2}{5}$ and $P(A' \cap B) = \frac{1}{10}$. Find $P(B)$ and $P(A' \cap B')$; where A' and B' denote complementary events of A and B , respectively.

.....

.....

.....

.....

.....

.....

.....

.....

.....

.....

.....

.....

.....

.....

.....

.....

.....

.....

.....

.....

.....

.....

.....

.....

.....

10. Five positive integers each of which is less than 5, have two modes, one of which is 3. Their mean, and median are both equal to 3. Find these five integers.

.....

.....

.....

.....

.....

.....

.....

.....

.....

.....

.....

.....

.....

.....

.....

.....

.....

.....

.....

.....

.....

.....

.....

.....

**

[see page seven

Department of Examinations, Sri Lanka.

නව නිර්දේශය / புதிய பாடத்திட்டம் / New Syllabus

NEW

ශ්‍රී ලංකා විභාග දෙපාර්තමේන්තුව ශ්‍රී ලංකා විභාග දෙපාර්තමේන්තුව ශ්‍රී ලංකා විභාග දෙපාර්තමේන්තුව ශ්‍රී ලංකා විභාග දෙපාර්තමේන්තුව ශ්‍රී ලංකා විභාග දෙපාර්තමේන්තුව
 திணைக்களம் இலங்கைப் பரீட்சைத் திணைக்களம் இலங்கைப் பரීட்சைத் திணைக்களம் இலங்கைப் பரීட்சைத் திணைக்களம் இலங்கைப் பரීட்சைத் திணைக்களம்
 Department of Examinations, Sri Lanka Department of Examinations, Sri Lanka Department of Examinations, Sri Lanka Department of Examinations, Sri Lanka Department of Examinations, Sri Lanka

අධ්‍යයන පොදු සහතික පත්‍ර (උසස් පෙළ) විභාගය, 2019 අගෝස්තු
கல்விப் பொதுத் தராதரப் பத்திர (உயர் தர)ப் பரீட்சை, 2019 ஓகஸ்த்
General Certificate of Education (Adv. Level) Examination, August 2019

සංයුක්ත ගණිතය	II	10 E II
இணைந்த கணிதம்	II	
Combined Mathematics	II	

Part B

* Answer five questions only.

(In this question paper, g denotes the acceleration due to gravity.)

11. (a) Two cars P and Q move with constant accelerations in the same direction along a straight road. At time $t = 0$ the velocity of P is $u \text{ ms}^{-1}$ and the velocity of Q is $(u + 9) \text{ ms}^{-1}$. The constant acceleration of P is $f \text{ ms}^{-2}$ and the constant acceleration of Q is $(f + \frac{1}{10}) \text{ ms}^{-2}$. Sketch the velocity-time graphs for
- (i) the motions of P and Q for $t \geq 0$, in the same diagram, and
 - (ii) the motion of Q relative to P for $t \geq 0$, in a separate diagram.
- Further, it is given that at time $t = 0$ the car P is 200 metres ahead of the car Q. Find the time taken by Q to overtake P.

- (b) A river of breadth a with parallel straight banks flows with uniform velocity u . In the figure, the points A, B, C and D lying on the banks are the vertices of a square. Two boats B_1 and B_2 moving with constant speed $v (> u)$ relative to water begin their journeys at the same instant from A. The boat B_1 first travels to C along AC and then to D in the direction CD upward along the river. The boat B_2 first travels to B in the direction AB downwards along the river and then to D along BD. Sketch the velocity triangles for the motions of B_1 from A to C and of B_2 from B to D in the same diagram.

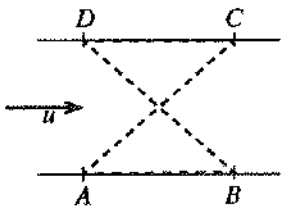

Hence, show that the speed of the boat B_1 in its motion from A to C is $\frac{1}{\sqrt{2}}(\sqrt{2v^2 - u^2} + u)$ and find the speed of the boat B_2 in its motion from B to D.

Further, show that both boats B_1 and B_2 reach D at the same instant.

12. (a) The triangles ABC and LMN in the figure, are vertical cross-sections through the centres of gravity of two identical smooth uniform wedges X and Y respectively, with $\widehat{ACB} = \widehat{LNM} = \frac{\pi}{3}$ and $\widehat{ABC} = \widehat{LMN} = \frac{\pi}{2}$ such that the faces containing BC and MN are placed on a smooth horizontal floor. The wedge X of mass $3m$ is free to move on the floor and the wedge Y is kept fixed. The lines AC and LN are the lines of greatest slope of the relevant faces. Two ends of a light inextensible string passing over two smooth small pulleys fixed at A and L, are attached to particles P and Q of masses m and $2m$, respectively. At the initial position, the particles P and Q are held on AC and LN respectively such that $AP = AL = LQ = a$ and the string taut, as in the figure. The system is released from rest. Obtain equations sufficient to determine the time taken by X to reach Y in terms of a and g .

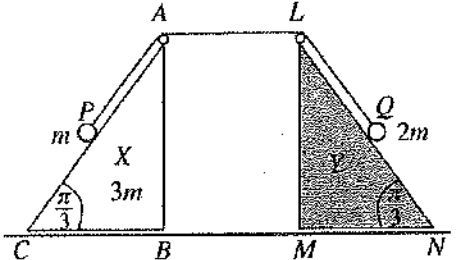

{see page eight

Department of Examinations, Sri Lanka.

(b) A smooth narrow tube $ABCDE$ is fixed in a vertical plane as shown in the figure. The portion AB of length $2\sqrt{3}a$ is straight and tangential at B to the circular portion $BCDE$ of radius $2a$. The ends A and E lie vertically above the centre O . A particle P of mass m is placed inside the tube at A and gently released from rest. Show that the speed v of the particle P when \overrightarrow{OP} makes an angle θ ($\frac{\pi}{3} < \theta < 2\pi$) with \overrightarrow{OA} is given by $v^2 = 4ga(2 - \cos \theta)$ and find the reaction on the particle P from the tube at this instant.

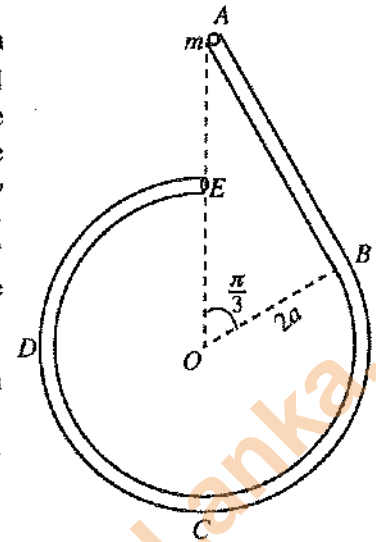

Also, find the reaction on the particle P from the tube in its motion from A to B .

Show that the reaction on the particle P from the tube changes abruptly when the particle P passes through B .

13. The points O , A and B lie in that order, with O lowermost, on a line of greatest slope of a smooth fixed plane inclined at an angle $\frac{\pi}{6}$ to the horizontal such that $OA = a$ and $AB = 2a$. One end of a light elastic string of natural length a and modulus of elasticity mg is attached to the point O and the other end to a particle P of mass m . The string is pulled along the line OAB until the particle P reaches the point B . Then the particle P is released from rest.

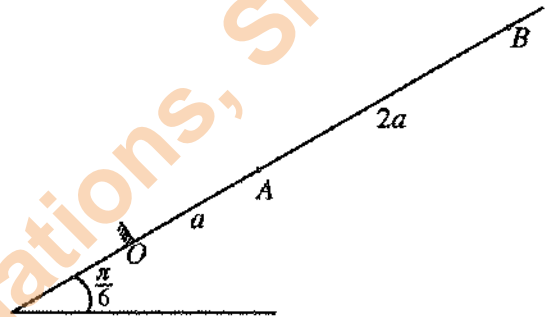

Show that the equation of motion of P from B to A is given by $\ddot{x} + \frac{g}{a}\left(x + \frac{a}{2}\right) = 0$ for $0 \leq x \leq 2a$, where $AP = x$.

Let $y = x + \frac{a}{2}$ and rewrite the above equation of motion in the form $\ddot{y} + \omega^2 y = 0$ for $\frac{a}{2} \leq y \leq \frac{5a}{2}$,

where $\omega = \sqrt{\frac{g}{a}}$.

Find the centre of the above simple harmonic motion and using the formula $\dot{y}^2 = \omega^2(c^2 - y^2)$, find the amplitude c and the velocity of P when it reaches A .

Show that the velocity of P when it reaches O is $\sqrt{7ga}$.

Show also that the time taken by P to move from B to O is $\sqrt{\frac{a}{g}} \left\{ \cos^{-1}\left(\frac{1}{5}\right) + 2k \right\}$, where $k = \sqrt{7} - \sqrt{6}$.

When the particle P reaches O , it strikes a smooth barrier fixed at O perpendicular to the plane. The coefficient of restitution between P and the barrier is e . Show that if $0 < e \leq \frac{1}{\sqrt{7}}$, then the subsequent motion of P will not be simple harmonic.

14. (a) Let $OACB$ be a parallelogram and let D be the point on AC such that $AD:DC = 2:1$. The position vectors of points A and B with respect to O are $\lambda\mathbf{a}$ and \mathbf{b} , respectively, where $\lambda > 0$. Express the vectors \overrightarrow{OC} and \overrightarrow{BD} in terms of \mathbf{a} , \mathbf{b} and λ .

Now, let \overrightarrow{OC} be perpendicular to \overrightarrow{BD} . Show that $3|\mathbf{a}|^2 \lambda^2 + 2(\mathbf{a} \cdot \mathbf{b})\lambda - |\mathbf{b}|^2 = 0$ and

find the value of λ , if $|\mathbf{a}| = |\mathbf{b}|$ and $\angle AOB = \frac{\pi}{3}$.

[see page nine

- (b) A system consists of three forces in the plane of a regular hexagon $ABCDEF$ of centre O and side of length $2a$. Forces and their points of action, in the usual notation, are shown in the table below, with the origin at O , the Ox -axis along \overrightarrow{OB} and the Oy -axis along \overrightarrow{OH} , where H is the mid-point of CD . (P is measured in newtons and a is measured in metres.)

Point of Action	Position Vector	Force
A	$a\mathbf{i} - \sqrt{3}a\mathbf{j}$	$3P\mathbf{i} + \sqrt{3}P\mathbf{j}$
C	$a\mathbf{i} + \sqrt{3}a\mathbf{j}$	$-3P\mathbf{i} + \sqrt{3}P\mathbf{j}$
E	$-2a\mathbf{i}$	$-2\sqrt{3}P\mathbf{j}$

Show that the system is equivalent to a couple and find the moment of the couple.

Now, an additional force of magnitude $6P$ N acting along \overrightarrow{FE} is introduced to this system. Find the magnitude, direction and the line of action of the single force to which the new system reduces.

15. (a) Two uniform rods AB and BC , each of length $2a$ are jointed smoothly at B . The rod AB is of weight W and the rod BC is of weight $2W$. The end A is hinged smoothly to a fixed point. This system is kept in equilibrium in a vertical plane with rods AB and BC making angles α and β , respectively, with the downward vertical by a force $\frac{W}{2}$ applied at C in the direction perpendicular to BC shown in the figure. Show that $\beta = \frac{\pi}{6}$ and find the horizontal and the vertical components of the reaction at the joint B on the rod BC exerted from the rod AB .

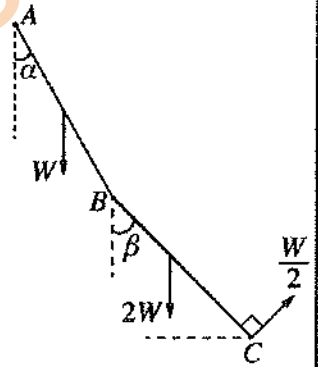

Also, show that $\tan \alpha = \frac{\sqrt{3}}{9}$.

- (b) Framework shown in the figure consists of five light rods AB , BC , BD , DC and AC smoothly jointed at their ends. Here, it is given that $AB = CB = a$, $CD = 2a$ and $\hat{BAC} = \frac{\pi}{6}$. Framework is smoothly hinged at A to a fixed point. A load W is suspended at the joint D , and the framework is kept in equilibrium in a vertical plane with AC vertical and CD horizontal by a force P parallel to the rod AB , applied at the joint C in the direction shown in the figure. Draw a stress diagram, using Bow's notation, for the joints D , B , and C .

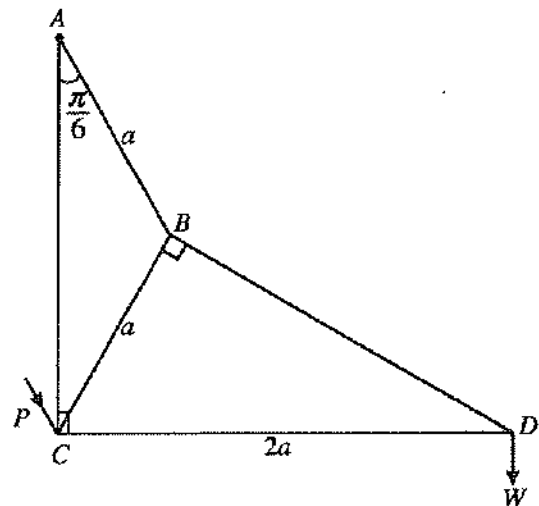

Hence, find

- the stresses in the five rods, stating whether they are tensions or thrusts, and
- the value of P .

[see page ten

16. Show that the centre of mass of

- (i) a thin uniform semi-circular wire of radius a is at a distance $\frac{2a}{\pi}$ from its centre, and
 (ii) a thin uniform hemispherical shell of radius a is at a distance $\frac{a}{2}$ from its centre.

A spoon is made by rigidly fixing, to a thin uniform hemispherical shell of centre O and radius $2a$, a thin handle $ABCD$ made of uniform wire consisting of a straight piece AB of length $2\pi a$ and a semi-circular piece BCD of radius a , such that the diameter BD is perpendicular to AB , as shown in the figure. The point A lies on the rim of the hemisphere, OA is perpendicular to AB , and OD is parallel to AB . Also, BCD lies in the plane of $OABD$. The mass per unit area of the hemisphere is σ and the mass per unit length of the handle is $\frac{a\sigma}{2}$.

Show that the centre of mass of the spoon lies at a distance $\frac{2}{19\pi}(8\pi - 2\pi^2 - 1)a$ below OA , and a distance $\frac{5}{19}a$ from the line passing through O and D .

The spoon is placed on a rough horizontal table with the hemispherical surface touching it. The coefficient of friction between the hemispherical surface and the table is $\frac{1}{7}$. Show that the spoon can be kept in equilibrium with OD vertical by a horizontal force applied at A in the direction of \vec{AO} .

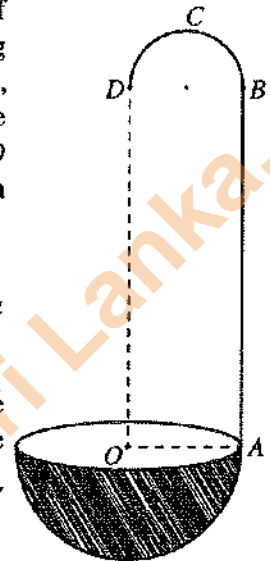

- 17.(a) Initially a box contains 3 balls identical in all aspects except for their colour, each of which is either white or black. Now, one white ball identical to balls in the box in all aspects except for its colour, is added into the box and then one ball is drawn at random from the box. Assuming that the four possible initial compositions of the balls in the box are equally likely, find the probability that
- (i) the ball drawn is white, and
 (ii) initially there were exactly 2 black balls in the box, given that the ball drawn is white.
- (b) Let the mean and the standard deviation of the set of values $\{x_i; i = 1, 2, \dots, n\}$ be μ and σ respectively. Find the mean and the standard deviation of the set of values $\{\alpha x_i; i = 1, 2, \dots, n\}$, where α is a constant.

Monthly salaries of 50 employees at a certain company are summarised in the following table:

Monthly Salary (in thousand rupees)	Number of Employees
5 – 15	9
15 – 25	11
25 – 35	14
35 – 45	10
45 – 55	6

Estimate the mean and the standard deviation of the monthly salaries of the 50 employees.

At the beginning of a year, the monthly salary of each employee is increased by $p\%$. It is given that the mean of the new monthly salaries of the above 50 employees is 29 172 rupees. Estimate the value of p and the standard deviation of the new monthly salaries of the 50 employees.

G.C.E. (A.L.) Examination - 2019
10 - Combined Mathematics II
(New Syllabus)

Distribution of Marks

Paper II

$$\text{Part A : } 10 \times 25 = 250$$

$$\text{Part B : } 05 \times 150 = 750$$

$$\text{Total} = 1000 / 10$$

$$\text{Paper II Final Mark} = 100$$

1. Three particles A , B and C , each of mass m , are placed in that order, in a straight line on a smooth horizontal table. The particle A is given a velocity u such that it collides directly with the particle B . After colliding with the particle A , the particle B moves and collides directly with the particle C . The coefficient of restitution between A and B is e . Find the velocity of B after the first collision.

The coefficient of restitution between B and C is also e . Write down the velocity of C after its collision with B .

Applying $I = \Delta(mv)$,

for A and B (1st collision) \rightarrow :

$$0 = mv + mw - mu \quad (5)$$

$$\Rightarrow v + w = u \quad (i)$$

Newton's law of restitution :

$$v - w = eu \quad (ii) \quad (5)$$

$$\therefore (i) + (ii) \Rightarrow v = \frac{(1 + e)}{2} u \quad (5)$$

$$\therefore \text{velocity of } B \text{ after 1}^{\text{st}} \text{ collision} = \frac{1}{2}(1 + e) u.$$

$$\text{Replacing } u \text{ by } v, \text{ we get the velocity of } C \text{ after its collision with } B = \frac{1}{2}(1 + e) v \quad (5)$$

$$= \frac{1}{4}(1 + e)^2 u \quad (5)$$

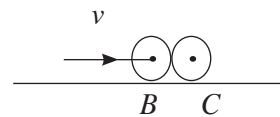
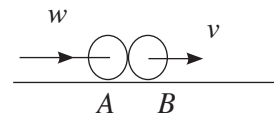
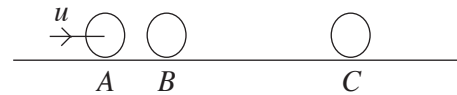

2. A particle is projected from a point O on a horizontal floor with a velocity whose horizontal and vertical components are \sqrt{ga} and $\sqrt{6ga}$, respectively. The particle just clears two vertical walls of heights a and b which are at a horizontal distance a apart, as shown in the figure. Show that the vertical component of the velocity of the particle when it passes the wall of height a is $2\sqrt{ga}$. Show further that $b = \frac{5a}{2}$.

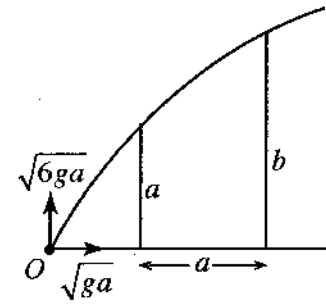

Suppose that the particle passes the wall of height a with vertical velocity component v .

From O to A , $\uparrow v^2 = u^2 + 2as$:

$$v^2 = 6ga - 2g \cdot a = 4ga \quad (5)$$

$$\therefore v = 2\sqrt{ga} \quad (5)$$

If it passes the second wall, after a further time T , then by applying

$$s = ut + \frac{1}{2}at^2 \quad \text{from } A \text{ to } B, \rightarrow \text{ and } \uparrow, \text{ we get}$$

$$a = \sqrt{ga} \cdot T, \quad (5)$$

$$\text{and } b - a = 2\sqrt{ga} \cdot T - \frac{1}{2}gT^2 \quad (5)$$

$$\text{Eliminating } T : b - a = 2\sqrt{ga} \cdot \sqrt{\frac{a}{g}} - \frac{1}{2}g \cdot \frac{a}{g}$$

$$\therefore b = a + 2a - \frac{a}{2}$$

$$\text{i.e. } b = \frac{5a}{2} \quad (5)$$

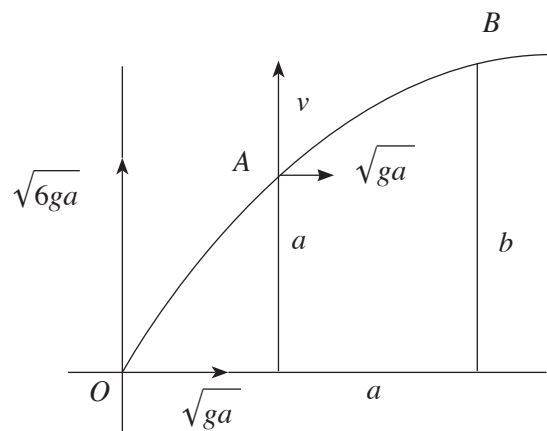

25

3. In the figure, A , B and C are particles of masses m , m and M , respectively. The particles A and B are connected by a light inextensible string. The particle C , lying on a smooth horizontal table, is connected to B by another light inextensible string passing over a smooth small pulley fixed at the edge of the table. The particles and the strings all lie in the same vertical plane. The system is released from rest with the strings taut. Write down equations sufficient to determine the tension of the string joining A and B .

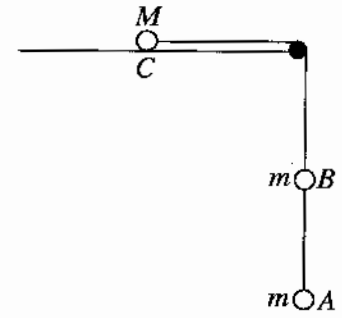

Applying $\underline{F} = m\underline{a}$

For A , $\downarrow \quad mg - T = mf \quad (5)$

For B , $\downarrow \quad T + mg - T_1 = mf, \quad (5)$

For C , $\rightarrow \quad T_1 = Mf \quad (5)$

Forces (5)

Accelerations (5)

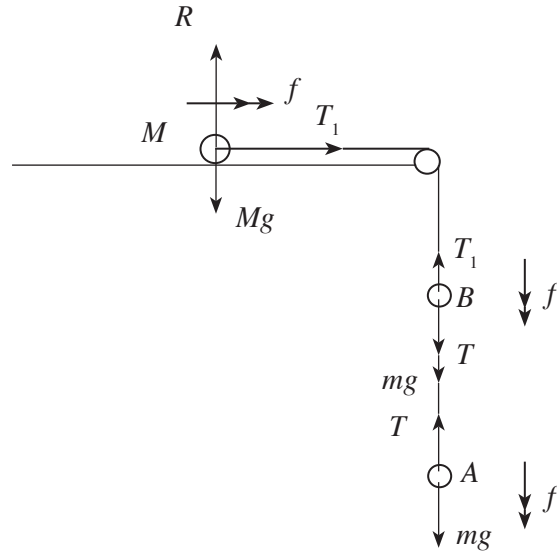

25

4. A car of mass M kg and constant power P kW moves downwards along a straight road of inclination α to the horizontal. There is a constant resistance of $R (> Mg \sin \alpha)$ N to its motion. At a certain instant, the acceleration of the car is a m s^{-2} . Find the velocity of the car at this instant.

Deduce that the constant speed with which the car can move downwards along the road is

$$\frac{1000P}{R - Mg \sin \alpha} \text{ m s}^{-1}.$$

When the speed of the car is v m s^{-1}

$$\text{tractive force } F = \frac{1000P}{v} \quad (5)$$

At the instant when the acceleration is a m s^{-2} ,

Applying $F = ma$:

$$\swarrow \quad F + Mg \sin \alpha - R = Ma. \quad (10)$$

$$\Rightarrow \frac{1000P}{v} + Mg \sin \alpha - R = Ma$$

$$\therefore v = \frac{1000P}{R - Mg \sin \alpha + Ma} \quad (5)$$

When the car is moving with constant speed,

$a = 0$ and the value of constant speed

$$v = \frac{1000P}{R - Mg \sin \alpha} \quad (5)$$

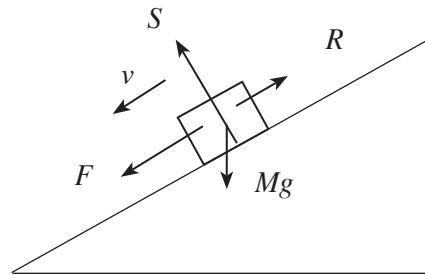

5. Two particles, A and B , each of mass m , attached to the two ends of a light inextensible string which passes over a smooth fixed pulley, hang in equilibrium. A small bead C , also of mass m , released from rest from a point at a distance a vertically above A , moves freely under gravity and collides and coalesces with A . (See the figure.) Write down equations sufficient to determine the impulse of the string at the instant of the collision between A and C , and the velocity acquired by B just after the above collision.

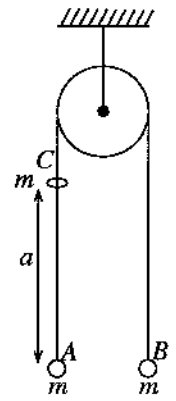

Applying $v^2 = u^2 + 2as$ ↓, the

velocity acquired by C after falling through a distance a is

$$u = \sqrt{2ga} \quad (5)$$

Let J be the impulse in the string at the instant of collision of C and A and v be the velocity of B , just after collision.

Then, applying $I = \Delta(mv)$

$$\text{for } B : \uparrow J = mv. \quad (5)$$

$$\text{For } A \text{ and } C : \downarrow -J = (m + m)v - mu. \quad (10)$$

$$\text{i.e. } -J = 2mv - m\sqrt{2ga}.$$

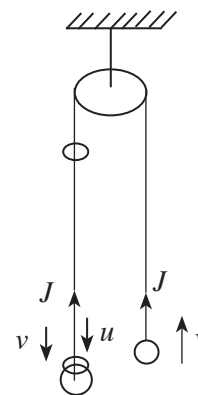

$$(5) \text{ for } v.$$

25

6. In the usual notation, let $2\mathbf{i} + \mathbf{j}$ and $3\mathbf{i} - \mathbf{j}$ be the position vectors of two points A and B , respectively, with respect to a fixed origin O . Find the position vectors of the two distinct points C and D such that $\angle AOC = \angle AOD = \frac{\pi}{2}$ and $OC = OD = \frac{1}{3}AB$.

Note that

$$\vec{OA} = 2\mathbf{i} + \mathbf{j}$$

$$\vec{OB} = 3\mathbf{i} - \mathbf{j}$$

$$\therefore \vec{AB} = \vec{AO} + \vec{OB}$$

$$= -(2\mathbf{i} + \mathbf{j}) + (3\mathbf{i} - \mathbf{j})$$

$$= \mathbf{i} - 2\mathbf{j} \quad (5)$$

$$\therefore AB = \sqrt{1+4} = \sqrt{5}$$

$$\text{Let } \vec{OC} = x\mathbf{i} + y\mathbf{j}$$

$$\text{Since } \vec{OA} \perp \vec{OC}, (2\mathbf{i} + \mathbf{j}) \cdot (x\mathbf{i} + y\mathbf{j}) = 0$$

$$\therefore y = -2x \quad (5)$$

$$\text{Since } OC = \frac{1}{3}AB, \sqrt{x^2 + 4x^2} = \frac{1}{3}\sqrt{5} \quad (5)$$

$$\therefore x^2 = \frac{1}{9}.$$

These equations are valid for the coordinates of D as well.

$$\text{So, } x = \pm \frac{1}{3}$$

$$\Rightarrow \left. \begin{matrix} x = \frac{1}{3} \\ y = -\frac{2}{3} \end{matrix} \right\} (5) \quad \left. \begin{matrix} x = -\frac{1}{3} \\ y = \frac{2}{3} \end{matrix} \right\} (5)$$

Hence the vectors C and D are $\frac{1}{3}\mathbf{i} - \frac{2}{3}\mathbf{j}$ and $-\frac{1}{3}\mathbf{i} + \frac{2}{3}\mathbf{j}$.

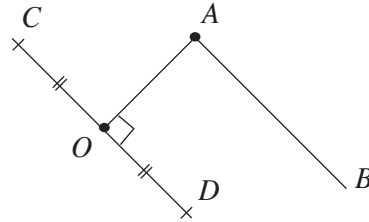

7. A particle P of weight W , suspended from a horizontal ceiling by two light inextensible strings AP and BP making angles α and $\frac{\pi}{3}$ with the horizontal, respectively, is in equilibrium as shown in the figure. Find the tension in the string AP in terms of W and α .

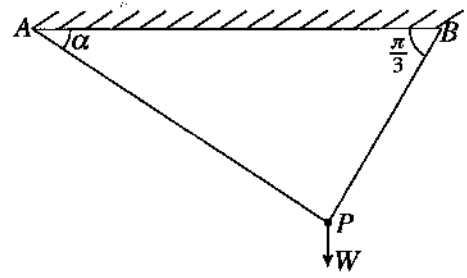

Hence, find the minimum value of this tension and the corresponding value of α .

By Lami's theorem

$$\frac{T_1}{\sin \frac{\pi}{6}} = \frac{W}{\sin \left(\frac{\pi}{2} - \alpha + \frac{\pi}{6} \right)} \quad (10)$$

$$\therefore T_1 = \frac{W}{2 \sin \left(\frac{\pi}{3} + \alpha \right)} \quad (5)$$

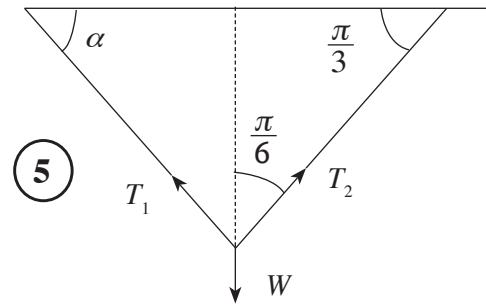

Hence the minimum value of the tension T_1 in $AP = \frac{W}{2}$, and

the value of α corresponding to minimum of T_1 is, $\alpha = \frac{\pi}{6}$. (5)

25

8. A uniform rod AB of length $2a$ and weight W has its end A placed on a rough horizontal floor and the end B against a smooth vertical wall. The rod is kept in equilibrium in a vertical plane perpendicular to the wall by a horizontal force of magnitude P applied at the end A towards the wall. In the figure, F and R denote the frictional force and the normal reaction at A , respectively. If the reaction at B from the wall is $\frac{W}{2}$ as shown in the figure and the coefficient of friction between the rod and the floor is $\frac{1}{4}$, show that $\frac{W}{4} \leq P \leq \frac{3W}{4}$.

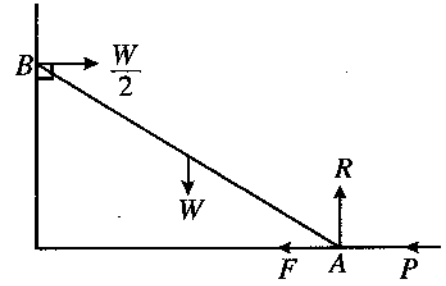

For the equilibrium of the rod :

$$\text{Resolving } \uparrow R - W = 0. \quad (5)$$

$$\leftarrow P + F - \frac{W}{2} = 0. \quad (5)$$

$$\therefore F = \frac{W}{2} - P \quad (5)$$

$\therefore |F| \leq \mu R$, we have

$$(5)$$

$$\left| \frac{W}{2} - P \right| \leq \frac{1}{4} W$$

$$\Rightarrow -\frac{1}{4} W \leq \frac{W}{2} - P \leq \frac{1}{4} W$$

$$\Rightarrow \frac{W}{4} \leq P \leq \frac{3W}{4} \quad (5)$$

25

9. Let A and B be two events of a sample space Ω . In the usual notation, it is given that $P(A) = \frac{3}{5}$, $P(A \cap B) = \frac{2}{5}$ and $P(A' \cap B) = \frac{1}{10}$. Find $P(B)$ and $P(A' \cap B')$; where A' and B' denote complementary events of A and B , respectively.

$$P(B) = P((A \cap B) \cup (A' \cap B)) = P(A \cap B) + P(A' \cap B) \quad (5)$$

$$= \frac{2}{5} + \frac{1}{10}.$$

$$\therefore P(B) = \frac{1}{2}. \quad (5)$$

$$P(A' \cap B') = P((A \cup B)')$$

$$= 1 - P(A \cup B) \quad (5)$$

$$= 1 - [P(A) + P(B) - P(A \cap B)] \quad (5)$$

$$= 1 - \left[\frac{3}{5} + \frac{1}{2} - \frac{2}{5} \right]$$

$$= 1 - \frac{7}{10}$$

$$\therefore P(A' \cap B') = \frac{3}{10} \quad (5)$$

25

10. Five positive integers each of which is less than 5, have two modes, one of which is 3. Their mean, and median are both equal to 3. Find these five integers.

With median = 3, and two distinct modes, five numbers which are less five, in ascending order can be arranged in the following two possible ways.

$$a, a, 3, 3, 4 \quad (5)$$

$$b, 3, 3, 4, 4 \quad (5)$$

Since their sum is 15 as the mean is 3,

$$\text{we have, } 2a + 10 = 15 ; a = \frac{5}{2}, \# \quad (5)$$

$$\text{or } b + 14 = 15 ; b = 1. \quad (5)$$

$$\therefore \text{ Five numbers are } 1, 3, 3, 4, 4 \quad (5)$$

25

11. (a) Two cars P and Q move with constant accelerations in the same direction along a straight road. At time $t = 0$ the velocity of P is $u \text{ m s}^{-1}$ and the velocity of Q is $(u + 9) \text{ m s}^{-1}$. The constant acceleration of P is $f \text{ m s}^{-2}$ and the constant acceleration of Q is $(f + \frac{1}{10}) \text{ m s}^{-2}$.

Sketch the velocity-time graphs for

- (i) the motions of P and Q for $t \geq 0$, in the same diagram, and
- (ii) the motion of Q relative to P for $t \geq 0$, in a separate diagram.

Further, it is given that at time $t = 0$ the car P is 200 metres ahead of the car Q . Find the time taken by Q to overtake P .

(b) A river of breadth a with parallel straight banks flows with uniform velocity u . In the figure, the points A, B, C and D lying on the banks are the vertices of a square. Two boats B_1 and B_2 moving with constant speed $v (> u)$ relative to water begin their journeys at the same instant from A . The boat B_1 first travels to C along \overrightarrow{AC} and then to D in the direction \overrightarrow{CD} upward along the river. The boat B_2 first travels to B in the direction \overrightarrow{AB} downwards along the river and then to D along \overrightarrow{BD} . Sketch the velocity triangles for the motions of B_1 from A to C and of B_2 from B to D in the same diagram.

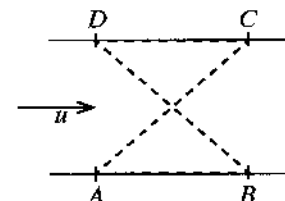

Hence, show that the speed of the boat B_1 in its motion from A to C is $\frac{1}{\sqrt{2}}(\sqrt{2v^2 - u^2} + u)$ and find the speed of the boat B_2 in its motion from B to D .

Further, show that both boats B_1 and B_2 reach D at the same instant.

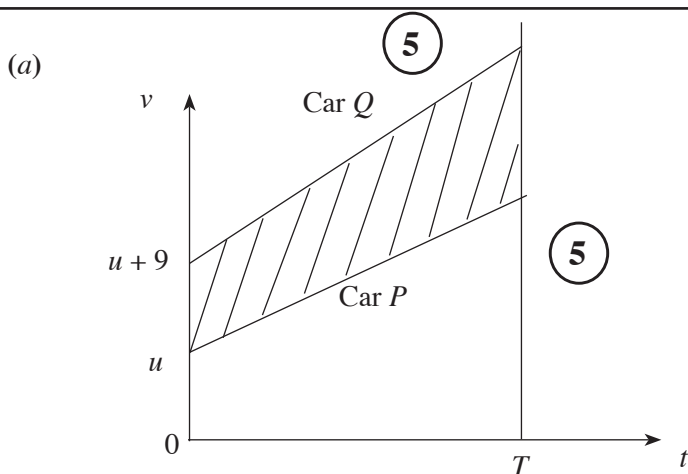

10

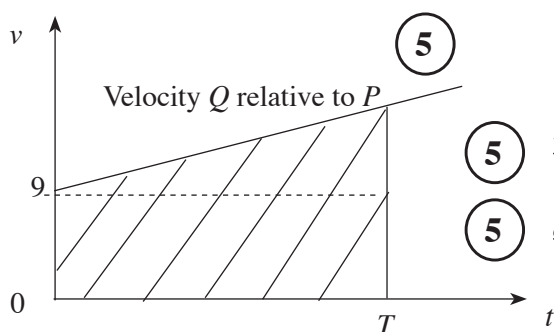

(5) $v(Q, P) = (u + 9) - u = 9.$

(5) $a(Q, P) = (f + \frac{1}{10}) - f = \frac{1}{10}.$

15

At time $t = 0$, car P is 200m ahead of Q .

In either of the graph, the area of shaded region = 200. (5)

Let T be the time taken by Q to overtake P .

$$\therefore \frac{1}{2} T (9 + 9 + \frac{1}{10} T) = 200 \quad (5)$$

$$\Rightarrow T^2 + 180 T - 4000 = 0 \quad (5)$$

$$\Rightarrow (T - 20)(T + 200) = 0$$

Since $T > 0$, $T = 20$. (5)

25

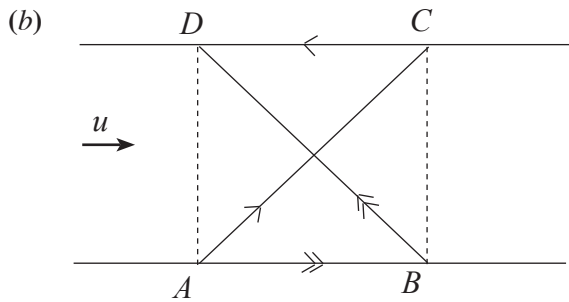

Note that

$$\mathbf{V}(B_1, E) = \angle \frac{\pi}{4}, \quad (5) \quad \mathbf{V}(B_2, E) = \angle \frac{\pi}{4} \quad (5)$$

$$\mathbf{V}(W, E) = \rightarrow u, \quad (5)$$

$$\mathbf{V}(B_i, W) = v, \text{ for } i = 1, 2.$$

$$\mathbf{V}(B_i, E) = \mathbf{V}(B_i, W) + \mathbf{V}(W, E) \quad (10)$$

$$= \mathbf{V}(W, E) + \mathbf{V}(B_i, W)$$

$$= \vec{PQ} + \vec{QR}_i \quad i = 1, 2$$

$$= \vec{PR}_i, \quad i = 1, 2$$

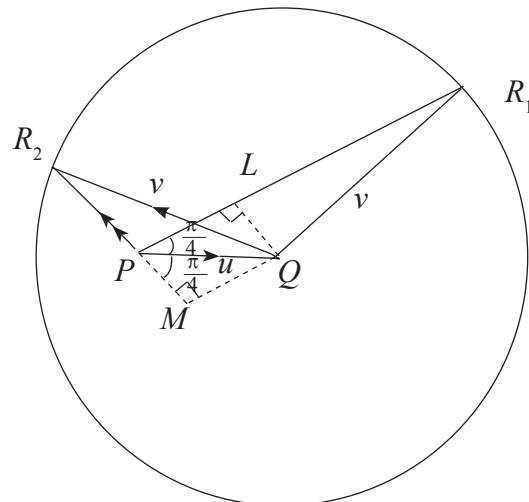

(15) + (15)

55

In ΔPQR_1 ,

$$PR_1 = PL + LR_1$$

$$= \frac{u}{\sqrt{2}} + \sqrt{v^2 - \left(\frac{u}{\sqrt{2}}\right)^2}$$

$$= \frac{1}{\sqrt{2}} \left[\sqrt{2v^2 - u^2} + u \right] \quad (10)$$

Hence the speed of B_1 , from A to C is $\frac{1}{\sqrt{2}} \left(\sqrt{2v^2 - u^2} + u \right)$

In ΔPQR_2 ,

$$\begin{aligned} PR_2 &= MR_2 - MP = \sqrt{v^2 - \left(\frac{u}{\sqrt{2}}\right)^2} - \frac{u}{\sqrt{2}} \\ &= \frac{1}{\sqrt{2}} \left(\sqrt{2v^2 - u^2} - u \right) \end{aligned} \quad (10)$$

20

Time taken by B_1 for its motion from A to C along \vec{AC} and then from C to D along \vec{CD} is

$$T_1 = \frac{a\sqrt{2}}{PR_1} + \frac{a}{v-u} \quad (5)$$

Time taken by B_2 for its motion from A to B along \vec{AB} and then from B to D along \vec{BD} is

$$T_2 = \frac{a}{v+u} + \frac{a\sqrt{2}}{PR_2} \quad (5)$$

$$T_2 - T_1 = a\sqrt{2} \left(\frac{1}{PR_2} - \frac{1}{PR_1} \right) - a \left(\frac{1}{v-u} - \frac{1}{v+u} \right) \quad (5)$$

$$= a\sqrt{2} \left(\frac{PR_1 - PR_2}{PR_1 \cdot PR_2} \right) - \frac{2au}{v^2 - u^2}$$

$$= \frac{a\sqrt{2} \cdot \sqrt{2} u}{\frac{1}{2} \left[(2v^2 - u^2) - u^2 \right]} - \frac{2au}{v^2 - u^2} \quad (5)$$

$$= \frac{2au}{v^2 - u^2} - \frac{2au}{v^2 - u^2}$$

$$= 0. \quad (5)$$

Hence, both boats B_1 and B_2 reach their destination D at the same instant.

25

12. (a) The triangles ABC and LMN in the figure, are vertical cross-sections through the centres of gravity of two identical smooth uniform wedges X and Y respectively, with $\widehat{ACB} = \widehat{LNM} = \frac{\pi}{3}$ and $\widehat{ABC} = \widehat{LMN} = \frac{\pi}{2}$ such that the faces containing BC and MN are placed on a smooth horizontal floor. The wedge X of mass $3m$ is free to move on the floor and the wedge Y is kept fixed. The lines AC and LN are the lines of greatest slope of the relevant faces. Two ends of a light inextensible string passing over two smooth small pulleys fixed at A and L , are attached to particles P and Q of masses m and $2m$, respectively. At the initial position, the particles P and Q are held on AC and LN respectively such that $AP = AL = LQ = a$ and the string taut, as in the figure. The system is released from rest. Obtain equations sufficient to determine the time taken by X to reach Y in terms of a and g .

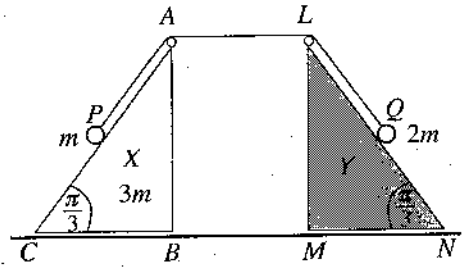

(b) A smooth narrow tube $ABCDE$ is fixed in a vertical plane as shown in the figure. The portion AB of length $2\sqrt{3}a$ is straight and tangential at B to the circular portion $BCDE$ of radius $2a$. The ends A and E lie vertically above the centre O . A particle P of mass m is placed inside the tube at A and gently released from rest. Show that the speed v of the particle P when \overrightarrow{OP} makes an angle θ ($\frac{\pi}{3} < \theta < 2\pi$) with \overrightarrow{OA} is given by $v^2 = 4ga(2 - \cos \theta)$ and find the reaction on the particle P from the tube at this instant. Also, find the reaction on the particle P from the tube in its motion from A to B . Show that the reaction on the particle P from the tube changes abruptly when the particle P passes through B .

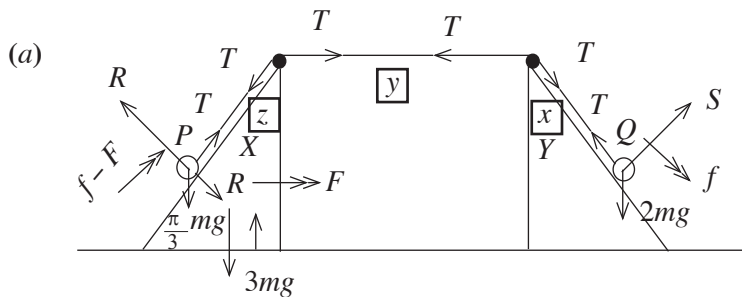
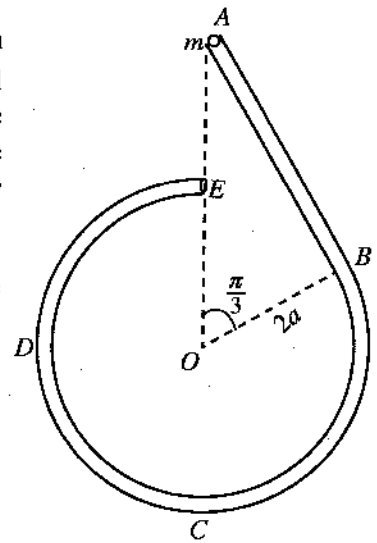

Forces (15)

Accelerations (20)

$$\begin{aligned}
 \text{Acc of } (X, E) &= \longrightarrow F \\
 \text{Acc of } (Q, E) &= \frac{\pi}{3} \text{ (} \because Y \text{ is fixed.)} \implies \ddot{x} + \ddot{y} + \ddot{z} = 0 \\
 \text{Acc of } (P, X) &= f - F \implies -\ddot{z} = \ddot{x} - (-\ddot{y}) \\
 \therefore \text{Acc of } (P, E) &= \longrightarrow F + \frac{\pi}{3} = f - F
 \end{aligned}$$

Applying $F = ma$

For motion of X and particle P ;

$$\rightarrow T = 3mF + m\left(F + \frac{f-F}{2}\right) \quad (15)$$

For motion of P ;

$$\begin{array}{c} \nearrow \\ \frac{\pi}{3} \end{array} T - mg \frac{\sqrt{3}}{2} = m \left(f - F + \frac{F}{2} \right) \quad (10)$$

For motion of Q ;

$$\begin{array}{c} \searrow \\ \frac{\pi}{3} \end{array} 2mg \frac{\sqrt{3}}{2} - T = 2mf \quad (10)$$

Time t taken by X to reach Y is given by

$$a = \frac{1}{2} F t^2 \quad (10) \quad \left(s = ut + \frac{1}{2} at^2 \rightarrow \text{for } X \right)$$

80

(b)

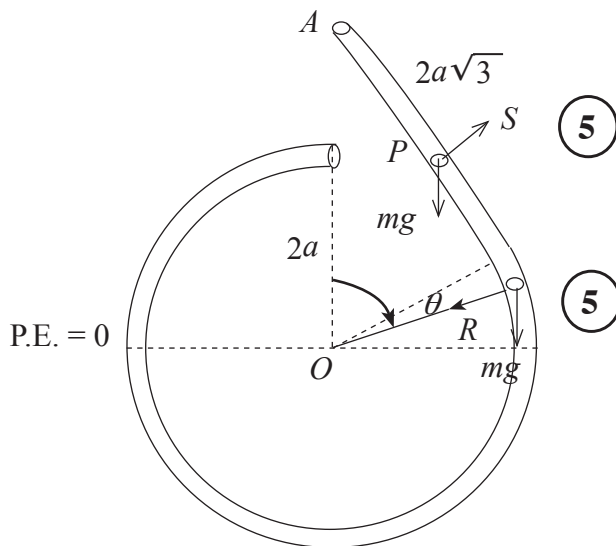

Applying the principle of conservation of energy for particle P :

$$\frac{1}{2}mv^2 + mg(2a \cos \theta) = 0 + mg \cdot 4a \quad (15)$$

$$\Rightarrow v^2 = 4ga(2 - \cos \theta), \quad \frac{\pi}{3} < \theta < 2\pi \quad (5)$$

For circular motion, inside the tube, $\mathbf{F} = m\mathbf{a}$ ↙ :

$$mg \cos \theta + R = \frac{mv^2}{2a} = 2mg(2 - \cos \theta) \quad (10) + \quad (5)$$

$$\Rightarrow R = mg(4 - 3\cos \theta) > 0 \quad \text{--- (i)} \quad (5)$$

∴ This reaction is towards the centre O .

50

For motion inside the straight tube, $F = ma \nearrow$:

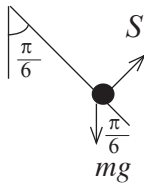

$$S - mg \cos \frac{\pi}{3} = m(0)$$

$$S = \frac{mg}{2} \quad (5)$$

The reaction just before reaching $B = \frac{mg}{2} \nearrow \quad (5)$

The reaction just after passing $B = \frac{5}{2} mg \swarrow \quad (5)$

Hence, there is an abrupt change in the reaction from $\frac{mg}{2}$ to $\frac{5}{2}mg$ in the magnitude as well as in the direction from outward to inward. (5)

20

13. The points O , A and B lie in that order, with O lowermost, on a line of greatest slope of a smooth fixed plane inclined at an angle $\frac{\pi}{6}$ to the horizontal such that $OA = a$ and $AB = 2a$. One end of a light elastic string of natural length a and modulus of elasticity mg is attached to the point O and the other end to a particle P of mass m . The string is pulled along the line OAB until the particle P reaches the point B . Then the particle P is released from rest.

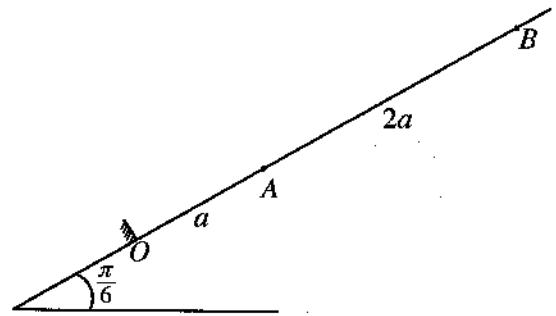

Show that the equation of motion of P from B to A is given by $\ddot{x} + \frac{g}{a} \left(x + \frac{a}{2}\right) = 0$ for $0 \leq x \leq 2a$, where $AP = x$.

Let $y = x + \frac{a}{2}$ and rewrite the above equation of motion in the form $\ddot{y} + \omega^2 y = 0$ for $\frac{a}{2} \leq y \leq \frac{5a}{2}$, where $\omega = \sqrt{\frac{g}{a}}$.

Find the centre of the above simple harmonic motion and using the formula $\dot{y}^2 = \omega^2 (c^2 - y^2)$, find the amplitude c and the velocity of P when it reaches A .

Show that the velocity of P when it reaches O is $\sqrt{7ga}$.

Show also that the time taken by P to move from B to O is $\sqrt{\frac{a}{g}} \left\{ \cos^{-1} \left(\frac{1}{5} \right) + 2k \right\}$, where $k = \sqrt{7} - \sqrt{6}$.

When the particle P reaches O , it strikes a smooth barrier fixed at O perpendicular to the plane. The coefficient of restitution between P and the barrier is e . Show that if $0 < e \leq \frac{1}{\sqrt{7}}$, then the subsequent motion of P will **not** be simple harmonic.

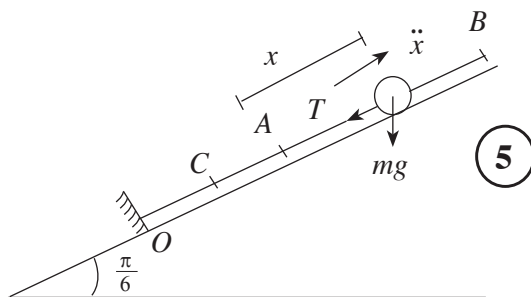

Equation of motion of P : $\underline{F} = m\underline{a}$ ↙ ;

$$T + mg \frac{1}{2} = m(-\ddot{x}) \quad \text{--- (i) } \quad \textcircled{10}$$

$$T = mg \left(\frac{x}{a} \right) \quad \text{--- (ii) } \quad \textcircled{5}$$

$$\text{(i) and (ii) } \Rightarrow \quad \ddot{x} + \frac{g}{a} \left(x + \frac{a}{2}\right) = 0, \quad 0 \leq x \leq 2a.$$

$\textcircled{5}$

$\textcircled{25}$

Writing $y = x + \frac{a}{2}$, $\ddot{y} = \ddot{x}$, we get (5)

$$\ddot{y} + \omega^2 y = 0, \quad \frac{a}{2} \leq y \leq \frac{5a}{2}, \quad (5)$$

where $\omega^2 = \frac{g}{a}$.

10

Centre C of SHM is given by $\ddot{x} = 0$. i.e. $y = 0$ or $x = \frac{-a}{2}$. (5) + (5)

So, point C on OA such that $OC = \frac{a}{2}$, (Mid - Point of OA).

Amplitude c is given by the formula

$$\dot{y}^2 = \omega^2 (c^2 - y^2), \quad \text{where } \omega^2 = \frac{g}{a}.$$

$$\dot{y} = 0 \quad \text{when } y = \frac{5a}{2} \quad (\text{at } B). \quad (5)$$

$$\therefore 0 = \omega^2 \left(c^2 - \left(\frac{5a}{2} \right)^2 \right) \Rightarrow c = \frac{5a}{2}. \quad (5)$$

Let u be the velocity when the particle reaches the point A .

$$\text{At } A \quad y = \frac{a}{2}, \quad u^2 = \frac{g}{a} \left(\left(\frac{5a}{2} \right)^2 - \left(\frac{a}{2} \right)^2 \right). \quad (5) + (5)$$

$$\Rightarrow u = \sqrt{6ga}. \quad (5)$$

35

Motion of P from A to O

This motion is under gravity on the plane.

Applying $v^2 = u^2 + 2fs$:

$$\swarrow v^2 = 6ga + 2 \left(\frac{g}{2} \right) \cdot a \quad (5)$$

$$\therefore v^2 = 7ga$$

$$\therefore v = \sqrt{7ga} \quad (5)$$

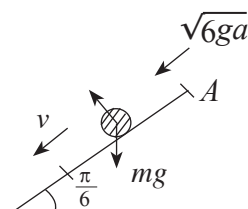

10

Time taken by P to move from B to A , under SHM

$$\omega t_1 = \alpha. \quad (5) \quad \text{Now } \cos \alpha = \frac{\frac{a}{2}}{\frac{5a}{2}} = \frac{1}{5}. \quad (5)$$

$$\therefore t_1 = \sqrt{\frac{a}{g}} \left(\cos^{-1}\left(\frac{1}{5}\right) \right). \quad (5)$$

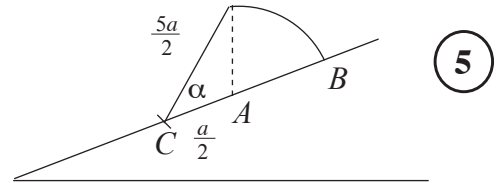

Now, time taken by P to move from A to O :

Applying $v = u + at$: (5)

$$\swarrow \sqrt{7ga} = \sqrt{6ga} + \frac{g}{2} t_2$$

$$\therefore t_2 = 2\sqrt{\frac{a}{g}} (\sqrt{7} - \sqrt{6}) \quad (5) = 2k\sqrt{\frac{a}{g}}, \text{ where } k = \sqrt{7} - \sqrt{6}.$$

\therefore Total time, from B to O is (5)

$$t_1 + t_2 = \sqrt{\frac{a}{g}} \left(\cos^{-1}\left(\frac{1}{5}\right) + 2k \right), \text{ where } k = \sqrt{7} - \sqrt{6}.$$

35

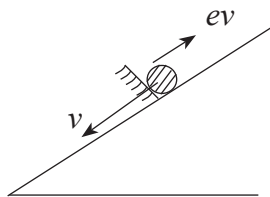

Just after striking the smooth barrier at O , speed of P is $ev = e\sqrt{7ga} \quad (5)$

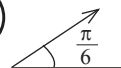

The subsequent motion of the particle will not be simple harmonic if $0 < z \leq a$, where z is the distance travelled up the plane under gravity. (10)

Applying $v^2 = u^2 + 2as$:

$$\nearrow 0 = (ev)^2 - 2\left(\frac{g}{2}\right)z \quad (5)$$

$$\Rightarrow z = 7e^2a \quad (5)$$

Now, $0 < z \leq a$

$$\Leftrightarrow 0 < 7e^2a \leq a \quad (5)$$

$$\Leftrightarrow 0 < e \leq \frac{1}{\sqrt{7}}. \quad (5)$$

35

14. (a) Let $OACB$ be a parallelogram and let D be the point on AC such that $AD:DC=2:1$. The position vectors of points A and B with respect to O are $\lambda\mathbf{a}$ and \mathbf{b} , respectively, where $\lambda > 0$. Express the vectors \vec{OC} and \vec{BD} in terms of \mathbf{a} , \mathbf{b} and λ .

Now, let \vec{OC} be perpendicular to \vec{BD} . Show that $3|\mathbf{a}|^2 \lambda^2 + 2(\mathbf{a} \cdot \mathbf{b})\lambda - |\mathbf{b}|^2 = 0$ and find the value of λ , if $|\mathbf{a}| = |\mathbf{b}|$ and $\hat{AOB} = \frac{\pi}{3}$.

(b) A system consists of three forces in the plane of a regular hexagon $ABCDEF$ of centre O and side of length $2a$. Forces and their points of action, in the usual notation, are shown in the table below, with the origin at O , the Ox -axis along \vec{OB} and the Oy -axis along \vec{OH} , where H is the mid-point of CD . (P is measured in newtons and a is measured in metres.)

Point of Action	Position Vector	Force
A	$a\mathbf{i} - \sqrt{3}a\mathbf{j}$	$3P\mathbf{i} + \sqrt{3}P\mathbf{j}$
C	$a\mathbf{i} + \sqrt{3}a\mathbf{j}$	$-3P\mathbf{i} + \sqrt{3}P\mathbf{j}$
E	$-2a\mathbf{i}$	$-2\sqrt{3}P\mathbf{j}$

Show that the system is equivalent to a couple and find the moment of the couple.

Now, an additional force of magnitude $6P$ N acting along \vec{FE} is introduced to this system. Find the magnitude, direction and the line of action of the single force to which the new system reduces.

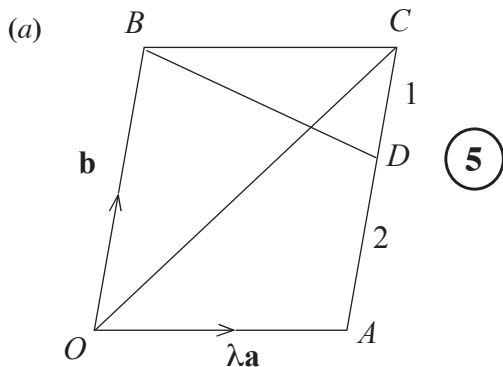

$$\vec{OC} = \vec{OB} + \vec{BC} \quad (5)$$

$$\vec{OC} = \lambda\mathbf{a} + \mathbf{b}$$

$$\begin{aligned} \vec{BD} &= \vec{BC} + \vec{CD} \\ &= \lambda\mathbf{a} + \frac{1}{3}\vec{CA} \end{aligned} \quad (5)$$

$$\vec{BD} = \lambda\mathbf{a} + -\frac{1}{3}\mathbf{b}$$

Since $\vec{OC} \perp \vec{BD}$, their scalar product = 0. (5)

$$\Rightarrow (\lambda\mathbf{a} + \mathbf{b}) \cdot (\lambda\mathbf{a} - \frac{1}{3}\mathbf{b}) = 0$$

$$\lambda^2 |\mathbf{a}|^2 + (1 - \frac{1}{3})(\mathbf{a} \cdot \mathbf{b})\lambda - \frac{1}{3} |\mathbf{b}|^2 = 0 \quad (5) \quad (\because \mathbf{b} \cdot \mathbf{a} = \mathbf{a} \cdot \mathbf{b})$$

$$\Rightarrow 3\lambda^2 |\mathbf{a}|^2 + 2(\mathbf{a} \cdot \mathbf{b})\lambda - |\mathbf{b}|^2 = 0 \quad (5)$$

Given $|\mathbf{a}| = |\mathbf{b}|$ and $\hat{AOB} = \frac{\pi}{3}$

$$\Rightarrow \mathbf{a} \cdot \mathbf{b} = |\mathbf{a}| |\mathbf{b}| \cos \frac{\pi}{3} \quad (5)$$

$$= \frac{1}{2} |\mathbf{a}|^2$$

Substituting in the above equation

$$3|a|^2\lambda^2 + 2 \cdot \frac{1}{2}|a|^2\lambda - |a|^2 = 0 \quad (5)$$

$$3\lambda^2 + \lambda - 1 = 0 \quad (5)$$

$$\lambda = \frac{-1 \pm \sqrt{1+12}}{2}$$

$$\text{since } \lambda > 0; \lambda = \frac{\sqrt{13}-1}{2} \quad (5)$$

50

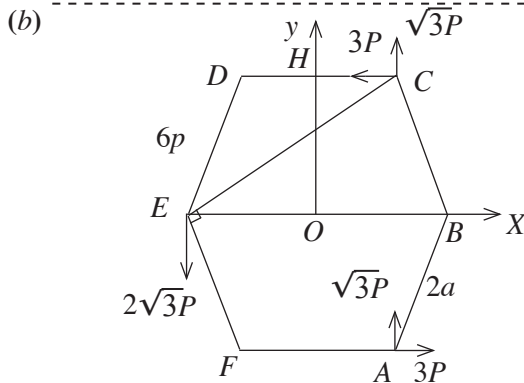

Position vectors of points of action.

$$\vec{OA} = ai - \sqrt{3} aj$$

$$\vec{OC} = ai + \sqrt{3} aj$$

$$\vec{OE} = -2ai$$

For diagram (15)

Reduce the system at O .

$$\rightarrow X = 3P - 3P = 0 \quad (10)$$

$$\uparrow Y = \sqrt{3}P + \sqrt{3}P - 2\sqrt{3}P = 0 \quad (10)$$

} System is equivalent to a couple if $M \neq 0$

$$O \curvearrowright 2 \times 3P \cdot a\sqrt{3}P + 2a\sqrt{3}P + (2a) \cdot 2\sqrt{3}P = M = 12a\sqrt{3}P \curvearrowright$$

Moment of the couple ($M \neq 0$) is (20)

of magnitude $12a\sqrt{3}P$ Nm, in the counterclockwise sense. (5) + (5)

65

New System

Magnitude = $6P$ (5)

Direction = $\frac{\pi}{3}$ (5)

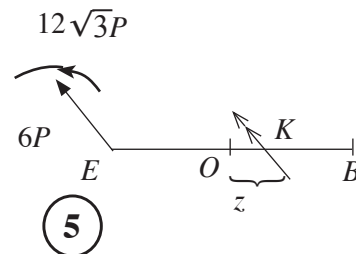

$$K \curvearrowright -6P \times (2a+z) \frac{\sqrt{3}}{2} + 12a\sqrt{3}P = 0 \quad (10)$$

$$\Rightarrow z = 2a \quad (5)$$

\therefore New system reduces to a single force acting along \vec{BC} . (5)

35

15. (a) Two uniform rods AB and BC , each of length $2a$ are jointed smoothly at B . The rod AB is of weight W and the rod BC is of weight $2W$. The end A is hinged smoothly to a fixed point. This system is kept in equilibrium in a vertical plane with rods AB and BC making angles α and β , respectively, with the downward vertical by a force $\frac{W}{2}$ applied at C in the direction perpendicular to BC shown in the figure. Show that $\beta = \frac{\pi}{6}$ and find the horizontal and the vertical components of the reaction at the joint B on the rod BC exerted from the rod AB .

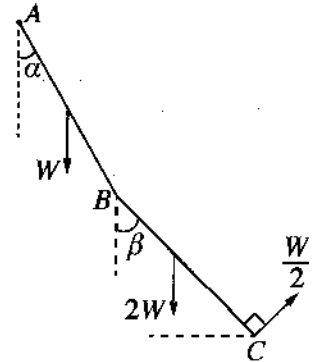

Also, show that $\tan \alpha = \frac{\sqrt{3}}{9}$.

(b) Framework shown in the figure consists of five light rods AB, BC, BD, DC and AC smoothly jointed at their ends. Here, it is given that $AB = CB = a$, $CD = 2a$ and $\hat{BAC} = \frac{\pi}{6}$. Framework is smoothly hinged at A to a fixed point. A load W is suspended at the joint D , and the framework is kept in equilibrium in a vertical plane with AC vertical and CD horizontal by a force P parallel to the rod AB , applied at the joint C in the direction shown in the figure. Draw a stress diagram, using Bow's notation, for the joints D, B , and C .

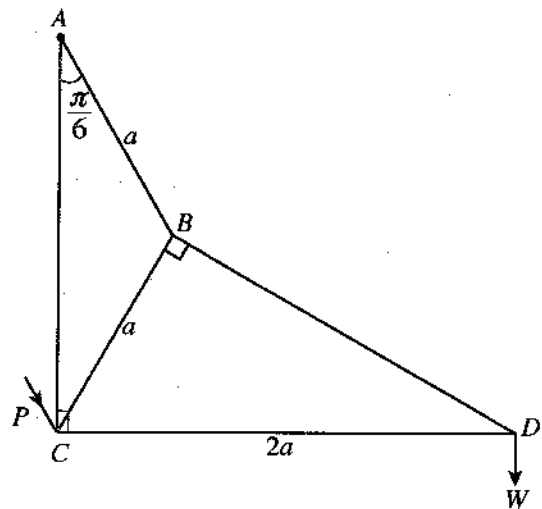

Hence, find

- (i) the stresses in the five rods, stating whether they are tensions or thrusts, and
- (ii) the value of P .

(a)

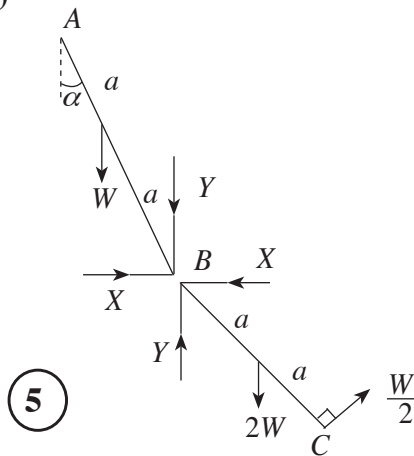

Taking moments about B for BC ,

$$B \curvearrowright \frac{W}{2} (2a) = 2W \cdot a \sin \beta \quad (10)$$

$$\Rightarrow \sin \beta = \frac{1}{2} \therefore \beta = \frac{\pi}{6} \quad (5) + (5)$$

For BC

$$\leftarrow X = \frac{W}{2} \cdot \cos \beta = \frac{\sqrt{3}}{4} W \quad (5)$$

$$\uparrow \text{ for } BC : Y = 2W - \frac{W}{2} \sin \beta \quad (5)$$

$$= \frac{7}{4} W \quad (5)$$

40

$$A \curvearrowright X \cdot 2a \cos \alpha - Y 2a \sin \alpha - W a \sin \alpha = 0 \quad (10)$$

$$\Rightarrow \sqrt{3} \cos \alpha = 9 \sin \alpha. \quad (5)$$

$$\Rightarrow \tan \alpha = \frac{\sqrt{3}}{9}. \quad (5)$$

20

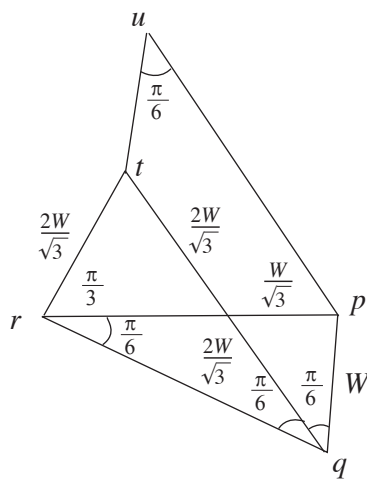
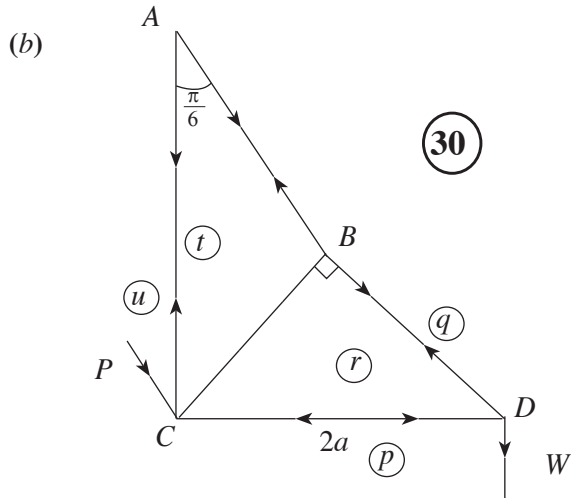

Rod	Tension	Thrust
AB	$\frac{4W}{\sqrt{3}}$	-
BC	$\frac{2W}{\sqrt{3}}$	-
AC	W	-
BD	2W	-
CD	-	$\sqrt{3} W$

50

$$P = up = \frac{4W}{\sqrt{3}} \quad (10)$$

90

16. Show that the centre of mass of

- (i) a thin uniform semi-circular wire of radius a is at a distance $\frac{2a}{\pi}$ from its centre, and
- (ii) a thin uniform hemispherical shell of radius a is at a distance $\frac{a}{2}$ from its centre.

A spoon is made by rigidly fixing, to a thin uniform hemispherical shell of centre O and radius $2a$, a thin handle $ABCD$ made of uniform wire consisting of a straight piece AB of length $2\pi a$ and a semi-circular piece BCD of radius a , such that the diameter BD is perpendicular to AB , as shown in the figure. The point A lies on the rim of the hemisphere, OA is perpendicular to AB , and OD is parallel to AB . Also, BCD lies in the plane of $OABD$. The mass per unit area of the hemisphere is σ and the mass per unit length of the handle is $\frac{a\sigma}{2}$.

Show that the centre of mass of the spoon lies at a distance $\frac{2}{19\pi}(8\pi - 2\pi^2 - 1)a$ below OA , and a distance $\frac{5}{19}a$ from the line passing through O and D .

The spoon is placed on a rough horizontal table with the hemispherical surface touching it. The coefficient of friction between the hemispherical surface and the table is $\frac{1}{7}$. Show that the spoon can be kept in equilibrium with OD vertical by a horizontal force applied at A in the direction of \vec{AO} .

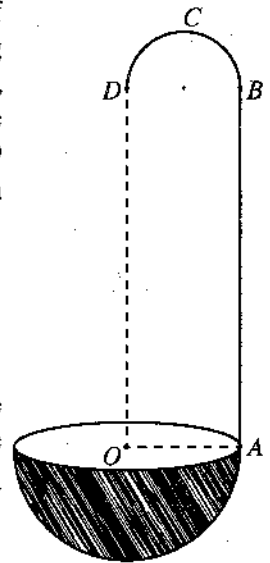

(i) Semi - circular wire

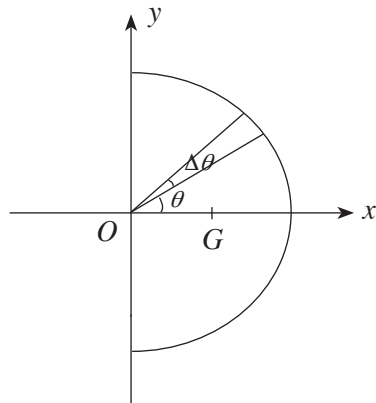

By symmetry, the centre of mass G lies on Ox - axis. 5

$$\Delta m = a\Delta\theta\rho, \text{ where } \rho \text{ is the mass per unit length}$$

Let $OG = \bar{x}$. Then

$$\begin{aligned} \bar{x} &= \frac{\int_{-\pi/2}^{\pi/2} a\rho a \cos\theta d\theta}{\int_{-\pi/2}^{\pi/2} a\rho d\theta} && \text{⑤} + \text{⑤} \\ &= \frac{a \sin\theta \Big|_{-\pi/2}^{\pi/2}}{\theta \Big|_{-\pi/2}^{\pi/2}} && \text{⑤} \\ &= \frac{2a}{\pi} && \text{⑤} \end{aligned}$$

Hence, the centre of mass is at a distance $\frac{2a}{\pi}$ from O .

25

(ii) Hemispherical shell

By symmetry, the centre of mass G lies on the Ox - axis

(5)

$\Delta m = 2\pi (a \sin \theta) a \rho \theta \cdot \sigma$ where

σ is the mass per unit area.

Let $OG = \bar{x}$. Then

$$\bar{x} = \frac{\int_0^{\frac{\pi}{2}} 2\pi (a \sin \theta) a \sigma a \cos \theta d\theta}{\int_0^{\frac{\pi}{2}} 2\pi (a \sin \theta) a \sigma d\theta} \quad (5) + (5)$$

$$= \frac{\frac{a \sin \theta}{2} \Big|_0^{\frac{\pi}{2}}}{-\cos \theta \Big|_0^{\frac{\pi}{2}}} \quad (5) + (5)$$

$$= \frac{a}{2} \cdot (5)$$

Hence, the centre of mass is at a distance $\frac{a}{2}$ from O .

30

Let $G(\bar{x}, \bar{y})$ with

Ox - axis along OA and Oy - axis along OD .

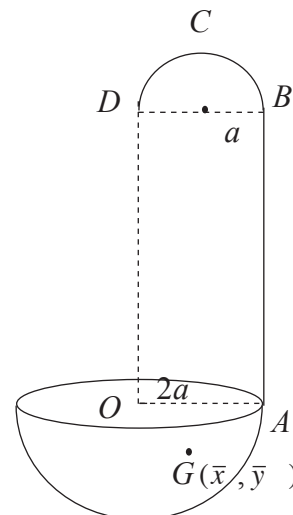

Object	Mass	Distance from $OD (\rightarrow)$	Distance from $OA (\downarrow)$
Straight piece AB	$\pi a^2 \sigma$ (5)	$2a$	πa
Semi circular piece BCD	$\frac{\pi a^2 \sigma}{2}$ (5)	a	$2\pi a + \frac{2a}{\pi}$
Hemispherical shell	$8\pi a^2 \sigma$ (5)	0	$-a$
Spoon	$\frac{19\pi a^2 \sigma}{2}$ (5)	\bar{x}	\bar{y}

$$\frac{19\pi a^2 \sigma}{2} \bar{y} = \pi a^2 \sigma \cdot \pi a + \frac{\pi a^2 \sigma}{2} \left(2\pi a + \frac{2a}{\pi}\right) + 8\pi a^2 \sigma (-a) \quad (10)$$

$$\frac{19\pi}{2} \bar{y} = -8\pi a + 2\pi a + a \quad (5)$$

$$\therefore \bar{y} = \frac{-2}{19\pi} (8\pi - 2\pi^2 - 1)a$$

\therefore centre of mass of the spoon lies at A distance

$$\frac{2}{19\pi} (8\pi - 2\pi^2 - 1) a \text{ below } OA.$$

$$\frac{19\pi a^2 \sigma}{2} \bar{x} = \pi a^2 \sigma \cdot 2a + \frac{\pi a^2 \sigma}{2} \cdot a + 8\pi a^2 \sigma \cdot 0 \quad (10)$$

$$\therefore \frac{19}{2} \bar{x} = 2a + \frac{a}{2} = \frac{5a}{2}$$

$$\therefore \bar{x} = \frac{5a}{19} \quad (5)$$

\therefore centre of mass of the spoon lies at A distance $\frac{5a}{19}$ from OD .

65

$$\rightarrow F = P \quad (5)$$

$$\uparrow R = W \quad (5)$$

$$E \curvearrowright P \times 2a = W \times \frac{5}{19} a \quad (5)$$

$$\therefore P = \frac{5}{38} W.$$

$$\Rightarrow F = \frac{5}{38} W.$$

$$\frac{F}{R} = \frac{5}{38} \quad (5)$$

$$\therefore \frac{1}{7} > \frac{F}{R} \quad (5)$$

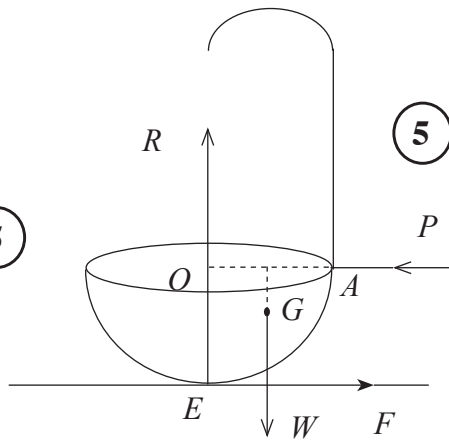

Hence, the spoon can be kept in equilibrium.

30

- 17.(a) Initially a box contains 3 balls identical in all aspects except for their colour, each of which is either white or black. Now, one white ball identical to balls in the box in all aspects except for its colour, is added into the box and then one ball is drawn at random from the box. Assuming that the four possible initial compositions of the balls in the box are equally likely, find the probability that
- (i) the ball drawn is white, and
 - (ii) initially there were exactly 2 black balls in the box, given that the ball drawn is white.
- (b) Let the mean and the standard deviation of the set of values $\{x_i : i = 1, 2, \dots, n\}$ be μ and σ respectively. Find the mean and the standard deviation of the set of values $\{\alpha x_i : i = 1, 2, \dots, n\}$, where α is a constant.

Monthly salaries of 50 employees at a certain company are summarised in the following table:

Monthly Salary (in thousand rupees)	Number of Employees
5 – 15	9
15 – 25	11
25 – 35	14
35 – 45	10
45 – 55	6

Estimate the mean and the standard deviation of the monthly salaries of the 50 employees.

At the beginning of a year, the monthly salary of each employee is increased by $p\%$. It is given that the mean of the new monthly salaries of the above 50 employees is 29 172 rupees. Estimate the value of p and the standard deviation of the new monthly salaries of the 50 employees.

- (a) Let E_i be the initial composition of the box with i number of white balls, for $i = 0, 1, 2, 3$.

Then $P(E_i) = \frac{1}{4}$ for $i = 0, 1, 2, 3$

Let W be the event that the ball drawn at random is white.

Then

$$\begin{aligned}
 \text{(i) } P(W) &= \sum_{i=0}^3 P(W | E_i) P(E_i) && \text{(10)} \\
 &= \frac{1}{4} \times \frac{1}{4} + \frac{2}{4} \times \frac{1}{4} + \frac{3}{4} \times \frac{1}{4} \times \frac{4}{4} \times \frac{1}{4} && \text{(10)} \\
 &= \frac{5}{8} && \text{(5)}
 \end{aligned}$$

25

- (ii) By Bayes theorem,

$$P(E_1 | W) = \frac{P(W | E_1) P(E_1)}{P(W)} \text{ (10)}$$

$$= \frac{\frac{2}{4} \times \frac{1}{4}}{\frac{5}{8}} \quad (10)$$

$$= \frac{1}{5} \quad (5)$$

25

(b) Let $Y = \{\alpha x_i : i = 1, 2, \dots, n\}$

mean : $\mu_y = \frac{\sum_{i=1}^n (\alpha x_i)}{n} = \alpha \left(\frac{\sum_{i=1}^n x_i}{n} \right) = \alpha \mu \quad (5) + (5)$

variance : $\sigma_y^2 = \frac{\sum_{i=1}^n (\alpha x_i)^2}{n} - \mu_y^2 \quad (5)$

$$= \alpha^2 \left[\frac{\sum_{i=1}^n x_i^2}{n} - \mu^2 \right] \quad (5)$$

$$= \alpha^2 \sigma^2 \quad (5)$$

\therefore The standard deviation $\sigma_y = |\alpha| \sigma \quad (5)$

30

Monthly salary (in thousand rupees)	f	Mid Point x	$y = \frac{1}{10}x$	y^2	fy	fy^2
5 - 15	9	10	1	1	9	9
15 - 25	11	20	2	4	22	44
25 - 35	14	30	3	9	42	126
35 - 45	10	40	4	16	40	160
45 - 55	6	50	5	25	30	150
	50				$\sum fx = 143$	$\sum fx^2 = 489$

$$\mu_y = \frac{\sum fy}{\sum f} = \frac{143}{50} \quad \text{and} \quad \sigma_y^2 = \frac{\sum fy^2}{\sum f} - \mu_y^2 = \frac{489}{50} - \left(\frac{143}{50} \right)^2 \quad (5)$$

(5)

$$\sigma_y = \frac{\sqrt{4001}}{50} \quad (5)$$

Using previous results :

$$\mu_x = 10\mu_y = 10 \left(\frac{143}{50} \right) = 28.6 \text{ thousand rupees } \textcircled{5}$$

$$(\text{= } 28600 \text{ rupees})$$

$$\text{and } \sigma_x = 10\sigma_y = \frac{\sqrt{4001}}{5} \approx 12.65 \text{ thousand rupees } \textcircled{5}$$

$$(\approx 12650 \text{ rupees})$$

50

New monthly salary : $z = x + \frac{p}{100} x = \left(1 + \frac{p}{100} \right) x$, where x is the previous monthly salary. $\textcircled{5}$

Using Previous results : $\mu_z = \left(1 + \frac{p}{100} \right) \mu_x$

$$29172 = \left(1 + \frac{p}{100} \right) 28600 \quad \textcircled{5}$$

$$\Rightarrow \frac{29172}{286} = 100 + p \quad \therefore p = 2 \quad \textcircled{5}$$

$$\sigma_z \approx \left(1 + \frac{2}{100} \right) \sigma_x$$

$$\approx \frac{51}{50} \times 12.65 \quad \textcircled{5}$$

≈ 12.9 thousand rupees

(≈ 12900 rupees)

20

G.C.E. (A.L.) Examination - 2019
10 - Combined Mathematics I
(New Syllabus)

Distribution of Marks

Paper I

$$\text{Part A : } 10 \times 25 = 250$$

$$\text{Part B : } 05 \times 150 = 750$$

$$\text{Total} = 1000 / 10$$

$$\text{Paper I Final Mark} = 100$$

Common Techniques of Marking Answer Scripts.

It is compulsory to adhere to the following standard method in marking answer scripts and entering marks into the mark sheets.

1. Use a red color ball point pen for marking. (Only Chief/Additional Chief Examiner may use a mauve color pen.)
2. Note down Examiner's Code Number and initials on the front page of each answer script.
3. Write off any numerals written wrong with a clear single line and authenticate the alterations with Examiner's initials.
4. Write down marks of each subsection in a \triangle and write the final marks of each question as a rational number in a \square with the question number. Use the column assigned for Examiners to write down marks.

Example: Question No. 03

(i)	✓	\triangle $\frac{4}{5}$
		
		
(ii)	✓	\triangle $\frac{3}{5}$
		
		
(iii)	✓	\triangle $\frac{3}{5}$
		
		

03	(i)	$\frac{4}{5}$	+	(ii)	$\frac{3}{5}$	+	(iii)	$\frac{3}{5}$	=	$\frac{10}{15}$
----	-----	---------------	---	------	---------------	---	-------	---------------	---	-----------------

MCQ answer scripts: (Template)

1. Marking templates for G.C.E.(A/L) and GIT examination will be provided by the Department of Examinations itself. Marking examiners bear the responsibility of using correctly prepared and certified templates.
2. Then, check the answer scripts carefully. If there are more than one or no answers Marked to a certain question write off the options with a line. Sometimes candidates may have erased an option marked previously and selected another option. In such occasions, if the erasure is not clear write off those options too.
3. Place the template on the answer script correctly. Mark the right answers with a 'v' and the wrong answers with a 'X' against the options column. Write down the number of correct answers inside the cage given under each column. Then, add those numbers and write the number of correct answers in the relevant cage.

Structured essay type and assay type answer scripts:

1. Cross off any pages left blank by candidates. Underline wrong or unsuitable answers. Show areas where marks can be offered with check marks.
2. Use the right margin of the overland paper to write down the marks.
3. Write down the marks given for each question against the question number in the relevant cage on the front page in two digits. Selection of questions should be in accordance with the instructions given in the question paper. Mark all answers and transfer the marks to the front page, and write off answers with lower marks if extra questions have been answered against instructions.
4. Add the total carefully and write in the relevant cage on the front page. Turn pages of answer script and add all the marks given for all answers again. Check whether that total tallies with the total marks written on the front page.

Preparation of Mark Sheets.

Except for the subjects with a single question paper, final marks of two papers will not be calculated within the evaluation board this time. Therefore, add separate mark sheets for each of the question paper. Write paper 01 marks in the paper 01 column of the mark sheet and write them in words too. Write paper II Marks in the paper II Column and wright the relevant details. For the subject 51 Art, marks for Papers 01, 02 and 03 should be entered numerically in the mark sheets.

1. Using the Principle of Mathematical Induction, prove that $\sum_{r=1}^n (2r-1) = n^2$ for all $n \in \mathbb{Z}^+$.

For $n = 1$, L.H.S. = $2 \times 1 - 1 = 1$ and R.H.S. = $1^2 = 1$ (5)

\therefore The result is true for $n = 1$.

Take any $p \in \mathbb{Z}^+$ and assume that the result is true for $n = p$.

$$\text{i.e. } \sum_{r=1}^p (2r-1) = p^2. \quad (5)$$

$$\text{Now } \sum_{r=1}^{p+1} (2r-1) = \sum_{r=1}^p (2r-1) + (2(p+1)-1) \quad (5)$$

$$= p^2 + (2p + 1)$$

$$= (p+1)^2. \quad (5)$$

Hence, if the result is true for $n = p$, then it is true for $n = p + 1$. We have already proved that the result is true for $n = 1$.

Hence, by the Principle of Mathematical Induction, the result is true for all $n \in \mathbb{Z}^+$. (5)

25

2. Sketch the graphs of $y=|4x-3|$ and $y=3-2|x|$ in the same diagram.
Hence or otherwise, find all real values of x satisfying the inequality $|2x-3|+|x|<3$.

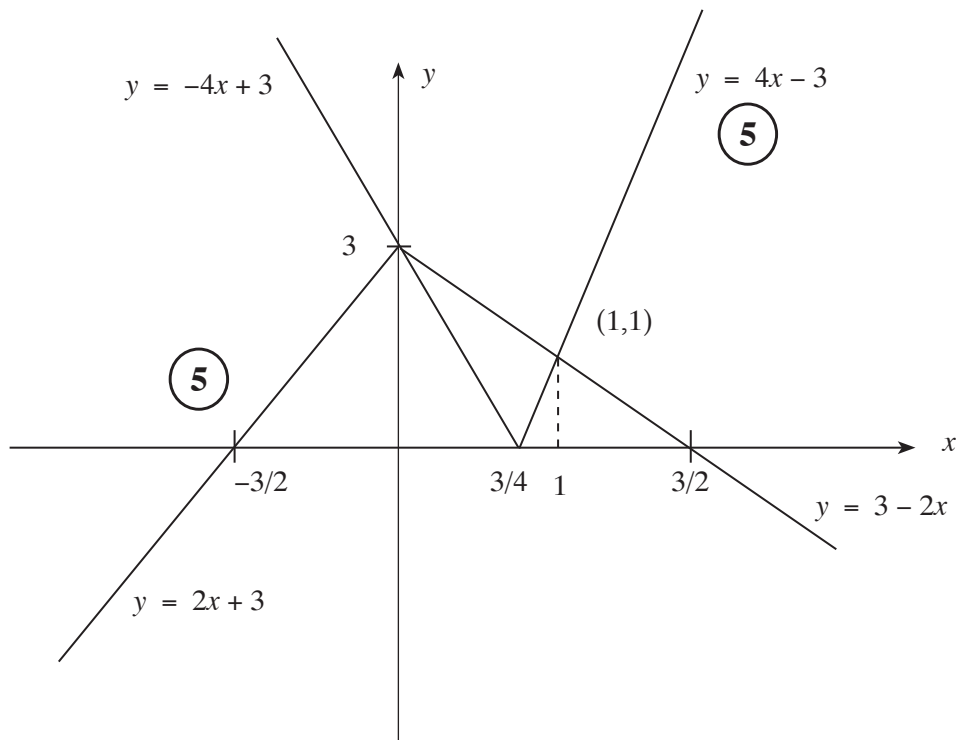

At the point of intersections of the graphs

$$4x - 3 = 3 - 2x \Rightarrow x = 1 \quad (5)$$

$$-4x + 3 = 3 + 2x \Rightarrow x = 0$$

From the graphs, we have,

$$|4x - 3| < 3 - 2|x| \Leftrightarrow 0 < x < 1$$

$$\therefore |4x - 3| + |2x| < 3 \Leftrightarrow 0 < x < 1$$

Replacing x by $\frac{x}{2}$, we get

$$|2x - 3| + |x| < 3 \Leftrightarrow 0 < x < 2. \quad (5)$$

Hence, the set of all values of x satisfying

$$|2x - 3| + |x| < 3 \text{ is } \{x : 0 < x < 2\}. \quad (5)$$

25

Aliter

For the graphs $\textcircled{5} + \textcircled{5}$, as before.

Aliter for values of x

$$|2x - 3| + |x| < 3$$

Case (i) $x \leq 0$:

$$\text{Then } |2x - 3| + |x| < 3 \Leftrightarrow -2x + 3 - x < 3$$

$$\Leftrightarrow 3x > 0$$

$$\Leftrightarrow x > 0$$

Hence, in this case, no solutions exist.

Case (ii) $0 < x \leq \frac{3}{2}$

$$\text{Then } |2x - 3| + |x| < 3 \Leftrightarrow -2x + 3 + x < 3$$

$$\Leftrightarrow x > 0$$

Hence, in this case, the solutions are the values of x satisfying $0 < x \leq \frac{3}{2}$.

Case (iii) $x > \frac{3}{2}$

$$\text{Then } |2x - 3| + |x| < 3 \Leftrightarrow 2x - 3 + x < 3$$

$$\Leftrightarrow 3x < 6$$

$$\Leftrightarrow x < 2$$

Hence, in this case, the solutions are the values of x satisfying $\frac{3}{2} < x < 2$.

All 3 cases with correct solutions $\textcircled{10}$

Any 2 cases with correct solutions $\textcircled{5}$

Hence, over all, the solutions are values of x satisfying $0 < x < 2$.

$\textcircled{5}$

25

3. Sketch, in an Argand diagram, the locus of the points that represent complex numbers z satisfying $\text{Arg}(z - 2 - 2i) = -\frac{3\pi}{4}$.
 Hence or otherwise, find the minimum value of $|i\bar{z} + 1|$ such that $\text{Arg}(z - 2 - 2i) = -\frac{3\pi}{4}$.

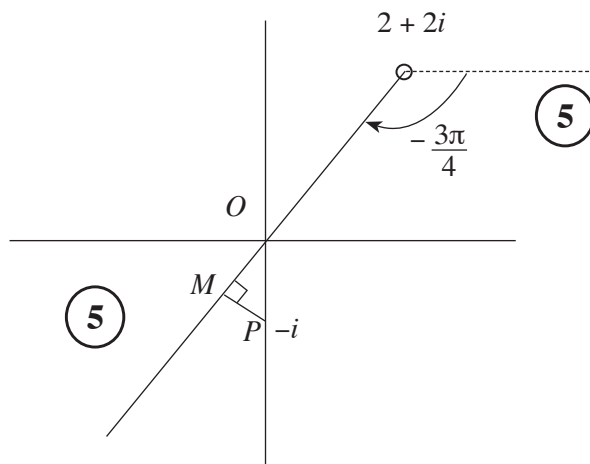

Note that

$$\begin{aligned}
 |i\bar{z} + 1| &= |i(\bar{z} - i)| = |\bar{z} - i| = |\overline{z + i}| \\
 &= |z + i| \\
 &= |z - (-i)| \quad \text{(5)}
 \end{aligned}$$

Hence, the minimum of $|i\bar{z} + 1|$ is equal to PM. (5)

Now, $PM = 1 \cdot \sin \frac{\pi}{4} = \frac{1}{\sqrt{2}}$. (5)

25

4. Show that the coefficient of x^6 in the binomial expansion of $\left(x^3 + \frac{1}{x^2}\right)^7$ is 35.

Show also that there **does not exist** a term independent of x in the above binomial expansion.

$$\left(x^3 + \frac{1}{x^2}\right)^7 = \sum_{r=0}^7 {}^7C_r (x^3)^r \left(\frac{1}{x^2}\right)^{7-r} \quad (5)$$

$$= \sum_{r=0}^7 {}^7C_r x^{5r-14}$$

$$x^6 : 5r - 14 = 6 \Leftrightarrow r = 4. \quad (5)$$

$$\therefore \text{The coefficient of } x^6 = {}^7C_4 = 35 \quad (5)$$

For the above expansion to have a term independent of x , we must have

$$5r - 14 = 0. \quad (5)$$

$$\text{This is not possible as } r \in \mathbb{Z}^+. \quad (5)$$

25

5. Show that $\lim_{x \rightarrow 3} \frac{\sqrt{x-2}-1}{\sin(\pi(x-3))} = \frac{1}{2\pi}$.

$$\lim_{x \rightarrow 3} \frac{\sqrt{x-2}-1}{\sin(\pi(x-3))} = \lim_{x \rightarrow 3} \frac{\sqrt{x-2}-1}{\sin(\pi(x-3))} \cdot \frac{(\sqrt{x-2}+1)}{(\sqrt{x-2}+1)} \quad (5)$$

$$= \lim_{x \rightarrow 3} \frac{x-3}{\sin(\pi(x-3))} \cdot \lim_{x \rightarrow 3} \frac{1}{(\sqrt{x-2}+1)} \quad (5)$$

$$= \lim_{x \rightarrow 3} \frac{1}{\frac{\sin(\pi(x-3))}{\pi(x-3)}} \cdot \frac{1}{\pi} \cdot \frac{1}{2} \quad (5)$$

$$= 1 \cdot \frac{1}{\pi} \cdot \frac{1}{2} \quad (5)$$

$$= \frac{1}{2\pi} \quad (5)$$

25

6. The region enclosed by the curves $y = \sqrt{\frac{x+1}{x^2+1}}$, $x=0$, $x=1$ and $y=0$ is rotated about the x -axis through 2π radians. Show that the volume of the solid thus generated is $\frac{\pi}{4}(\pi + \ln 4)$.

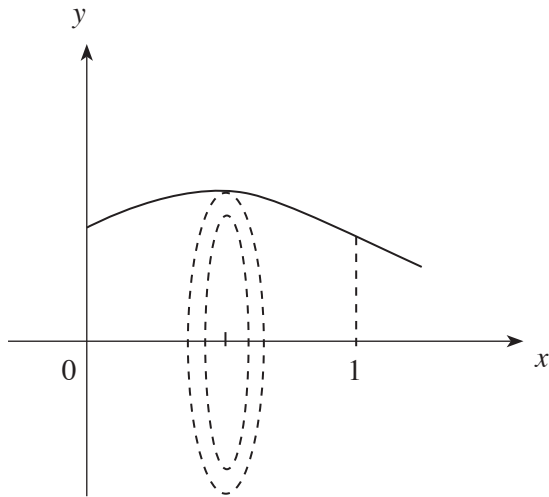

$$\begin{aligned}
 \text{The volume generated} &= \int_0^1 \pi \left(\sqrt{\frac{x+1}{x^2+1}} \right)^2 dx \quad (5) \\
 &= \pi \left(\int_0^1 \frac{x}{x^2+1} dx + \int_0^1 \frac{1}{x^2+1} dx \right) \quad (5) \\
 &= \pi \left(\frac{1}{2} \ln(x^2+1) \Big|_0^1 + \tan^{-1} x \Big|_0^1 \right) \quad (5) + \quad (5) \\
 &= \pi \left(\frac{1}{2} \ln 2 + \frac{\pi}{4} \right) \\
 &= \frac{\pi}{4} (\ln 4 + \pi) \quad (5)
 \end{aligned}$$

25

7. Let C be the parabola parametrically given by $x = at^2$ and $y = 2at$ for $t \in \mathbb{R}$, where $a \neq 0$. Show that the equation of the normal line to the parabola C at the point $(at^2, 2at)$ is given by $y + tx = 2at + at^3$.

The normal line at the point $P \equiv (4a, 4a)$ on the parabola C meets this parabola again at a point $Q \equiv (aT^2, 2aT)$. Show that $T = -3$.

$$x = at^2, \quad y = 2at$$

$$\frac{dx}{dt} = 2at, \quad \frac{dy}{dt} = 2a$$

$$\frac{dy}{dx} = \frac{dy}{dt} \cdot \frac{dt}{dx} = 2a \cdot \frac{1}{2at} = \frac{1}{t} \quad \text{for } t \neq 0. \quad (5)$$

\therefore The slope of the normal line = $-t$

The equation of the normal at $(at^2, 2at)$ is

$$y - 2at = -t(x - at^2)$$

$$y + tx = 2at + at^3 \quad (5) \quad (\text{This is valid for } t = 0 \text{ also.})$$

$$P \equiv (4a, 4a) \text{ on } C \Rightarrow t = 2.$$

$$\text{The normal line at } P : y + 2x = 4a + 8a = 12a \quad (5)$$

Since it meets C at $(aT^2, 2aT)$, we have

$$2aT + 2aT^2 = 12a. \quad (5)$$

$$\Leftrightarrow T^2 + T - 6 = 0 \Leftrightarrow (T - 2)(T + 3) = 0$$

$$\Leftrightarrow T = 2 \quad \text{or} \quad T = -3$$

$$\therefore T = -3 \quad (5)$$

25

8. Let l_1 and l_2 be the straight lines given by $x + y = 4$ and $4x + 3y = 10$, respectively. Two distinct points P and Q are on the line l_1 such that the perpendicular distance from each of these points to the line l_2 is 1 unit. Find the coordinates of P and Q .

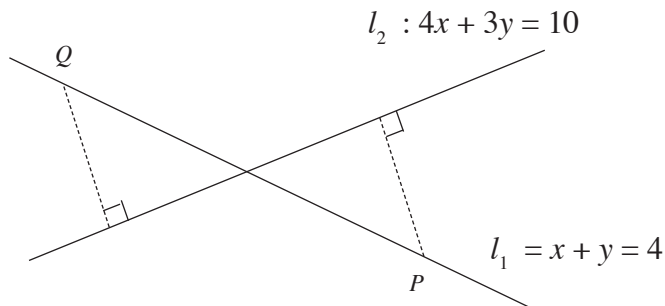

Any point on the line l_1 can be written in the form

$$(t, 4 - t), t \in \mathbb{R}. \quad (5)$$

Let $P \equiv (t_1, 4 - t_1)$

$$\text{Perpendicular distance from } P \text{ to } l_2 = \frac{|4t_1 + 3(4 - t_1) - 10|}{\sqrt{4^2 + 3^2}} = 1$$

$$\therefore |t_1 + 2| = 5 \quad (5)$$

$$\therefore t_1 = -7 \text{ or } t_1 = 3 \quad (5)$$

The coordinates of P and Q are

$$(-7, 11) \text{ and } (3, 1). \quad (5) + (5)$$

25

9. Show that the point $A \equiv (-7, 9)$ lies outside the circle $S \equiv x^2 + y^2 - 4x + 6y - 12 = 0$.
Find the coordinates of the point on the circle $S=0$ nearest to the point A .

The centre C of $S = 0$ is $(2, -3)$. (5)

The radius R of $S = 0$ is $\sqrt{4+9+12} = \sqrt{25} = 5$. (5)

$CA^2 = 9^2 + 12^2 = 15^2 \Rightarrow CA = 15 > R = 5$. (5)

\therefore Point A lies outside the given circle.

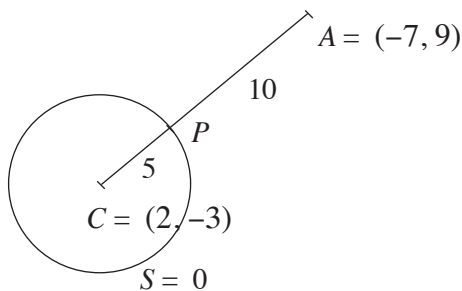

The point on the circle $S = 0$ nearest to point A is the point P at which CA meets $S = 0$.

Note that $CP : PA = 5 : 10 = 1 : 2$ (5)

$$\therefore P \equiv \left(\frac{2 \times 2 + 1(-7)}{3}, \frac{2(-3) + 1 \times 9}{3} \right)$$

i.e. $P \equiv (-1, 1)$ (5)

25

10. Let $t = \tan \frac{\theta}{2}$ for $\theta \neq (2n+1)\pi$, where $n \in \mathbb{Z}$. Show that $\cos \theta = \frac{1-t^2}{1+t^2}$.

Deduce that $\tan \frac{\pi}{12} = 2 - \sqrt{3}$.

$$\cos \theta = \cos^2 \frac{\theta}{2} - \sin^2 \frac{\theta}{2} \quad (5)$$

$$= \frac{\cos^2 \frac{\theta}{2} - \sin^2 \frac{\theta}{2}}{\cos^2 \frac{\theta}{2} + \sin^2 \frac{\theta}{2}} = \frac{1 - \tan^2 \frac{\theta}{2}}{1 + \tan^2 \frac{\theta}{2}} \quad \text{for } \theta \neq (2n+1)\pi. \quad (5)$$

$$= \frac{1-t^2}{1+t^2}$$

Let $\theta = \frac{\pi}{6}$. Then $\frac{\sqrt{3}}{2} = \frac{1-t^2}{1+t^2}$

(5)

$$\Rightarrow \sqrt{3}(1+t^2) = 2(1-t^2)$$

$$(2 + \sqrt{3})t^2 = 2 - \sqrt{3}$$

$$\therefore t^2 = \frac{(2 - \sqrt{3})}{(2 + \sqrt{3})} \quad (5)$$

$$= (2 - \sqrt{3})^2$$

$$\Rightarrow t = \tan \frac{\pi}{12} = 2 - \sqrt{3} \quad (5) \quad \left(\because \tan \frac{\pi}{12} > 0 \right)$$

25

11. (a) Let $p \in \mathbb{R}$ and $0 < p \leq 1$. Show that 1 is **not** a root of the equation $p^2x^2 + 2x + p = 0$.
 Let α and β be the roots of this equation. Show that α and β are both real.
 Write down $\alpha + \beta$ and $\alpha\beta$ in terms of p , and show that

$$\frac{1}{(\alpha - 1)} \cdot \frac{1}{(\beta - 1)} = \frac{p^2}{p^2 + p + 2}.$$

Show also that the quadratic equation whose roots are $\frac{\alpha}{\alpha - 1}$ and $\frac{\beta}{\beta - 1}$ is given by $(p^2 + p + 2)x^2 - 2(p + 1)x + p = 0$ and that both of these roots are positive.

- (b) Let c and d be two **non-zero** real numbers and let $f(x) = x^3 + 2x^2 - dx + cd$. It is given that $(x - c)$ is a factor of $f(x)$ and that the remainder when $f(x)$ is divided by $(x - d)$ is cd . Find the values of c and d .

For these values of c and d , find the remainder when $f(x)$ is divided by $(x + 2)^2$.

- (a) Suppose that 1 is a root of $p^2x^2 + 2x + p = 0$.

By substituting $x = 1$, we must have $p^2 + 2 + p = 0$. (5)

This is impossible, as $p > 0$ implies that $p^2 + 2 + p > 0$. (5)

\therefore 1 is not a root of $p^2x^2 + 2x + p = 0$

10

The discriminant $\Delta = 2^2 - 4p^2 \cdot p$ (10)

$$= 4(1 - p^3)$$

$$\geq 0 \quad (\because 0 < p \leq 1) \quad (5)$$

\therefore α and β are both real. (5)

20

$$\alpha + \beta = -\frac{2}{p^2} \quad \text{and} \quad \alpha\beta = \frac{1}{p} \quad (5) + (5)$$

Now,

$$\frac{1}{(\alpha - 1)} \cdot \frac{1}{(\beta - 1)} = \frac{1}{(\alpha\beta - (\alpha + \beta) + 1)} \quad (5)$$

$$= \frac{1}{\frac{1}{p} + \frac{2}{p^2} + 1}$$

$$= \frac{p^2}{p^2 + p + 2} \quad (5)$$

20

Now

$$\begin{aligned} \frac{\alpha}{\alpha-1} + \frac{\beta}{\beta-1} &= \frac{\alpha(\beta-1) + \beta(\alpha-1)}{(\alpha-1)(\beta-1)} \\ &= \frac{2\alpha\beta - (\alpha + \beta)}{(\alpha-1)(\beta-1)} \quad (5) \\ &= \left(\frac{2}{p} + \frac{2}{p^2}\right) \cdot \frac{p^2}{p^2 + p + 2} \quad (5) \\ &= \frac{2(p+1)}{p^2} \cdot \frac{p^2}{p^2 + p + 2} \\ &= \frac{2(p+1)}{p^2 + p + 2} \quad (5) \end{aligned}$$

and

$$\begin{aligned} \frac{\alpha}{\alpha-1} \cdot \frac{\beta}{\beta-1} &= \frac{\alpha\beta}{(\alpha-1)(\beta-1)} \\ &= \frac{1}{p} \cdot \frac{p^2}{p^2 + p + 2} \\ &= \frac{p}{p^2 + p + 2} \cdot (5) \end{aligned}$$

Hence, the required quadratic equation is given by

$$\begin{aligned} x^2 - \frac{2(p+1)}{p^2 + p + 2} x + \frac{p}{p^2 + p + 2} &= 0 \quad (10) \\ \Rightarrow (p^2 + p + 2)x^2 - 2(p+1)x + p &= 0 \quad (5) \end{aligned}$$

35

Moreover, note that $\frac{\alpha}{(\alpha-1)}$ and $\frac{\beta}{(\beta-1)}$ are both real,

$$\frac{\alpha}{(\alpha-1)} + \frac{\beta}{(\beta-1)} = \frac{2(p+1)}{p^2 + p + 2} > 0, \quad (\because p > 0), \quad (5)$$

$$\text{and } \frac{\alpha}{(\alpha-1)} \cdot \frac{\beta}{(\beta-1)} = \frac{p}{p^2 + p + 2} > 0, \quad (\because p > 0).$$

Hence, both of these roots are positive. (5)

10

$$(b) \quad f(x) = x^3 + 2x^2 - dx + cd$$

$$\text{Since } (x - c) \text{ is a factor, } f(c) = 0. \quad (5)$$

$$\Rightarrow c^3 + 2c^2 - dc + cd = 0 \quad (5)$$

$$\Rightarrow c^2(c + 2) = 0$$

$$\Rightarrow c = -2 \quad (\because c \neq 0) \quad (5)$$

Since, when $f(x)$ is divided by $(x - d)$, the remainder is cd , we have

$$f(d) = cd. \quad (5)$$

$$\Rightarrow d^3 + 2d^2 - d^2 + cd = cd \quad (5)$$

$$\Rightarrow d^3 + d^2 = 0$$

$$\Rightarrow d^2(d + 1) = 0$$

$$\Rightarrow d = -1 \quad (\because d \neq 0) \quad (5)$$

$$\therefore c = -2 \text{ and } d = -1.$$

30

$$f(x) = x^3 + 2x^2 + x + 2.$$

Let $Ax + B$ be the remainder, when $f(x)$ is divided by $(x + 2)^2$.

Then $f(x) \equiv (x + 2)^2 Q(x) + (Ax + B)$, where $Q(x)$ is a polynomial of degree 1.

$$\text{So, } x^3 + 2x^2 + x + 2 \equiv (x + 2)^2 Q(x) + Ax + B. \quad (5)$$

$$\text{Substituting } x = -2, \text{ we obtain } 0 = -2A + B. \quad (5)$$

By differentiating, we have

$$3x^2 + 4x + 1 = (x + 2)^2 Q'(x) + 2Q(x)(x + 2) + A. \quad (5)$$

Again by substituting $x = -2$, we obtain

$$12 - 8 + 1 = A \quad (5)$$

$$\therefore A = 5 \text{ and } B = 10$$

$$\text{Hence the remainder is } 5x + 10. \quad (5)$$

25

Aliter

By long division we have,

$$\begin{array}{r}
 x^2 + 4x + 4 \quad \overline{) \quad \begin{array}{l} x^3 + 2x^2 + x + 2 \\ x^3 + 4x^2 + 4x \\ \hline -2x^2 - 3x + 2 \\ -2x^2 - 8x - 8 \\ \hline 5x + 10. \end{array} \\
 \end{array}$$

15

$$x^3 + 2x^2 + x + 2 \equiv (x^2 + 4x + 4)(x - 2) + (5x + 10)$$

∴ Required remainder is $5x + 10$.**10****25**

12. (a) Let P_1 and P_2 be the two sets given by $\{A, B, C, D, E, 1, 2, 3, 4\}$ and $\{F, G, H, I, J, 5, 6, 7, 8\}$ respectively. It is required to form a password consisting of 6 elements taken from $P_1 \cup P_2$ of which 3 are different letters and 3 are different digits. In each of the following cases, find the number of different such passwords that can be formed:

- (i) all 6 elements are chosen only from P_1 ,
- (ii) 3 elements are chosen from P_1 and the other 3 elements from P_2 .

(b) Let $U_r = \frac{1}{r(r+1)(r+3)(r+4)}$ and $V_r = \frac{1}{r(r+1)(r+2)}$ for $r \in \mathbb{Z}^+$.

Show that $V_r - V_{r+2} = 6U_r$ for $r \in \mathbb{Z}^+$.

Hence, show that $\sum_{r=1}^n U_r = \frac{5}{144} - \frac{(2n+5)}{6(n+1)(n+2)(n+3)(n+4)}$ for $n \in \mathbb{Z}^+$.

Let $W_r = U_{2r-1} + U_{2r}$ for $r \in \mathbb{Z}^+$.

Deduce that $\sum_{r=1}^n W_r = \frac{5}{144} - \frac{(4n+5)}{24(n+1)(n+2)(2n+1)(2n+3)}$ for $n \in \mathbb{Z}^+$.

Hence, show that the infinite series $\sum_{r=1}^{\infty} W_r$ is convergent and find its sum.

(a) $P_1 = \{A, B, C, D, E, 1, 2, 3, 4\}$ and $P_2 = \{F, G, H, I, J, 5, 6, 7, 8\}$

(i) The number of different ways of choosing 3 different letters and 3 different

digits from $P_1 = {}^5C_3 \cdot {}^4C_3$ (10)

Hence the number of passwords that can be formed by choosing all 6 elements from P_1

$= {}^5C_3 \cdot {}^4C_3 \cdot 6!$ (5)

$= 28800$ (5)

20

(ii)

Different ways of selecting				Number of Passwords
from P_1		from P_2		
Letters	Digits	Letters	Digits	
3	–	–	3	${}^5C_3 \cdot {}^4C_3 \cdot 6! = 28800$
2	1	1	2	${}^5C_2 \cdot {}^4C_1 \cdot {}^5C_1 \cdot {}^4C_2 \cdot 6! = 864000$
1	2	2	1	${}^5C_1 \cdot {}^4C_2 \cdot {}^5C_2 \cdot {}^4C_1 \cdot 6! = 864000$
–	3	3	–	${}^4C_3 \cdot {}^5C_3 \cdot 6! = 28800$

(10)

(10)

(10)

(10)

Hence, the number of different passwords that can be formed by choosing 3 elements

from P_1 and the other 3 elements from $P_2 = 28800 + 864000 + 864000 + 28800 = 1785600$

10

50

(b) $U_r = \frac{1}{r(r+1)(r+3)(r+4)}$ and $V_r = \frac{1}{r(r+1)(r+2)}$; $r \in \mathbb{Z}^+$.

Then,

$$V_r - V_{r+2} = \frac{1}{r(r+1)(r+2)} - \frac{1}{(r+2)(r+3)(r+4)} \quad (5)$$

$$= \frac{(r+3)(r+4) - r(r+1)}{r(r+1)(r+2)(r+3)(r+4)}$$

$$= \frac{6(r+2)}{r(r+1)(r+2)(r+3)(r+4)} \quad (5)$$

$$= 6U_r \quad (5)$$

15

Now note that,

$$\begin{aligned} r = 1; & \quad 6U_1 = V_1 - \cancel{V_3}, \\ r = 2; & \quad 6U_2 = V_2 - \cancel{V_4}, \\ r = 3; & \quad 6U_3 = \cancel{V_3} - V_5, \\ r = 4; & \quad 6U_4 = \cancel{V_4} - V_6, \end{aligned} \quad (10)$$

⋮ ⋮ ⋮

$$\begin{aligned} r = n-3; & \quad 6U_{n-3} = V_{n-3} - \cancel{V_{n-1}}, \\ r = n-2; & \quad 6U_{n-2} = V_{n-2} - \cancel{V_n}, \\ r = n-1; & \quad 6U_{n-1} = \cancel{V_{n-1}} - V_{n+1}, \\ r = n; & \quad 6U_n = \cancel{V_n} - V_{n+2} \end{aligned} \quad (10)$$

$$\begin{aligned} \therefore 6 \sum_{r=1}^n U_r &= V_1 + V_2 - V_{n+1} - V_{n+2} \quad (10) \\ &= \frac{1}{6} + \frac{1}{24} - \frac{1}{(n+1)(n+2)(n+3)} - \frac{1}{(n+2)(n+3)(n+4)} \quad (5) \\ &= \frac{5}{24} - \frac{2n+5}{(n+1)(n+2)(n+3)(n+4)} \\ \therefore \sum_{r=1}^n U_r &= \frac{5}{144} - \frac{2n+5}{6(n+1)(n+2)(n+3)(n+4)} \quad (5) \end{aligned}$$

40

$$W_r = U_{2r-1} + U_{2r}, \quad r \in \mathbb{Z}^+.$$

$$\begin{aligned} \therefore \sum_{r=1}^n W_r &= \sum_{r=1}^n (U_{2r-1} + U_{2r}) \\ &= \sum_{r=1}^{2n} U_r \quad (5) \\ &= \frac{5}{144} - \frac{4n+5}{6(2n+1)(2n+2)(2n+3)(2n+4)} \\ \therefore \sum_{r=1}^n W_r &= \frac{5}{144} - \frac{4n+5}{24(n+1)(n+2)(2n+1)(2n+3)} \quad (5) \end{aligned}$$

10

Note that,

$$\begin{aligned} \lim_{n \rightarrow \infty} \sum_{r=1}^n W_r &= \lim_{n \rightarrow \infty} \left(\frac{5}{144} - \frac{4n+5}{24(n+1)(n+2)(2n+1)(2n+3)} \right) \quad (5) \\ &= \frac{5}{144} - \lim_{n \rightarrow \infty} \frac{4n+5}{24(n+1)(n+2)(2n+1)(2n+3)} \\ &= \frac{5}{144} \quad (5) \end{aligned}$$

$$\therefore \sum_{r=1}^{\infty} W_r \text{ is convergent and the sum is } \frac{5}{144}. \quad (5)$$

15

13. (a) Let $A = \begin{pmatrix} a & 0 & -1 \\ 0 & -1 & 0 \end{pmatrix}$, $B = \begin{pmatrix} 2 & 1 & 3 \\ 1 & -a & 4 \end{pmatrix}$ and $C = \begin{pmatrix} b & -2 \\ -1 & b+1 \end{pmatrix}$ be matrices such that

$AB^T = C$, where $a, b \in \mathbb{R}$.

Show that $a = 2$ and $b = 1$.

Show also that, C^{-1} does not exist.

Let $P = \frac{1}{2}(C - 2I)$. Write down P^{-1} and find the matrix Q such that $2P(Q + 3I) = P - I$, where I is the identity matrix of order 2.

(b) Let $z, z_1, z_2 \in \mathbb{C}$.

Show that (i) $\operatorname{Re} z \leq |z|$, and

$$(ii) \frac{|z_1|}{|z_2|} = \frac{|z_1|}{|z_2|} \text{ for } z_2 \neq 0.$$

Deduce that $\operatorname{Re} \left(\frac{z_1}{z_1 + z_2} \right) \leq \frac{|z_1|}{|z_1 + z_2|}$ for $z_1 + z_2 \neq 0$.

Verify that $\operatorname{Re} \left(\frac{z_1}{z_1 + z_2} \right) + \operatorname{Re} \left(\frac{z_2}{z_1 + z_2} \right) = 1$ for $z_1 + z_2 \neq 0$,

and show that $|z_1 + z_2| \leq |z_1| + |z_2|$ for $z_1, z_2 \in \mathbb{C}$.

(c) Let $\omega = \frac{1}{2}(1 - \sqrt{3}i)$.

Express $1 + \omega$ in the form $r(\cos \theta + i \sin \theta)$; where $r (> 0)$ and $\theta \left(-\frac{\pi}{2} < \theta < \frac{\pi}{2} \right)$ are constants to be determined.

Using De Moivre's theorem, show that $(1 + \omega)^{10} + (1 + \bar{\omega})^{10} = 243$.

$$(a) \quad AB^T = \begin{pmatrix} a & 0 & -1 \\ 0 & -1 & 0 \end{pmatrix} \begin{pmatrix} 2 & 1 \\ 1 & -a \\ 3 & 4 \end{pmatrix} = \begin{pmatrix} 2a-3 & a-4 \\ -1 & a \end{pmatrix}$$

(5)

(10)

$$AB^T = C \Leftrightarrow \begin{pmatrix} 2a-3 & a-4 \\ -1 & a \end{pmatrix} = \begin{pmatrix} b & -2 \\ -1 & b+1 \end{pmatrix}$$

$$\Leftrightarrow 2a - 3 = b, \quad a - 4 = -2 \text{ and } a = b + 1. \quad (10)$$

$\Leftrightarrow a = 2$ and $b = 1$, (from any two equations above) and these values satisfy the remaining equation.

(5)

30

$$C = \begin{pmatrix} 1 & -2 \\ -1 & 2 \end{pmatrix}$$

$$\begin{vmatrix} 1 & -2 \\ -1 & 2 \end{vmatrix} = 0 \quad (5)$$

$\therefore C^{-1}$ does not exist. (5)

10

Aliter

For the existence of C^{-1} :

there must exist $p, q, r, s \in \mathbb{R}$ such that

$$\begin{pmatrix} 1 & -2 \\ -1 & 2 \end{pmatrix} \begin{pmatrix} p & q \\ r & s \end{pmatrix} = \begin{pmatrix} 1 & 0 \\ 0 & 1 \end{pmatrix} \quad (5)$$

$$\Rightarrow p - 2r = 1, -p + 2r = 0, q - 2s = 0 \text{ and } -q + 2s = 1$$

This is a contradiction

$\therefore C^{-1}$ does not exist. (5)

10

$$P = \frac{1}{2} (C - 2I) = \frac{1}{2} \left\{ \begin{pmatrix} 1 & -2 \\ -1 & 2 \end{pmatrix} - \begin{pmatrix} 2 & 0 \\ 0 & 2 \end{pmatrix} \right\} = \frac{1}{2} \begin{pmatrix} -1 & -2 \\ -1 & 0 \end{pmatrix} \quad (5)$$

$$\Rightarrow P^{-1} = 2 \begin{pmatrix} 1 & \\ -2 & \end{pmatrix} \begin{pmatrix} 0 & 2 \\ 1 & -1 \end{pmatrix} = \begin{pmatrix} 0 & -2 \\ -1 & 1 \end{pmatrix} \quad (10)$$

$$2P(Q + 3I) = P - I$$

$$\Leftrightarrow 2(Q + 3I) = I - P^{-1} \quad (5)$$

$$\therefore 2(Q + 3I) = \begin{pmatrix} 1 & 2 \\ 1 & 0 \end{pmatrix} \quad (5)$$

$$\Rightarrow Q = \frac{1}{2} \begin{pmatrix} 1 & 2 \\ 1 & 0 \end{pmatrix} - 3I$$

$$= \begin{pmatrix} -\frac{5}{2} & 1 \\ \frac{1}{2} & -3 \end{pmatrix} \quad (5)$$

30

(b) $z, z_1, z_2 \in \mathbb{C}$.

(i) Let $z = x + iy, x, y \in \mathbb{R}$.

$$\operatorname{Re} z = x \leq \sqrt{x^2 + y^2} = |z| \quad (5)$$

(ii) Let $z_1 = r_1(\cos \theta_1 + i \sin \theta_1)$ and $z_2 = r_2(\cos \theta_2 + i \sin \theta_2)$.

$$\Rightarrow \frac{z_1}{z_2} = \frac{r_1(\cos \theta_1 + i \sin \theta_1) \times (\cos \theta_2 - i \sin \theta_2)}{r_2(\cos \theta_2 + i \sin \theta_2) \times (\cos \theta_2 - i \sin \theta_2)} = \frac{r_1}{r_2} \frac{[\cos(\theta_1 - \theta_2) + i \sin(\theta_1 - \theta_2)]}{1} \quad (5)$$

$$\therefore \left| \frac{z_1}{z_2} \right| = \frac{r_1}{r_2} = \frac{|z_1|}{|z_2|} \quad (5)$$

20

$$\operatorname{Re} \left(\frac{z_1}{z_1 + z_2} \right) \leq \left| \frac{z_1}{z_1 + z_2} \right| = \frac{|z_1|}{|z_1 + z_2|} \quad ; \text{ for } z_1 + z_2 \neq 0.$$

(5) by (i)
(5) by (ii)

10

For $z_1 + z_2 \neq 0$, we have

$$\frac{z_1}{z_1 + z_2} + \frac{z_2}{z_1 + z_2} = 1 \quad (5)$$

$$\operatorname{Re} \left(\frac{z_1}{z_1 + z_2} + \frac{z_2}{z_1 + z_2} \right) = 1$$

$$\operatorname{Re} \left(\frac{z_1}{z_1 + z_2} \right) + \operatorname{Re} \left(\frac{z_2}{z_1 + z_2} \right) = 1 \quad (5)$$

10

$$\begin{aligned} \Rightarrow 1 = \operatorname{Re}\left(\frac{z_1}{z_1 + z_2}\right) + \operatorname{Re}\left(\frac{z_2}{z_1 + z_2}\right) &\leq \left|\frac{z_1}{z_1 + z_2}\right| + \left|\frac{z_2}{z_1 + z_2}\right| \text{ by (i) } \textcircled{5} \\ &= \frac{|z_1|}{|z_1 + z_2|} + \frac{|z_2|}{|z_1 + z_2|} \text{ by (ii)} \\ &= \frac{|z_1| + |z_2|}{|z_1 + z_2|} \textcircled{5} \end{aligned}$$

$$\Rightarrow |z_1 + z_2| \leq |z_1| + |z_2| \quad (\because |z_1 + z_2| > 0)$$

Now if $z_1 + z_2 = 0$, then

$$|z_1 + z_2| = 0 \leq |z_1| + |z_2|$$

Hence, the result is true for all $z_1, z_2 \in \mathbb{C}$.

10

(c) $\omega = \frac{1}{2}(1 - \sqrt{3}i)$

$$1 + \omega = \sqrt{3} \left[\frac{\sqrt{3}}{2} + i \left(-\frac{1}{2} \right) \right] = r(\cos \theta + i \sin \theta), \textcircled{5}$$

where $r = \sqrt{3}$ and $\theta = -\frac{\pi}{6}$. $\textcircled{5}$

10

$$(1 + \omega)^{10} = (\sqrt{3})^{10} \left[\cos(10\theta) + i \sin(10\theta) \right] \text{ by De Moivre's theorem } \textcircled{5}$$

$$1 + \bar{\omega} = \overline{1 + \omega} = \sqrt{3} (\cos \theta - i \sin \theta) = \sqrt{3} \left[\cos(-\theta) + i \sin(-\theta) \right]$$

$$\Rightarrow (1 + \bar{\omega})^{10} = (\sqrt{3})^{10} \left[\cos(-10\theta) + i \sin(-10\theta) \right] \textcircled{5}$$

$$\therefore (1 + \omega)^{10} + (1 + \bar{\omega})^{10} = (\sqrt{3})^{10} \times 2 \cos(10\theta) \textcircled{5}$$

$$\begin{aligned} &= 3^5 \times 2 \times \frac{1}{2} \\ &= 243. \textcircled{5} \end{aligned}$$

20

14.(a) Let $f(x) = \frac{9(x^2 - 4x - 1)}{(x - 3)^3}$ for $x \neq 3$.

Show that $f'(x)$, the derivative of $f(x)$, is given by $f'(x) = -\frac{9(x+3)(x-5)}{(x-3)^4}$ for $x \neq 3$.

Sketch the graph of $y=f(x)$ indicating the asymptotes, y-intercept and the turning points.

It is given that $f''(x) = \frac{18(x^2 - 33)}{(x-3)^5}$ for $x \neq 3$.

Find the x -coordinates of the points of inflection of the graph of $y=f(x)$.

(b) The adjoining figure shows a basin in the form of a frustum of a right circular cone with a bottom. The slant length of the basin is 30 cm and the radius of the upper circular edge is twice the radius of the bottom. Let the radius of the bottom be r cm.

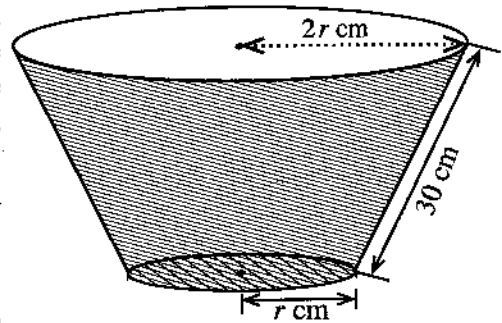

Show that the volume V cm³ of the basin is given by

$$V = \frac{7}{3} \pi r^2 \sqrt{900 - r^2} \text{ for } 0 < r < 30.$$

Find the value of r such that volume of the basin is maximum.

(a) For $x \neq 3$; $f(x) = \frac{9(x^2 - 4x - 1)}{(x - 3)^3}$

Then

$$f'(x) = 9 \left[\frac{1}{(x-3)^3} (2x-4) - \frac{3(x^2-4x-1)}{(x-3)^4} \right] \quad (20)$$

$$= 9 \left[\frac{2x^2 - 10x + 12 - 3(x^2 - 4x - 1)}{(x-3)^4} \right]$$

$$= -\frac{9(x+3)(x-5)}{(x-3)^4} \text{ for } x \neq 3 \quad (5)$$

25

Horizontal asymptotes : $\lim_{x \rightarrow \pm \infty} f(x) = 0 \quad \therefore y = 0. \quad (5)$

$$\lim_{x \rightarrow 3^-} f(x) = \infty \text{ and } \lim_{x \rightarrow 3^+} f(x) = -\infty.$$

Vertical asymptote : $x = 3. \quad (5)$

At the turning points $f'(x) = 0. \Leftrightarrow x = -3$ or $x = 5. \quad (5)$

	$-\infty < x < -3$	$-3 < x < 3$	$3 < x < 5$	$5 < x < \infty$
sign of $f'(x)$	(-)	(+)	(+)	(-)

$f(x)$ is (5) (5) (5) (5)

There are two turning points: $(-3, -\frac{5}{6})$ is a local minimum and $(5, \frac{9}{2})$ is a local maximum. (5) (5)

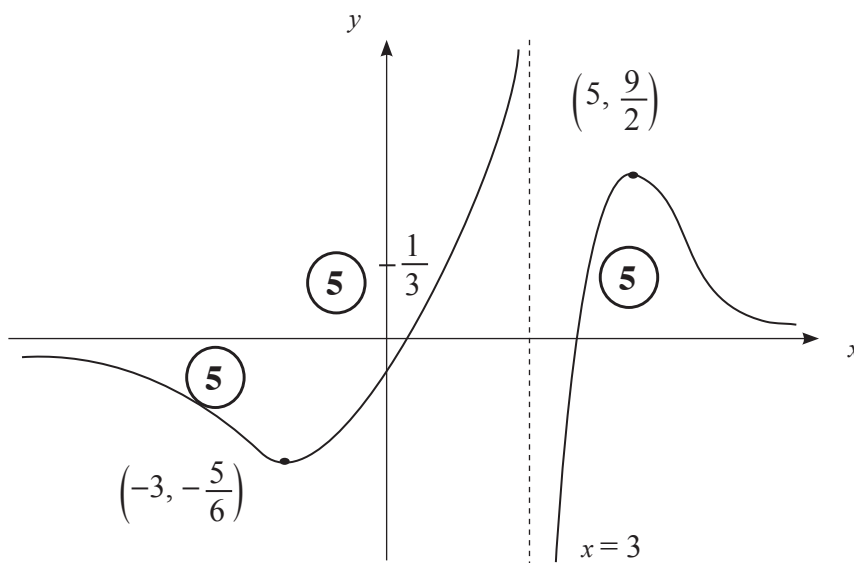

60

For $x \neq 3$;

$$f''(x) = \frac{18(x - \sqrt{33})(x + \sqrt{33})}{(x - 3)^5}$$

$$f''(x) = 0 \Leftrightarrow x = \pm \sqrt{33} \quad (5)$$

	$-\infty < x < -\sqrt{33}$	$-\sqrt{33} < x < 3$	$3 < x < \sqrt{33}$	$\sqrt{33} < x < \infty$
sign of $f''(x)$	(-)	(+)	(-)	(+)
concavity	concave down	concave up	concave down	concave up

10

\therefore There are two inflection points:

$x = -\sqrt{33}$ and $x = \sqrt{33}$ are the x - coordinates of the points of inflection. (5) 20

(b)

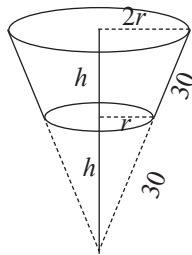

For $0 < r < 30$;

$$h = \sqrt{900 - r^2} \quad (5)$$

The volume V is given by

$$V = \frac{1}{3} \pi (2r)^2 \times 2h - \frac{1}{3} \pi r^2 h \quad (5)$$

$$= \frac{7}{3} \pi r^2 h$$

$$= \frac{7}{3} \pi r^2 \sqrt{900 - r^2} \quad (5)$$

15

For $0 < r < 30$,

$$\frac{dV}{dr} = \frac{7}{3} \pi \left[2r \sqrt{900 - r^2} + r^2 \frac{(-2r)}{2\sqrt{900 - r^2}} \right] \quad (5)$$

$$= \frac{7}{3} \pi \left[\frac{2r(900 - r^2) - r^3}{\sqrt{900 - r^2}} \right]$$

$$= 7\pi r \frac{(600 - r^2)}{\sqrt{900 - r^2}} \quad (5)$$

$$\frac{dV}{dr} = 0 \Leftrightarrow r = 10\sqrt{6} \quad (\because r > 0) \quad (5)$$

For $0 < r < 10\sqrt{6}$, $\frac{dV}{dr} > 0$ and for $r > 10\sqrt{6}$, $\frac{dV}{dr} < 0$

(5)

(5)

$\therefore V$ is maximum when $r = 10\sqrt{6}$. (5)

30

15. (a) Using the substitution $x = 2 \sin^2 \theta + 3$ for $0 \leq \theta \leq \frac{\pi}{4}$, evaluate $\int_3^4 \sqrt{\frac{x-3}{5-x}} dx$.

(b) Using partial fractions, find $\int \frac{1}{(x-1)(x-2)} dx$.

Let $f(t) = \int_3^t \frac{1}{(x-1)(x-2)} dx$ for $t > 2$.

Deduce that $f(t) = \ln(t-2) - \ln(t-1) + \ln 2$ for $t > 2$.

Using integration by parts, find $\int \ln(x-k) dx$, where k is a real constant.

Hence, find $\int f(t) dt$.

(c) Using the formula $\int_a^b f(x) dx = \int_a^b f(a+b-x) dx$, where a and b are constants,

show that $\int_{-\pi}^{\pi} \frac{\cos^2 x}{1+e^x} dx = \int_{-\pi}^{\pi} \frac{e^x \cos^2 x}{1+e^x} dx$.

Hence, find the value of $\int_{-\pi}^{\pi} \frac{\cos^2 x}{1+e^x} dx$.

(a) For $0 \leq \theta \leq \frac{\pi}{4}$:
 $x = 2 \sin^2 \theta + 3 \Rightarrow dx = 4 \sin \theta \cos \theta d\theta$ (5)

$x = 3 \Leftrightarrow 2 \sin^2 \theta = 0 \Leftrightarrow \theta = 0$ (5)

$x = 4 \Leftrightarrow 2 \sin^2 \theta = 1 \Leftrightarrow \sin \theta = \frac{1}{\sqrt{2}} \Leftrightarrow \theta = \frac{\pi}{4}$ (5)

Then $\int_3^4 \sqrt{\frac{x-3}{5-x}} dx = \int_0^{\frac{\pi}{4}} \sqrt{\frac{2 \sin^2 \theta}{2 - 2 \sin^2 \theta}} \cdot 4 \sin \theta \cos \theta d\theta$ (5)

$= \int_0^{\frac{\pi}{4}} 4 \sin^2 \theta d\theta$ (5)

$= 2 \int_0^{\frac{\pi}{4}} (1 - \cos 2\theta) d\theta$ (5)

$= 2 \left(\theta - \frac{1}{2} \sin 2\theta \right) \Big|_0^{\frac{\pi}{4}}$ (5)

$= \frac{\pi}{2} - 1$ (5)

40

$$(b) \quad \frac{1}{(x-1)(x-2)} = \frac{A}{(x-1)} + \frac{B}{(x-2)}$$

$$\Leftrightarrow 1 = A(x-2) + B(x-1) \text{ for } x \neq 1, 2.$$

Comparing coefficients of powers of x :

$$x^1 : A + B = 0 \quad (5)$$

$$x^0 : -2A - B = 1 \quad (5)$$

$$A = -1 \text{ and } B = 1 \quad (5)$$

$$\text{Then } \int \frac{1}{(x-1)(x-2)} dx = \int \frac{-1}{(x-1)} dx + \int \frac{1}{(x-2)} dx \quad (10)$$

$$= \ln|x-2| - \ln|x-1| + C, \text{ where } C \text{ is an arbitrary constant.}$$

$$(5) \quad (5) \quad (5)$$

40

$$f(t) = \int_3^t \frac{1}{(x-1)(x-2)} dx$$

$$= (\ln|x-2| - \ln|x-1|) \Big|_3^t \quad (5)$$

$$= \ln(t-2) - \ln(t-1) + \ln 2 \text{ for } t > 2. \quad (5)$$

10

$$\int \ln(x-k) dx = x \ln(x-k) - \int \frac{x}{(x-k)} dx \quad (5)$$

$$= x \ln(x-k) - \int 1 dx - \int \frac{k}{(x-k)} dx \quad (5)$$

$$= x \ln(x-k) - x - k \ln(x-k) + C \quad (5)$$

$$= (x-k) \ln(x-k) - x + C, \text{ where } C \text{ is an arbitrary constant.}$$

15

$$\int f(t) dt = \int \ln(t-2) dt - \int \ln(t-1) dt + \int \ln 2 dt \quad (5)$$

$$= (t-2) \ln(t-2) - t - \left[(t-1) \ln(t-1) - t \right] + t \ln 2 + D$$

$$= (t-2) \ln(t-2) - (t-1) \ln(t-1) + t \ln 2 + D, \text{ where } D \text{ is an arbitrary constant.}$$

$$(5)$$

10

(c) Using the formula $\int_a^b f(x) dx = \int_a^b (a + b - x) dx$,

$$\int_{-\pi}^{\pi} \frac{\cos^2 x}{1 + e^x} dx = \int_{-\pi}^{\pi} \frac{\cos^2(-x)}{1 + e^{-x}} dx \quad (5)$$

$$= \int_{-\pi}^{\pi} \frac{e^x \cos^2 x}{1 + e^x} dx \quad (5)$$

10

$$2 \int_{-\pi}^{\pi} \frac{\cos^2 x}{1 + e^x} dx = \int_{-\pi}^{\pi} \frac{\cos^2 x}{1 + e^{-x}} dx + \int_{-\pi}^{\pi} \frac{e^x \cos^2 x}{1 + e^x} dx \quad (5)$$

$$= \int_{-\pi}^{\pi} \frac{(1 + e^x) \cos^2 x}{(1 + e^x)} dx$$

$$= \int_{-\pi}^{\pi} \cos^2 x dx \quad (5)$$

$$= \frac{1}{2} \int_{-\pi}^{\pi} (1 + \cos 2x) dx \quad (5)$$

$$= \frac{1}{2} \left[x + \frac{1}{2} \sin 2x \right]_{-\pi}^{\pi} \quad (5)$$

$$\therefore \int_{-\pi}^{\pi} \frac{\cos^2 x}{1 + e^x} dx = \frac{\pi}{2} \quad (5)$$

25

16. Write down the coordinates of the point of intersection A of the straight lines $12x - 5y - 7 = 0$ and $y = 1$.

Let l be the bisector of the acute angle formed by these lines. Find the equation of the straight line l .

Let P be a point on l . Show that the coordinates of P can be written as $(3\lambda + 1, 2\lambda + 1)$, where $\lambda \in \mathbb{R}$.

Let $B \equiv (6, 0)$. Show that the equation of the circle with the points B and P as ends of a diameter can be written as $S + \lambda U = 0$, where $S \equiv x^2 + y^2 - 7x - y + 6$ and $U \equiv -3x - 2y + 18$.

Deduce that $S = 0$ is the equation of the circle with AB as a diameter.

Show that $U = 0$ is the equation of the straight line through B , perpendicular to l .

Find the coordinates of the fixed point which is distinct from B , and lying on the circles with the equation $S + \lambda U = 0$ for all $\lambda \in \mathbb{R}$.

Find the value of λ such that the circle given by $S = 0$ is orthogonal to the circle given by $S + \lambda U = 0$.

$$12x - 5y - 7 = 0 \text{ and } y = 1 \Rightarrow x = 1, \quad y = 1$$

$$\therefore A \equiv (1, 1)$$

(10)

10

Equations of the bisectors are given by

$$\frac{12x - 5y - 7}{13} = \pm \frac{(y - 1)}{1} \quad (10)$$

$$\Rightarrow 12x - 5y - 7 = 13(y - 1) \text{ or } 12x - 5y - 7 = -13(y - 1)$$

$$\Rightarrow 2x - 3y + 1 = 0 \text{ or } 3x + 2y - 5 = 0 \quad (5) + (5)$$

The angle θ between $y = 1$ and $2x - 3y + 1 = 0$, is given by

$$\tan \theta = \left| \frac{\frac{2}{3} - 0}{1 + \frac{2}{3}(0)} \right| = \frac{2}{3} < 1 \quad (5)$$

$$\therefore l: 2x - 3y + 1 = 0. \quad (5)$$

30

Note that for a point (x, y) on l ;

$$\frac{(x-1)}{3} = \frac{(y-1)}{2} = \lambda \text{ (say)}$$

(5) (5)

$$\Rightarrow x = 3\lambda + 1, \quad y = 2\lambda + 1.$$

10

$\therefore P \equiv (3\lambda + 1, 2\lambda + 1), \quad \lambda \in \mathbb{R}.$

Note that $B \equiv (6, 0)$ and $P \equiv (3\lambda + 1, 2\lambda + 1)$

\therefore Equation of the circle with BP as a diameter is given by

$$(x-6)(x-(3\lambda+1)) + (y-0)(y-(2\lambda+1)) = 0 \quad (10)$$

i.e. $(x^2 + y^2 - 7x - y + 6) + \lambda(-3x - 2y + 18) = 0 \quad (5)$

This is of the form $S + \lambda U = 0$, where $S \equiv x^2 + y^2 - 7x - y + 6$ and $U \equiv -3x - 2y + 18$.

(5)

(5)

25

$S = 0$ corresponds to $\lambda = 0. \Rightarrow P = (1, 1) \equiv A. \quad (5)$

$\therefore S = 0$ is the equation of the circle with AB as a diameter. (5)

10

Since the slope of l is $\frac{2}{3}$, the equation of the line perpendicular to l passing through

B is $3x + 2y + \mu = 0$, μ to be determined. (10)

Since B lies on $3x + 2y + \mu = 0$, we have $18 + \mu = 0 \Rightarrow \mu = -18. \quad (5)$

\therefore Required equation is $3x + 2y - 18 = 0 \quad (5)$

i.e. $U = -3x - 2y + 18 = 0.$

20

$\lambda \in \mathbb{R}, S + \lambda U = 0$ passes through the intersection point of $S = 0$ and $U = 0 \quad (10)$

One of these points is B and the other point C is the intersection point of l and $U = 0. \quad (10)$

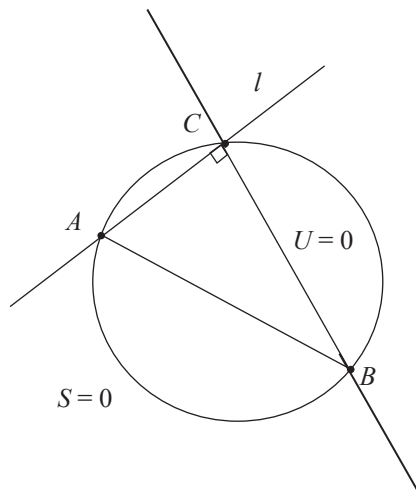

∴ The coordinates of C is given by

$$u \equiv -3x - 2y + 18 = 0$$

$$\text{and } l \equiv 2x - 3y + 1 = 0$$

$$\Rightarrow x = 4 \text{ and } y = 3$$

$$\therefore C \equiv (4, 3). \quad \textcircled{5}$$

25

The circles ;

$S = 0$ and $S + \lambda U = 0$ are orthogonal

$$\Leftrightarrow 2 \left(-\frac{1}{2} (3\lambda + 7) \right) \left(-\frac{7}{2} \right) + 2 \left(-\frac{1}{2} (2\lambda + 1) \right) \left(-\frac{1}{2} \right) = 6 + 18\lambda + 6$$

$\textcircled{5}$
 $\textcircled{5}$
 $\textcircled{5}$

$$\Leftrightarrow 13\lambda = 26 \quad \textcircled{5}$$

$$\Leftrightarrow \lambda = 2.$$

20

17. (a) Write down $\sin(A+B)$ in terms of $\sin A$, $\cos A$, $\sin B$ and $\cos B$, and obtain a similar expression for $\sin(A-B)$.

Deduce that

$$2 \sin A \cos B = \sin(A+B) + \sin(A-B) \text{ and}$$

$$2 \cos A \sin B = \sin(A+B) - \sin(A-B).$$

Hence, solve $2 \sin 3\theta \cos 2\theta = \sin 7\theta$ for $0 < \theta < \frac{\pi}{2}$.

(b) In a triangle ABC , the point D lies on AC such that $BD = DC$ and $AD = BC$. Let $\hat{BAC} = \alpha$ and $\hat{ACB} = \beta$. Using the Sine Rule for suitable triangles, show that $2 \sin \alpha \cos \beta = \sin(\alpha + 2\beta)$.

If $\alpha : \beta = 3 : 2$, using the last result in (a) above, show that $\alpha = \frac{\pi}{6}$.

(c) Solve $2 \tan^{-1} x + \tan^{-1}(x+1) = \frac{\pi}{2}$. Hence, show that $\cos\left(\frac{\pi}{4} - \frac{1}{2} \tan^{-1}\left(\frac{4}{3}\right)\right) = \frac{3}{\sqrt{10}}$.

(a) $\sin(A+B) = \sin A \cos B + \cos A \sin B$ ————— (1) (5)

Now $\sin(A-B) = \sin(A+(-B))$ (5)

$$= \sin A \cos(-B) + \cos A \sin(-B)$$

$\therefore \sin(A-B) = \sin A \cos B - \cos A \sin B$ ————— (2) (5)

15

(1) + (2) $\Rightarrow \sin(A+B) + \sin(A-B) = 2 \sin A \cos B$, (5)

(1) - (2) $\Rightarrow \sin(A+B) - \sin(A-B) = 2 \cos A \sin B$. (5)

10

$0 < \theta < \frac{\pi}{2}$

$$2 \sin 3\theta \cos 2\theta = \sin 7\theta,$$

$$\Leftrightarrow \sin 5\theta + \sin \theta = \sin 7\theta$$
 (5)

$$\Leftrightarrow \sin 7\theta - \sin 5\theta - \sin \theta = 0$$

$$\Leftrightarrow \sin(6\theta + \theta) - \sin(6\theta - \theta) - \sin \theta = 0$$
 (5)

$$\Leftrightarrow 2 \cos 6\theta \sin \theta - \sin \theta = 0$$

$$\Leftrightarrow \sin \theta (2 \cos 6\theta - 1) = 0$$

$$\Leftrightarrow \cos 6\theta = \frac{1}{2} \text{ since } 0 < \theta < \frac{\pi}{2}, \sin \theta > 0$$

5

$$\Rightarrow 6\theta = 2n\pi \pm \frac{\pi}{3}; n \in \mathbb{Z}. \quad (5) + (5)$$

$$\Rightarrow \theta = \frac{n\pi}{3} \pm \frac{\pi}{18}; n \in \mathbb{Z}.$$

$$\Rightarrow \theta = \frac{\pi}{18}, \frac{5\pi}{18}, \frac{7\pi}{18}, (\because 0 < \theta < \frac{\pi}{2}) \quad (5)$$

30

(b)

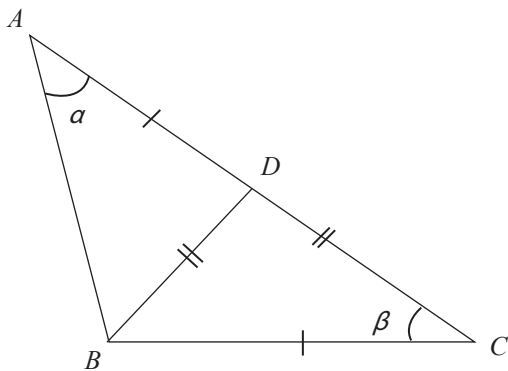

Note that

$$\hat{C}BD = \beta, \hat{A}DB = 2\beta,$$

$$\text{and } \hat{A}BD = \pi - (\alpha + 2\beta)$$

Using the sine Rule :

for the triangle ABD , we have

$$\frac{BD}{\sin \hat{B}AD} = \frac{AD}{\sin \hat{A}BD} \quad (10)$$

$$\Rightarrow \frac{BD}{\sin \alpha} = \frac{AD}{\sin (\pi - (\alpha + 2\beta))}$$

$$\Rightarrow \frac{BD}{\sin \alpha} = \frac{AD}{\sin (\alpha + 2\beta)} \quad (5) \quad (1)$$

for the triangle BDC , we have

$$\frac{CD}{\sin \hat{D}BC} = \frac{BC}{\sin \hat{B}DC} \quad (10)$$

$$\Rightarrow \frac{CD}{\sin \beta} = \frac{BC}{\sin 2\beta} \quad (5) \quad (2)$$

$\therefore BD = DC$ and $AD = BC$, from (1) and (2), we get

$$\frac{\sin \alpha}{\sin \beta} = \frac{\sin (\alpha + 2\beta)}{\sin 2\beta} \quad (5)$$

$$\Rightarrow 2 \sin \alpha \cos \beta = \sin (\alpha + 2\beta). \quad (5)$$

40

If $\alpha : \beta = 3 : 2$, then we have

$$2 \sin \alpha \cos \frac{2\alpha}{3} = \sin \frac{7\alpha}{3} \quad (5)$$

$$\Rightarrow 2 \sin 3 \left(\frac{\alpha}{3}\right) \cos 2 \left(\frac{\alpha}{3}\right) = \sin 7 \left(\frac{\alpha}{3}\right) \quad (5)$$

$$\Rightarrow \frac{\alpha}{3} = \frac{\pi}{18}, \frac{5\pi}{18}, \frac{7\pi}{18}.$$

$$\Rightarrow \alpha = \frac{\pi}{6}, \frac{15\pi}{18}, \frac{21\pi}{18} \quad (5)$$

$\because BC = AD < AC$, α must be an acute angle.

$$\therefore \alpha = \frac{\pi}{6}. \quad (5)$$

20

(c) $2 \tan^{-1}x + \tan^{-1}(x+1) = \frac{\pi}{2}$

Let $\alpha = \tan^{-1}(x)$ and $\beta = \tan^{-1}(x+1)$. Note that $x \neq \pm 1$.

$$\text{Then } 2\alpha + \beta = \frac{\pi}{2}. \quad (5)$$

$$\Leftrightarrow 2\alpha = \frac{\pi}{2} - \beta$$

$$\Leftrightarrow \tan 2\alpha = \tan \left(\frac{\pi}{2} - \beta\right) \quad (5)$$

$$\Leftrightarrow \frac{2 \tan \alpha}{1 - \tan^2 \alpha} = \cot \beta \quad (5) + (5)$$

$$\Leftrightarrow \frac{2x}{1 - x^2} = \frac{1}{x+1} \quad (5)$$

$$\Leftrightarrow 2x = 1 - x \quad (\because x \neq \pm 1)$$

$$\Leftrightarrow x = \frac{1}{3}. \quad (5)$$

25

Note that

$$2 \tan^{-1}\left(\frac{1}{3}\right) + \tan^{-1}\left(\frac{4}{3}\right) = \frac{\pi}{2}.$$

$$\Rightarrow \frac{\pi}{4} - \frac{1}{2} \tan^{-1}\left(\frac{4}{3}\right) = \tan^{-1}\left(\frac{1}{3}\right)$$

$$\Rightarrow \cos\left(\frac{\pi}{4} - \frac{1}{2} \tan^{-1}\left(\frac{4}{3}\right)\right) = \cos\left(\tan^{-1}\left(\frac{1}{3}\right)\right)$$

(5)

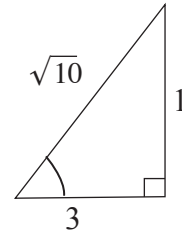

$$\therefore \cos\left(\frac{\pi}{4} - \frac{1}{2} \tan^{-1}\left(\frac{4}{3}\right)\right) = \frac{3}{\sqrt{10}} \quad (5)$$

10