

ශ්‍රී ලංකා විභාග දෙපාර්තමේන්තුව ශ්‍රී ලංකා විභාග දෙපාර්තමේන්තුව ශ්‍රී ලංකා විභාග දෙපාර්තමේන්තුව ශ්‍රී ලංකා විභාග දෙපාර්තමේන්තුව ශ්‍රී ලංකා විභාග දෙපාර්තමේන්තුව  
 இலங்கைப் பரீட்சைத் திணைக்களம் இலங்கைப் பரීட்சைத் திணைக்களம் இலங்கைப் பரීட்சைத் திணைக்களம் இலங்கைப் பரීட்சைத் திணைக்களம் இலங்கைப் பரීட்சைத் திணைக்களம்  
 Department of Examinations, Sri Lanka Department of Examinations, Sri Lanka Department of Examinations, Sri Lanka Department of Examinations, Sri Lanka Department of Examinations, Sri Lanka  
 இலங்கைப் பரීட்சைத் திணைக்களம் இலங்கைப் பரීட்சைத் திணைக்களம் இலங்கைப் பரීட்சைத் திணைக்களம் இலங்கைப் பரීட்சைத் திணைக்களம் இலங்கைப் பரීட்சைத் திணைக்களம்  
 Department of Examinations, Sri Lanka

අධ්‍යයන පොදු සහතික පත්‍ර (උසස් පෙළ) විභාගය, 2022 (2023)  
 கல்விப் பொதுத் தராதரப் பத்திர (உயர் தர)ப் பரீட்சை, 2022 (2023)  
 General Certificate of Education (Adv. Level) Examination, 2022 (2023)

රසායන විද්‍යාව I  
 இரசாயனவியல் I  
 Chemistry I

02 S I

පැය දෙකයි  
 இரண்டு மணித்தியாலம்  
 Two hours

උපදෙස්:

- \* ආවර්තිතා වගුවක් සපයා ඇත.
- \* මෙම ප්‍රශ්න පත්‍රය පිටු 09 කින් යුක්ත වේ.
- \* සියලුම ප්‍රශ්නවලට පිළිතුරු සපයන්න.
- \* ගණක යන්ත්‍ර භාවිතයට ඉඩ දෙනු නොලැබේ.
- \* පිළිතුරු පත්‍රයේ නියමිත ස්ථානයේ ඔබේ විභාග අංකය ලියන්න.
- \* පිළිතුරු පත්‍රයේ පිටුපස දී ඇති අනෙක් උපදෙස් සැලකිලිමත්ව කියවන්න.
- \* 1 සිට 50 තෙක් එක් එක් ප්‍රශ්නයට (1), (2), (3), (4), (5) යන පිළිතුරුවලින් නිවැරදි හෝ ඉතාමත් ගැළපෙන හෝ පිළිතුර තෝරා ගෙන, එය පිළිතුරු පත්‍රයේ පිටුපස දැක්වෙන උපදෙස් පරිදි කතිරයක් (X) යොදා දැක්වන්න.

සාර්වත්‍ර වායු නියතය  $R = 8.314 \text{ J K}^{-1} \text{ mol}^{-1}$       ජලජන්කයේ නියතය  $h = 6.626 \times 10^{-34} \text{ J s}$   
 ඇවගාඩරෝ නියතය  $N_A = 6.022 \times 10^{23} \text{ mol}^{-1}$       ආලෝකයේ ප්‍රවේගය  $c = 3 \times 10^8 \text{ m s}^{-1}$

1. පහත දැක්වෙන ඉලෙක්ට්‍රෝනික සංක්‍රමණ අතුරෙන්, කුමක් පරමාණුක හයිඩ්‍රජන්වල රේඛා වර්ණාවලියේ දෘශ්‍ය පරාසයට අයත් වේ ද? ( $n =$  ප්‍රධාන ක්වොන්ටම් අංකය)
  - (1)  $n = 5 \rightarrow n = 3$
  - (2)  $n = 4 \rightarrow n = 2$
  - (3)  $n = 1 \rightarrow n = 2$
  - (4)  $n = 3 \rightarrow n = 1$
  - (5)  $n = 2 \rightarrow n = 1$
2. වැරදි වගන්තිය තෝරන්න.
  - (1) පවුලි බහිෂ්කාරක මූලධර්මය කාක්ෂිකයක තුන්වන ඉලෙක්ට්‍රෝනයක් පැවතීමේ හැකියාව බැහැර කරයි.
  - (2) පොටෑසියම් පරමාණුවක, ක්වොන්ටම් අංක  $n$  (ප්‍රධාන ක්වොන්ටම් අංකය) = 3 සහ  $m_l$  (මූලික ක්වොන්ටම් අංකය) = 0 ඇති ඉලෙක්ට්‍රෝන සංඛ්‍යාව 4 කි.
  - (3) නයිට්‍රජන් (N) හි සංයුජතා ඉලෙක්ට්‍රෝනයකට දැනෙන සඵල න්‍යෂ්ටික ආරෝපණය කාබන් (C) හි සංයුජතා ඉලෙක්ට්‍රෝනයකට දැනෙන සඵල න්‍යෂ්ටික ආරෝපණයට වඩා විශාල වෙයි.
  - (4)  $\text{Na}^+, \text{Mg}^{2+}, \text{K}^+$  සහ  $\text{Ca}^{2+}$  අයන අතුරෙන් විශාලත්වයෙන් එකිනෙකට වඩාත්ම ආසන්න අයන දෙක වන්නේ  $\text{K}^+$  සහ  $\text{Mg}^{2+}$  ය.
  - (5) කාබන්වල ඉලෙක්ට්‍රෝන ලබාගැනීමේ ශක්තිය සෘණ වේ.
3. Be, B සහ O වල දෙවන අයනීකරණ ශක්තිය ( $\text{X}^+(\text{g}) \rightarrow \text{X}^{2+}(\text{g}) + e$ ) වැඩිවන අනුපිළිවෙළ වනුයේ,
  - (1)  $\text{Be} < \text{B} < \text{O}$
  - (2)  $\text{Be} < \text{O} < \text{B}$
  - (3)  $\text{B} < \text{O} < \text{Be}$
  - (4)  $\text{B} < \text{Be} < \text{O}$
  - (5)  $\text{O} < \text{Be} < \text{B}$
4.  $\text{F}_3\text{ClO}$ ,  $\text{FCIO}_2$  සහ  $\text{FCIO}_3$  හි හැඩයන් වනුයේ පිළිවෙළින්,
  - (1) වතුස්තලීය, තලීය ත්‍රිකෝණාකාර සහ සීසෝ ය.
  - (2) තලීය සමවතුරුසාකාර, තලීය ත්‍රිකෝණාකාර සහ වතුස්තලීය ය.
  - (3) සීසෝ, ත්‍රිආනති පිරමීඩාකාර සහ තලීය සමවතුරුසාකාර ය.
  - (4) වතුස්තලීය, ත්‍රිආනති පිරමීඩාකාර සහ සීසෝ ය.
  - (5) සීසෝ, ත්‍රිආනති පිරමීඩාකාර සහ වතුස්තලීය ය.

5. පහත දී ඇති සංයෝගයේ IUPAC නාමය කුමක් ද?

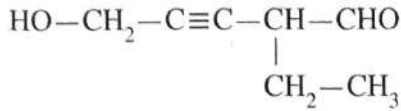

- (1) 5-hydroxy-2-ethylpent-3-ynal
- (2) 3-formylhex-4-yn-6-ol
- (3) 2-ethyl-5-hydroxypent-3-ynal
- (4) 4-formyl-1-hydroxy-2-hexyne
- (5) 4-formylhex-2-yn-1-ol

6. අල්ප වශයෙන් ද්‍රාව්‍ය වන  $\text{AB}_2$  ලවණයේ සංතෘප්ත ජලීය ද්‍රාවණයක්,  $25^\circ\text{C}$  දී සාදාගන්නා ලදී.  $\text{AB}_2$  හි ද්‍රාව්‍යතා ගුණිතය  $25^\circ\text{C}$  දී  $3.20 \times 10^{-8} \text{ mol}^3 \text{ dm}^{-9}$  වේ. සංතෘප්ත ද්‍රාවණයේ  $\text{B}^-$  අයනයේ සාන්ද්‍රණය ( $\text{mol dm}^{-3}$ ) වන්නේ,

- (1)  $(1.6)^{\frac{1}{2}} \times 10^{-4}$  (2)  $(3.2)^{\frac{1}{2}} \times 10^{-4}$  (3)  $(3.2)^{\frac{1}{3}} \times 10^{-3}$  (4)  $2.0 \times 10^{-3}$  (5)  $4.0 \times 10^{-3}$

7. නිවැරදි ප්‍රකාශය තෝරන්න.

- (1)  $\text{F}^-$ ,  $\text{Cl}^-$  සහ  $\text{S}^{2-}$  අයනවල ධ්‍රැවණශීලතාව  $\text{F}^- < \text{S}^{2-} < \text{Cl}^-$  යන පිළිවෙලට වැඩි වේ.
- (2)  $\text{Li}^+$ ,  $\text{Na}^+$  සහ  $\text{Mg}^{2+}$  වල ධ්‍රැවීකරණ බලය  $\text{Mg}^{2+} > \text{Na}^+ > \text{Li}^+$  යන පිළිවෙලට අඩු වේ.
- (3)  $\text{O}$ ,  $\text{F}$ ,  $\text{Cl}$  සහ  $\text{S}$  වල විද්‍යුත් ඍණතාව  $\text{F} > \text{O} > \text{S} > \text{Cl}$  යන පිළිවෙලට අඩු වේ.
- (4)  $\text{Xe}$ ,  $\text{CH}_4$ ,  $\text{CH}_3\text{NH}_2$  සහ  $\text{CH}_3\text{OH}$  වල තාපාංක  $\text{CH}_4 < \text{Xe} < \text{CH}_3\text{NH}_2 < \text{CH}_3\text{OH}$  යන පිළිවෙලට වැඩි වේ.
- (5)  $\text{N}_2$ ,  $\text{O}_2$ ,  $\text{F}_2$  සහ  $\text{HF}$  වල අන්තර් පරමාණුක බන්ධන දිග  $\text{N}_2 < \text{O}_2 < \text{F}_2 < \text{HF}$  යන පිළිවෙලට වැඩි වේ.

8. P සහ Q සංයෝග එකිනෙකෙහි පාරත්‍රීමාන සමාවයවික වේ. පහත දැක්වෙන ඒවායින් P සහ Q සංයෝගයන්හි අණුක සූත්‍රය විය හැක්කේ කුමක් ද?

- (1)  $\text{C}_5\text{H}_{10}$  (2)  $\text{C}_3\text{H}_6$  (3)  $\text{C}_4\text{H}_6$  (4)  $\text{C}_4\text{H}_{10}\text{O}$  (5)  $\text{C}_4\text{H}_{10}$

9.  $\text{CH}_4$ ,  $\text{CH}_3\text{Cl}$ ,  $\text{H}_2\text{CO}$ ,  $\text{HCN}$  සහ  $\text{NCO}^-$  වල කාබන් (C) පරමාණුවේ විද්‍යුත් ඍණතාව වැඩිවන අනුපිළිවෙල වනුයේ,

- (1)  $\text{CH}_4 < \text{H}_2\text{CO} < \text{CH}_3\text{Cl} < \text{HCN} < \text{NCO}^-$
- (2)  $\text{CH}_3\text{Cl} < \text{CH}_4 < \text{H}_2\text{CO} < \text{HCN} < \text{NCO}^-$
- (3)  $\text{CH}_4 < \text{CH}_3\text{Cl} < \text{H}_2\text{CO} < \text{HCN} < \text{NCO}^-$
- (4)  $\text{CH}_4 < \text{CH}_3\text{Cl} < \text{NCO}^- < \text{H}_2\text{CO} < \text{HCN}$
- (5)  $\text{NCO}^- < \text{HCN} < \text{H}_2\text{CO} < \text{CH}_4 < \text{CH}_3\text{Cl}$

10. X කාබනික සංයෝගය 2,4-DNP සමග පිරියම් කළ විට වර්ණවත් අවක්ෂේපයක් ලබා නොදෙයි. ආම්ලික  $\text{K}_2\text{Cr}_2\text{O}_7$  සමග X සංයෝගය පිරියම් කළ විට Y ඵලය සෑදේ. Y ඵලය 2,4-DNP සමග වර්ණවත් අවක්ෂේපයක් ලබා දේ. Y ජලීය  $\text{Na}_2\text{CO}_3$  ද්‍රාවණයක් සමග පිරියම් කළ විට  $\text{CO}_2$  පිටකරයි. X සංයෝගය විය හැක්කේ,

- (1)  $\begin{array}{c} \text{OH} \\ | \\ \text{CH}_3\text{CH}_2\text{CHCH}_2\text{CH}_2\text{CHO} \end{array}$  (2)  $\begin{array}{c} \text{OH} \\ | \\ \text{CH}_3\text{CH}_2\text{CCH}_2\text{CH}_2\text{CH}_2\text{OH} \\ | \\ \text{CH}_3 \end{array}$
- (3)  $\begin{array}{c} \text{OH} \\ | \\ \text{CH}_3\text{CH}_2\text{CHCH}_2\text{CH}_2\text{CH}_2\text{OH} \end{array}$  (4)  $\begin{array}{c} \text{OH} \quad \text{OH} \\ | \quad | \\ \text{CH}_3\text{CH}_2\text{CHCH}_2\text{CH}_2\text{CHCH}_3 \end{array}$
- (5)  $\begin{array}{c} \text{OH} \\ | \\ \text{CH}_3\text{CHCH}_2\text{CH}_2\text{CO}_2\text{CH}_3 \end{array}$

11. 500 K හිදී දෘඪ සංවෘත බඳුනක් තුළ පවතින පහත සමතුලිතතාවය සලකන්න.

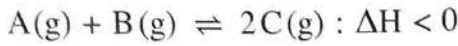

උෂ්ණත්වය 750 K ට වැඩි කළ විට සමතුලිතතා නියතය  $K_p$  මත සිදුවන බලපෑම පහත සඳහන් කුමක් මගින් විස්තර/පැහැදිලි කරයි ද?

- (1) පීඩනය වෙනස් නොවන නිසා  $K_p$  වෙනස් නොවේ.
- (2) ඉදිරි ප්‍රතික්‍රියාවෙහි සක්‍රියන ශක්තිය අඩුවන බැවින්  $K_p$  වැඩි වේ.
- (3) එල අණු සංඛ්‍යාව හා ප්‍රතික්‍රියක අණු සංඛ්‍යාව එකිනෙකට සමාන බැවින්  $K_p$  වෙනස් නොවේ.
- (4) ආපසු ප්‍රතික්‍රියාව තාප අවශෝෂක බැවින් ඉදිරි ප්‍රතික්‍රියාවෙහි නැඹුරුතාවය වැඩි වී  $K_p$  අඩු වේ.
- (5) ඉදිරි ප්‍රතික්‍රියාව තාපදායක බැවින් ආපසු ප්‍රතික්‍රියාවෙහි නැඹුරුතාවය වැඩි වී  $K_p$  අඩු වේ.

12.  $X(aq) + Y(aq) \rightarrow Z(aq)$  ප්‍රතික්‍රියාව සඳහා දී ඇති උෂ්ණත්වයකදී සිදු කළ ආරම්භක ශීඝ්‍රතා මැනීමේ පරීක්ෂණයක විස්තර පහත වගුවෙහි දක්වා ඇත.

පරීක්ෂණය	$[X(aq)]_0 / \text{mol dm}^{-3}$	$[Y(aq)]_0 / \text{mol dm}^{-3}$	ආරම්භක ශීඝ්‍රතාවය / $\text{mol dm}^{-3} \text{s}^{-1}$
①	0.40	0.10	R
②	0.20	0.20	?

① පරීක්ෂණයේදී  $Z(aq)$  සෑදීමේ ආරම්භක ශීඝ්‍රතාවය R වේ. ප්‍රතික්‍රියාව  $X(aq)$  අනුබද්ධයෙන් පළමු පෙළ සහ  $Y(aq)$  අනුබද්ධයෙන් දෙවන පෙළ වේ. ② පරීක්ෂණයේදී  $Z(aq)$  සෑදීමේ ආරම්භක ශීඝ්‍රතාවය වන්නේ,

- (1)  $\frac{R}{4}$       (2)  $\frac{R}{2}$       (3) R      (4) 2R      (5) 4R

13. සංඉද්ධ අයන(II) ඔක්සලේට් ( $\text{FeC}_2\text{O}_4$ ) 0.4314 g සාම්පලයක් වැඩිපුර තනුක  $\text{H}_2\text{SO}_4$  හි ද්‍රවණය කරන ලදී. මෙම සම්පූර්ණ ද්‍රාවණයම  $0.060 \text{ mol dm}^{-3} \text{ KMnO}_4$  ද්‍රාවණයක් සමග අනුමාපනය කරන ලදී. අන්ත ලක්ෂ්‍යයේදී බියුරෙට්ටු පාඨාංකය වනුයේ, ( $\text{FeC}_2\text{O}_4$  වල සාපේක්ෂ අණුක ස්කන්ධය = 143.8)

- (1)  $20.00 \text{ cm}^3$       (2)  $25.00 \text{ cm}^3$       (3)  $30.00 \text{ cm}^3$       (4)  $40.00 \text{ cm}^3$       (5)  $50.00 \text{ cm}^3$

14. දී ඇති උෂ්ණත්වයකදී රේඛනය කරන ලද  $1.0 \text{ dm}^3$  දෘඪ සංවෘත බඳුනක් තුළට  $\text{H}_2\text{S}(g)$  යම් මවුල ප්‍රමාණයක් ඇතුළු කර පද්ධතිය පහත දැක්වෙන සමතුලිතතාවයට එළඹීමට ඉඩ හරින ලදී.

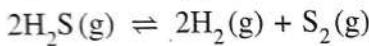

සමතුලිතතාවයේදී  $\text{H}_2\text{S}(g)$  වලින්  $x$  භාගයක් (fraction  $x$ ) විශෝජනය වී ඇති බව සොයාගන්නා ලදී. සමතුලිතතාවයේදී බඳුන තුළ මුළු පීඩනය  $P$  විය. මෙම පද්ධතියේ සමතුලිතතා නියතය  $K_p$  පහත සඳහන් කුමක් මගින් ලබා දේ ද?

- (1)  $\frac{x^2 P}{(2+x)(1-x)^2}$       (2)  $\frac{(2+x)(1-x)^2 P}{x^3}$       (3)  $\frac{x^3 P}{(2+x)(1-x)^2}$   
 (4)  $\frac{(1-x)P}{x^2(1-x)^2}$       (5)  $\frac{(2+x)(1-x)^2}{x^3 P}$

15. දී ඇති උෂ්ණත්වයකදී  $0.10 \text{ mol dm}^{-3}$  නොදන්නා අම්ලයක  $25.00 \text{ cm}^3$  ක්,  $0.10 \text{ mol dm}^{-3}$  නොදන්නා භස්මයක් සමග සිදු කළ අනුමාපනයකදී ලබාගත් pH වක්‍රය දැකුණුපසින් පෙන්වා ඇත.

පහත සඳහන් කුමක් මෙම අනුමාපනය සඳහා යොදාගත් අම්ලය සහ භස්මය පිළිබඳව වඩාත් යෝග්‍ය වේ ද?

- (1) ඒක-භාස්මික ප්‍රබල අම්ලයක්, ඒක-ආම්ලික ප්‍රබල භස්මයක් සමග
- (2) ඒක-භාස්මික ප්‍රබල අම්ලයක්, ඒක-ආම්ලික දුබල භස්මයක් සමග
- (3) ද්වි-භාස්මික ප්‍රබල අම්ලයක්, ඒක-ආම්ලික ප්‍රබල භස්මයක් සමග
- (4) ඒක-භාස්මික දුබල අම්ලයක්, ඒක-ආම්ලික දුබල භස්මයක් සමග
- (5) ඒක-භාස්මික දුබල අම්ලයක්, ඒක-ආම්ලික ප්‍රබල භස්මයක් සමග

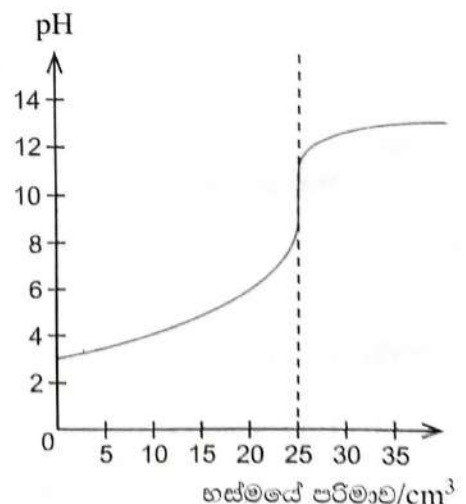

16. s සහ p ගොනුවල මූලද්‍රව්‍ය සම්බන්ධයෙන් පහත දී ඇති කුමන ප්‍රකාශය අසත්‍ය ද?
- (1) සෙනෝන් (Xe) නිෂ්ක්‍රීය වායුවක් වුවත් ඔක්සිකරණ අංක +2, +4 සහ +6 වන සංයෝග සාදයි.
  - (2) හයිඩ්‍රජන් හේලයිඩ අතුරෙන්, වැඩිම බන්ධන විභවන ශක්තිය ඇත්තේ HF වලට ය.
  - (3) දෙවන (II) කාණ්ඩයේ මූලද්‍රව්‍යයන්හි හයිඩ්‍රොක්සයිඩ්වල ජලයෙහි ද්‍රාව්‍යතාවය කාණ්ඩයේ පහළට යන විට අඩුවන අතර, ඒවායෙහි සල්ෆේට්වල ද්‍රාව්‍යතාවය වැඩි වේ.
  - (4) පළමුවන (I) කාණ්ඩයේ ලෝහ අතුරෙන් (Li සිට Cs දක්වා) සීසියම්වලට අඩුම ද්‍රවාංකය ඇත.
  - (5)  $\text{NH}_2\text{OH}$  හි නයිට්‍රජන්වල ඔක්සිකරණ අංකය -1 වේ.

17.  $25^\circ\text{C}$  දී, ඕකරයක ඇති  $x \text{ mol dm}^{-3} \text{CH}_3\text{COOH(aq)}$  ද්‍රාවණ  $V_1 \text{ cm}^3$  කට  $y \text{ mol dm}^{-3} (y > x) \text{NaOH(aq)}$  ද්‍රාවණ  $V_2 \text{ cm}^3 (V_2 > V_1)$  එකතු කරන ලදී. අවසාන මිශ්‍රණයෙහි pH අගය වනුයේ, ( $25^\circ\text{C}$  දී ජලයෙහි විභවන නියතය  $K_w$  වේ.)

- (1)  $\text{p}K_w - \log\left\{\frac{V_2y - V_1x}{V_1 + V_2}\right\}$
- (2)  $\text{p}K_w + \log\left\{\frac{V_2y - V_1x}{V_1 + V_2}\right\}$
- (3)  $\text{p}K_w$
- (4)  $-\text{p}K_w - \log\left\{\frac{V_2y - V_1x}{V_1 + V_2}\right\}$
- (5)  $-\text{p}K_w + \log\left\{\frac{V_2y - V_1x}{V_1 + V_2}\right\}$

18. සමමත තත්ත්ව යටතේදී පහත දී ඇති ප්‍රතික්‍රියාව සඳහා පහත සඳහන් කුමන වගන්තිය වැරදි වේ ද?

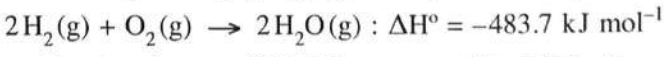

- (1) ප්‍රතික්‍රියා මවුල එකක් සඳහා 483.7 kJ ක තාප ශක්තියක් පිට වේ.
- (2) වැය වූ  $\text{H}_2(\text{g})$  මවුල දෙකක් සඳහා 483.7 kJ ක තාප ශක්තියක් පිට වේ.
- (3) සෑදුන  $\text{H}_2\text{O}(\text{g})$  මවුල දෙකක් සඳහා 483.7 kJ ක තාප ශක්තියක් පිට වේ.
- (4)  $4\text{H}_2(\text{g}) + 2\text{O}_2(\text{g}) \rightarrow 4\text{H}_2\text{O}(\text{g})$  ප්‍රතික්‍රියාව සඳහා 967.4 kJ ක තාප ශක්තියක් පිට වේ.
- (5) වැය වූ  $\text{O}_2(\text{g})$  මවුල එකක් සඳහා 241.85 kJ ක තාප ශක්තියක් පිට වේ.

19. පහත සඳහන් කුමන වගන්තිය ගැල්වානීය කෝෂයක් සඳහා වැරදි වේ ද?

- (1) කෝෂ ප්‍රතික්‍රියාව ස්වයං-සිද්ධ වේ.
- (2) කෝෂය විද්‍යුත් ශක්තිය නිපදවයි.
- (3) කැතෝඩය සෘණ ආරෝපිත වේ.
- (4) ඔක්සිහරණ අර්ධ-ප්‍රතික්‍රියාව කැතෝඩය මත සිදු වේ.
- (5) ඔක්සිකරණ අර්ධ-ප්‍රතික්‍රියාව ඇනෝඩය මත සිදු වේ.

20. ට්‍රෝමොබෙන්සීන්හි සම්ප්‍රයුක්ත ව්‍යුහයක් නොවන්නේ පහත දැක්වෙන ඒවායින් කුමක් ද?

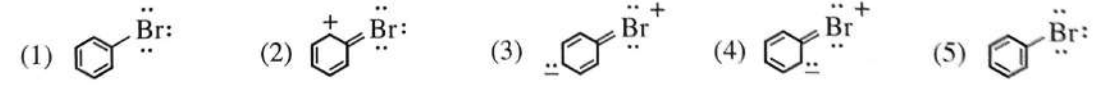

21. පහත සඳහන් කුමන උෂ්ණත්ව හා පීඩන තත්ත්ව යටතේදී තාත්වික වායුවක් පරිපූර්ණ වායුවක් ලෙස හැසිරීමට නැඹුරු වේ ද?

උෂ්ණත්වය	පීඩනය
(1) ඉතා ඉහළ	ඉතා ඉහළ
(2) ඉතා ඉහළ	ඉතා පහළ
(3) ඉතා පහළ	ඉතා ඉහළ
(4) ඉතා පහළ	ඉතා පහළ
(5) සියලුම උෂ්ණත්ව	ඉතා පහළ

22. සමමත උෂ්ණත්වයේ හා පීඩනයේ පවතින සර්වසම දෘඪ සංවෘත බඳුන් දෙකක් තුළ  $\text{H}_2(\text{g}) 1.0 \text{ mol}$  ක් හා  $\text{O}_2(\text{g}) 2.0 \text{ mol}$  ක් අඩංගු වේ. ඉහත පද්ධති දෙක සම්බන්ධව, පහත සඳහන් කුමක් සත්‍ය වේ ද?

- (1)  $\text{H}_2(\text{g})$  හා  $\text{O}_2(\text{g})$  දෙකටම එකම මධ්‍ය-වාලක ශක්තියක් ඇත.
- (2)  $\text{H}_2(\text{g})$  හා  $\text{O}_2(\text{g})$  දෙකටම එකම මධ්‍ය-වේගයක් ඇත.
- (3)  $\text{H}_2(\text{g})$  හා  $\text{O}_2(\text{g})$  දෙකටම එකම ස්කන්ධයක් ඇත.
- (4)  $\text{H}_2(\text{g})$  හා  $\text{O}_2(\text{g})$  දෙකටම එකම ඝනත්වයක් ඇත.
- (5)  $\text{H}_2(\text{g})$  හා  $\text{O}_2(\text{g})$  දෙකටම එකම විසර්ජන වේගයක් ඇත.

AI/2022(2023)/02/S-1

23. 25 °C දී X(s) සහයෙහි මවුලික සඳාචණ (dissolution) එන්ට්‍රොපි වෙනස  $\Delta S_{\text{dissol}}^{\circ}$   $70 \text{ J K}^{-1} \text{ mol}^{-1}$  හා X(s) හි මවුලික එන්ට්‍රොපිය  $100 \text{ J K}^{-1} \text{ mol}^{-1}$  වේ. පහත සඳහන් කුමක් X(aq) හි මවුලික එන්ට්‍රොපිය ( $\text{J K}^{-1} \text{ mol}^{-1}$ ) දක්වයි ද?

- (1) -170                      (2) -30                      (3) 0                      (4) +30                      (5) +170

24.  $\text{CH}_3-\text{CH}=\text{CH}_2$  සහ HBr අතර සිදුවන ඉලෙක්ට්‍රෝනික ආකලන ප්‍රතික්‍රියාවේ ප්‍රධාන ඵලය සලකන්න. ප්‍රධාන ඵලය ලබාදෙන ප්‍රතික්‍රියාවේ යන්ත්‍රණයේ නිවැරදි පියවරක් දක්වන්නේ පහත දී ඇති ඒවායින් කුමක් ද?

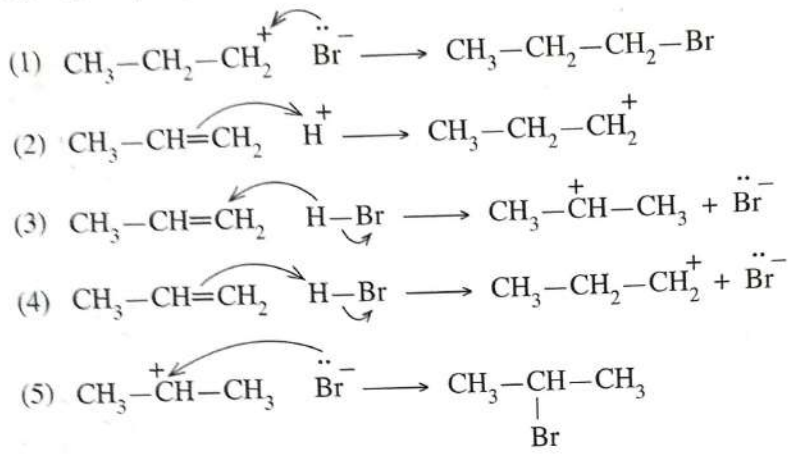

25. නියත උෂ්ණත්වයක ඇති සංවෘත පද්ධතියක සිදුවන වායුමය සමතුලිත ප්‍රතික්‍රියාවක් සලකන්න. පද්ධතියේ පීඩනය හා පරිමාව දෙදුණ කළ විට පද්ධතියේ සමතුලිතතා නියතය,

- (1) හතරෙන් එකක්  $\left(\frac{1}{4}\right)$  වේ.                      (2) බාගයක්  $\left(\frac{1}{2}\right)$  වේ.  
 (3) එලෙසම පවතී.                      (4) දෙදුණ වේ.  
 (5) හතර ගුණයක් වේ.

26. මැග්නීසියම් නයිට්‍රයිඩ් සහ ලිතියම් නයිට්‍රයිඩ් පහත සමීකරණවල ආකාරයට ජලය සමග ප්‍රතික්‍රියා කරයි.

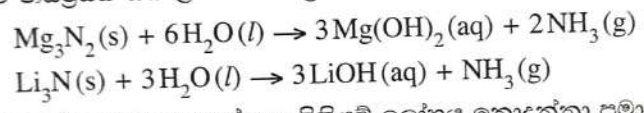

මැග්නීසියම් ලෝහය මවුල තුනක් සහ ලිතියම් ලෝහය නොදන්නා ප්‍රමාණයක් අඩංගු මිශ්‍රණයක් වැඩිපුර  $\text{N}_2$  වායුව සමග සම්පූර්ණයෙන් ප්‍රතික්‍රියා කරවන ලදී. මෙම ප්‍රතික්‍රියාවෙන් ලැබෙන ඵල මිශ්‍රණය සම්පූර්ණයෙන්ම වැඩිපුර ජලය සමග ප්‍රතික්‍රියා කරවූ විට  $\text{NH}_3$  වායුව 44.2 g නිපදවීය. ලෝහ මිශ්‍රණයේ ඇති ලිතියම්වල ස්කන්ධය වන්නේ, (H = 1, Li = 7, N = 14, Mg = 24)

- (1) 1.8 g                      (2) 4.2 g                      (3) 12.6 g                      (4) 14.2 g                      (5) 20.2 g

27. ඇමෝනියා, පහත දැක්වෙන තුලිත නොකරන ලද රසායනික සමීකරණයෙන් පෙන්වා දී ඇති පරිදි, ඉහළ උෂ්ණත්වවලදී සංස්ලේෂණය කළ හැක.

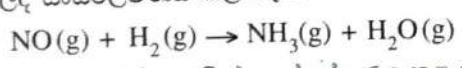

NO 45.0 g සහ  $\text{H}_2$  12.0 g මගින් සංස්ලේෂණය කළ හැකි උපරිම  $\text{NH}_3$  ප්‍රමාණය, ග්‍රෑම්වලින් වනුයේ, (සාපේක්ෂ අණුක ස්කන්ධය:  $\text{H}_2 = 2, \text{NO} = 30, \text{NH}_3 = 17$ )

- (1) 2.4                      (2) 4.8                      (3) 12.8                      (4) 25.5                      (5) 40.8

28. උෂ්ණත්වය 25 °C දී විද්‍යුත් රසායනික කෝෂයක් තුළ සිදුවන  $2\text{H}_2\text{O}_2(\text{aq}) \rightarrow 2\text{H}_2\text{O}(\text{l}) + \text{O}_2(\text{g})$  ප්‍රතික්‍රියාවෙහි  $E_{\text{cell}}^{\circ} + 0.55 \text{ V}$  වන අතර මෙම ක්‍රියාවලියෙහි අර්ධ-ප්‍රතික්‍රියා වන්නේ,

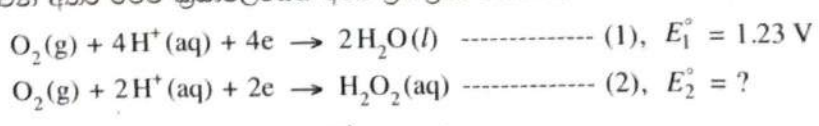

ප්‍රතික්‍රියාව (2) හි සම්මත ඔක්සිහරණ විභවය  $E_2^{\circ}$  වනුයේ,

- (1) -1.78 V                      (2) -0.68 V                      (3) 0.00 V                      (4) +0.68 V                      (5) +1.78 V

29. පහත සඳහන් ප්‍රතික්‍රියාවේ ප්‍රධාන ඵලය විය හැක්කේ කුමක් ද?

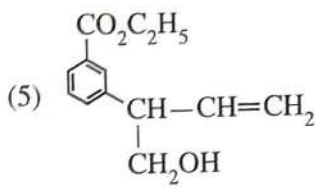
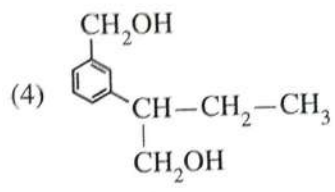
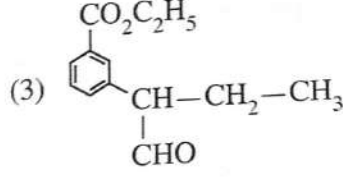
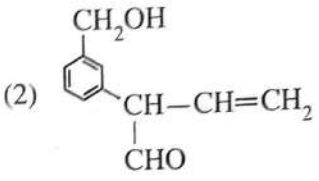
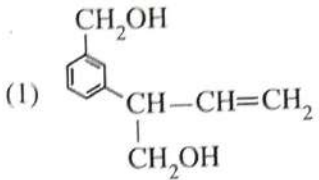
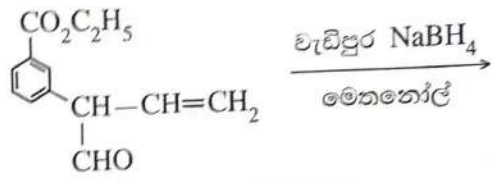

30. උෂ්ණත්වය 25 °C දී සිදුවන  $3O_2(g) \rightleftharpoons 2O_3(g)$ , ( $K_C = 2.0 \times 10^{-56} \text{ mol}^{-1} \text{ dm}^3$ ) ප්‍රතික්‍රියාව සලකන්න.  $O_2(g)$  0.30 mol සහ  $O_3(g)$  0.005 mol 25 °C ඇති රේඛනය කළ දෘඪ සංචාන 1.0 dm<sup>3</sup> බඳුනක් තුළට ඇතුළු කර පද්ධතිය ඉහත සමතුලිතතාවයට එළඹීමට ඉඩ හරින ලදී. පහත සඳහන් කුමක් 25 °C දී මෙම පද්ධතිය සමතුලිතතාවයට ළඟා වීම ඉතාමත් හොඳින් විස්තර කරයි ද? ( $Q_C$  යනු ප්‍රතික්‍රියා ලබ්ධිය වේ.)

- (1)  $Q_C < K_C$  නිසා  $O_3(g)$  ප්‍රමාණය වැඩි වී සමතුලිතතාවයට ළඟා වේ.
- (2)  $Q_C < K_C$  නිසා  $O_3(g)$  ප්‍රමාණය අඩු වී සමතුලිතතාවයට ළඟා වේ.
- (3)  $Q_C > K_C$  නිසා  $O_3(g)$  ප්‍රමාණය අඩු වී සමතුලිතතාවයට ළඟා වේ.
- (4)  $Q_C > K_C$  නිසා  $O_3(g)$  ප්‍රමාණය වැඩි වී සමතුලිතතාවයට ළඟා වේ.
- (5)  $Q_C = K_C$  නිසා  $O_3(g)$  ප්‍රමාණය වෙනස් නොවේ.

• අංක 31 සිට 40 තෙක් එක් එක් ප්‍රශ්නය සඳහා දී ඇති (a), (b), (c) සහ (d) යන ප්‍රතිචාර හතර අතුරෙන්, එකක් හෝ වැඩි සංඛ්‍යාවක් හෝ නිවැරදි ය. නිවැරදි ප්‍රතිචාරය/ප්‍රතිචාර කවරේ දැයි තෝරා ගන්න.

- (a) සහ (b) පමණක් නිවැරදි නම් (1) මත ද
- (b) සහ (c) පමණක් නිවැරදි නම් (2) මත ද
- (c) සහ (d) පමණක් නිවැරදි නම් (3) මත ද
- (d) සහ (a) පමණක් නිවැරදි නම් (4) මත ද
- වෙනත් ප්‍රතිචාර සංඛ්‍යාවක් හෝ සංයෝජනයක් හෝ නිවැරදි නම් (5) මත ද

පිළිතුරු පත්‍රයෙහි දැක්වෙන උපදෙස් පරිදි ලකුණු කරන්න.

**ඉහත උපදෙස් සම්පිණ්ඩනය**

(1)	(2)	(3)	(4)	(5)
(a) සහ (b) පමණක් නිවැරදියි	(b) සහ (c) පමණක් නිවැරදියි	(c) සහ (d) පමණක් නිවැරදියි	(d) සහ (a) පමණක් නිවැරදියි	වෙනත් ප්‍රතිචාර සංඛ්‍යාවක් හෝ සංයෝජනයක් හෝ නිවැරදි යි

31. දී ඇති රසායනික ප්‍රතික්‍රියාවක් සඳහා උෂ්ණත්වය මගින් පහත සඳහන් කුමක්/කුමන ඒවා මත බලපෑමක් ඇති කරන්නේ ද?

- (a) ප්‍රතික්‍රියක අණුවල සංඝට්ටන සංඛ්‍යාතය
- (b) සංඝට්ටනය වන අණුවල වාලක ශක්තිය
- (c) 25 °C දී ප්‍රතික්‍රියාවේ සම්මත එන්තැල්පි වෙනස
- (d) ප්‍රතික්‍රියාවේ සක්‍රියන ශක්තිය

32. පහත දැක්වෙන ප්‍රතික්‍රියාවේ යන්ත්‍රණය සලකන්න.

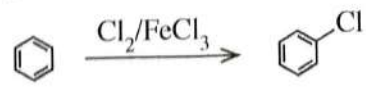

පහත දැක්වෙන අයනවලින් කුමක්/කුමන ඒවා මෙම ප්‍රතික්‍රියාව සිදුවන අතරතුර සෑදේ ද?

- (a)  $FeCl_4^-$
- (b)  $FeCl_4^+$
- (c) [H+]c1ccccc1Cl
- (d) [H+]c1ccccc1

33. 25 °C දී සහ ලෙඩ් අයඩයිඩ් ( $PbI_2$ ) වැඩිපුර ප්‍රමාණයක් සමග සමතුලිතව පවතින ජලීය ලෙඩ් අයඩයිඩ් ද්‍රාවණ  $1.0 \text{ dm}^3$  ක් තුළ  $Pb^{2+}(aq)$  අයන  $a \text{ mol}$  ප්‍රමාණයක් අඩංගු වේ. පහත සඳහන් කුමක්/කුමන ඒවා මෙම පද්ධතිය සඳහා නිවැරදි වේ ද?
- පරිමාව දෙගුණ කළ විට  $Pb^{2+}(aq)$  ප්‍රමාණය  $2a \text{ mol}$  වේ.
  - පරිමාව දෙගුණ කළ විට  $Pb^{2+}(aq)$  සාන්ද්‍රණය  $2a \text{ mol dm}^{-3}$  වේ.
  - සහ  $NaI(s)$  ස්වල්ප ප්‍රමාණයක් එකතු කළ විට  $Pb^{2+}(aq)$  ප්‍රමාණය අඩු වේ.
  - පරිමාව දෙගුණ කළ විට  $Pb^{2+}(aq)$  ප්‍රමාණය  $\frac{a}{2} \text{ mol}$  වේ.
34. හතරවන ආවර්තයට අයත්  $d$  ගොනුවේ මූලද්‍රව්‍ය සාදන සංයෝග/අයන සම්බන්ධව පහත සඳහන් කුමන ප්‍රකාශ/ප්‍රකාශ නිවැරදි වේ ද?
- ප්‍රබල අම්ල සහ ප්‍රබල භස්ම සමග  $Cr_2O_3$  ප්‍රතික්‍රියා කිරීම බලාපොරොත්තු විය හැක.
  - $Fe^{2+}(aq)$ ,  $Fe^{3+}(aq)$ ,  $Mn^{2+}(aq)$  සහ  $Ni^{2+}(aq)$  අඩංගු ද්‍රාවණවලට  $NaOH(aq)$  එකතු කළ විට වැඩිපුර  $NaOH(aq)$  හි අද්‍රාව්‍ය අවස්ථාව සෑදේ.
  - $KMnO_4$  සහ  $K_2Cr_2O_7$  යන දෙකම ආම්ලික තත්ත්ව යටතේදී  $H_2O_2$ ,  $O_2$  වායුවට පරිවර්තනය කිරීමට හැකියාවක් ඇති ප්‍රබල ඔක්සිකාරක වේ.
  - $[CuCl_4]^{2-}$  වල IUPAC නාමය tetrachlorocuprate(II) ion වේ.
35. පහත දී ඇති ප්‍රකාශවලින් කුමක්/කුමන ඒවා නිවැරදි ද?
- ප්‍රොපනොයික් අම්ලයේ තාපාංකය, 1-බියුටනෝල්හි එම අගයට වඩා වැඩි ය.
  - පෙන්ටේන්හි තාපාංකය, 2-මෙතිල්බියුටේන්හි එම අගයට වඩා වැඩි ය.
  - බියුටනෝල්හි තාපාංකය, 1-බියුටනෝල්හි එම අගයට වඩා වැඩි ය.
  - හෙක්සේන්හි තාපාංකය, 1-පෙන්ටනෝල්හි එම අගයට වඩා වැඩි ය.
36. නයිට්‍රික් අම්ලය ( $HNO_3$ ) සහ එහි ලවණ සම්බන්ධව පහත සඳහන් කුමන ප්‍රකාශ/ප්‍රකාශ නිවැරදි වේ ද?
- තනුක සහ සාන්ද්‍ර  $HNO_3$  යන දෙකම ඔක්සිකාරක ලෙස හැසිරේ.
  - $NH_4NO_3$  තාප විභ්වයෙන්  $N_2O$  සහ ජලය ලබා දේ.
  - $HNO_3$  වල N—O බන්ධන සියල්ලම දිගින් සමාන ය.
  - රත් කළ විටදී වුවද කාබන්, සාන්ද්‍ර  $HNO_3$  සමග ප්‍රතික්‍රියා නොකරයි.
37. ඕසෝන් ස්ථරය සම්බන්ධයෙන් පහත සඳහන් කුමන ප්‍රකාශ/ප්‍රකාශ නිවැරදි වේ ද?
- එය ඉහළ වායුගෝලයේ (ස්ථර ගෝලය) ඕසෝන් පමණක් ඇති ප්‍රදේශයකි.
  - එය වායුගෝලයේ පරමාණුක ඔක්සිජන් බහුලව පවතින ප්‍රදේශයකි.
  - එය සූර්යාගෙන් මුක්තවන පාරජම්බුල කිරණ පෘථිවි පෘෂ්ඨය කරා ළඟාවීම වළක්වන ප්‍රදේශයකි.
  - එය ඕසෝන් බිඳවැටීම ක්ලෝරින් මුක්ත බන්ධක යන්ත්‍රණයක් හරහා පමණක් සිදුවන ප්‍රදේශයකි.
38. උෂ්ණත්වය 25 °C දී වසන ලද බෝතලයක් තුළ  $0.135 \text{ mol dm}^{-3}$  මීතයිල් ඇමීන් ( $CH_3NH_2$ ) ජලීය ද්‍රාවණ  $100.00 \text{ cm}^3$  ක පරිමාවක් ජලය සමග මිශ්‍ර නොවන කාබනික ද්‍රාවක  $75.00 \text{ cm}^3$  ක් සමග හොඳින් සොලවා සමතුලිතතාවයට එළඹීමට ඉඩහරින ලදී. ජලීය ස්ථරයෙන්  $50.00 \text{ cm}^3$  ක් ගෙන  $0.200 \text{ mol dm}^{-3}$   $HCl$  ද්‍රාවණයක් සමග අනුමාපනය කල විට අන්ත ලක්ෂ්‍යය  $15.00 \text{ cm}^3$  විය. මීතයිල් ඇමීන් සහ කාබනික ද්‍රාවකය අතර ප්‍රතික්‍රියාවක් සිදු නොවේ. පහත සඳහන් කුමක්/කුමන ඒවා නිවැරදි ද?
- කාබනික සහ ජලීය ස්ථර අතර  $CH_3NH_2$  හි ව්‍යාප්ති සංගුණකය  $K_D$  1.67 වේ.
  - කාබනික සහ ජලීය ස්ථර අතර  $CH_3NH_2$  හි ව්‍යාප්ති සංගුණකය  $K_D$  4.67 වේ.
  - ජලීය ස්ථරය තුළ  $CH_3NH_2$  වැඩිපුර ද්‍රවණය වේ.
  - කාබනික ස්ථරය තුළ  $CH_3NH_2$  වැඩිපුර ද්‍රවණය වේ.
39. ජලාගවල ජලයේ ඇති ද්‍රාවිත ඔක්සිජන් මට්ටම සම්බන්ධයෙන් පහත සඳහන් කුමන ප්‍රකාශ/ප්‍රකාශ නිවැරදි වේ ද?
- ජලයේ ද්‍රාවිත ඔක්සිජන්හි සංයුතිය වායුගෝලීය ඔක්සිජන්හි සංයුතියම වෙයි.
  - සුපෝෂණය හේතුවෙන් ජලයේ ද්‍රාවිත ඔක්සිජන් මට්ටම පහළ යයි.
  - ජලයේ ද්‍රාවිත ඔක්සිජන් මට්ටම වැඩි වීම ජලයේ  $H_2S$  නිපදවිය හැක.
  - ප්‍රභාසංස්ලේෂණය හරහා ජලජ ශාක ජලයේ ද්‍රාවිත ඔක්සිජන් මට්ටමට දායකත්වයක් දක්වයි.

40. දී ඇති කාර්මික ක්‍රියාවලි හා සම්බන්ධව පහත දැක්වෙන කුමන ප්‍රකාශය/ප්‍රකාශ නිවැරදි වේ ද?
- (a) ධාරා උෂ්මකයක් මගින් යකඩ නිස්සාරණයේදී භාවිත වන අමුද්‍රව්‍යයක් වන කෝක්, ඔක්සිහාරකයක් ලෙස පමණක් ක්‍රියා කරයි.
  - (b) මැග්නීසියම් නිස්සාරණයේදී (Dow ක්‍රියාවලිය) භාවිත වන අමුද්‍රව්‍යයක්, විද්‍යුත් විච්ඡේදන පියවරේදී සෑදෙන අතුරුඵලයක් යොදාගනිමින් පුනර්ජනනය කළ හැක.
  - (c) රූටයිල් භාවිත කරමින් සංඥාදායකයෙන් ඉහළ  $TiO_2$  නිෂ්පාදනයේදී, ක්ලෝරිනීකරණ පියවරේදී අකාබනික අපද්‍රව්‍ය ඉවත් වෙයි.
  - (d) ඔස්ට්‍රේඩ් ක්‍රමය භාවිතයෙන් නයිට්‍රික් අම්ලය නිෂ්පාදනයේදී උත්ප්‍රේරකය ලෙස Fe භාවිත වේ.
- අංක 41 සිට 50 තෙක් එක් එක් ප්‍රශ්නය සඳහා ප්‍රකාශ දෙක බැගින් ඉදිරිපත් කර ඇත. එම ප්‍රකාශ යුගලයට හොඳින්ම ගැලපෙනුයේ පහත වගුවෙහි දැක්වෙන පරිදි (1), (2), (3), (4) සහ (5) යන ප්‍රතිචාරවලින් කවර ප්‍රතිචාරය දැයි තෝරා පිළිතුරු පත්‍රයෙහි උචිත ලෙස ලකුණු කරන්න.

ප්‍රතිචාරය	පළමුවැනි ප්‍රකාශය	දෙවැනි ප්‍රකාශය
(1)	සත්‍ය වේ.	සත්‍ය වන අතර, පළමුවැනි ප්‍රකාශය නිවැරදිව පහදා දෙයි.
(2)	සත්‍ය වේ.	සත්‍ය වන නමුත් පළමුවැනි ප්‍රකාශය නිවැරදිව පහදා නොදෙයි.
(3)	සත්‍ය වේ.	අසත්‍ය වේ.
(4)	අසත්‍ය වේ.	සත්‍ය වේ.
(5)	අසත්‍ය වේ.	අසත්‍ය වේ.

පළමුවැනි ප්‍රකාශය	දෙවැනි ප්‍රකාශය
41. ක්ලෝරිනි ඔක්සෝ අම්ලවල ආම්ලිකතාවයන් අඩු වන අනුපිළිවෙළ වනුයේ $HClO_4 > HClO_3 > HClO_2 > HOCl$	ක්ලෝරිනි ඔක්සෝ අම්ලවල ක්ලෝරිනි පරමාණුවේ ඔක්සිකරණ අංකය වැඩි වන විට ඔක්සෝ අම්ලයෙහි ආම්ලිකතාවය වැඩි වේ.
42. $H_2S$ වායුව ආම්ලික $K_2Cr_2O_7$ ද්‍රාවණයක් සමග ප්‍රතික්‍රියා කළ විට මූලද්‍රව්‍යමය සල්ෆර් සෑදේ.	ආම්ලික මාධ්‍යයේදී $H_2S$ වායුවට ඔක්සිහාරකයක් ලෙස හැසිරිය හැක.
43. $Cl_2(g) + 2I^-(aq) \rightarrow 2Cl^-(aq) + I_2(s)$ ප්‍රතික්‍රියාව මත පදනම් වන විද්‍යුත් රසායන කෝෂය විද්‍යුතය නිපදවීමට භාවිත කළ හැක.	$Cl_2(g)$ , $I_2(s)$ වලට වඩා ප්‍රබල ඔක්සිහාරකයකි.
44. ශ්‍රිතාච්ච ප්‍රතිකාරක ජලය සමග ප්‍රතික්‍රියා කර ඇල්කොහොල ලබාදෙයි.	ශ්‍රිතාච්ච ප්‍රතිකාරකයක ඇති කාබන්-මැග්නීසියම් බන්ධනයේ කාබන් පරමාණුවට භාගික සෘණ ආරෝපණයක් ඇත.
45. ඇනලීන්වලින් සෑදෙන ඩයසෝනියම් ලවණ අඩු උෂ්ණත්වවලදී ( $0-5^\circ C$ ) ස්ථායී වන අතර ප්‍රාථමික ඇලිෆැටික ඇමීන්වලින් සෑදෙන ඩයසෝනියම් ලවණ මෙම උෂ්ණත්වවලදී අස්ථායී වේ.	ඇනලීන් හි නයිට්‍රජන් පරමාණුව මත ඇති එකසර ඉලෙක්ට්‍රෝන යුගලය බෙන්සීන් වලය මත විස්ථානගත වී ඇත.
46. දී ඇති උෂ්ණත්වයකදී සම්පූර්ණයෙන් මිශ්‍රවන ද්‍රව දෙකකින් පරිපූර්ණ ද්‍රවයෙහි මිශ්‍රණයක් සෑදීමේදී ඇතිවන එන්තැල්පි වෙනස ශුන්‍ය වේ.	දී ඇති උෂ්ණත්වයකදී, පරිපූර්ණ ද්‍රවයෙහි ද්‍රව මිශ්‍රණයක පවතින සියලුම අන්තර්-අණුක බල සමාන වේ.
47. වර්ෂා ජලයේ pH අගය 6.5 ලෙස වාර්තා වූ විට එය අම්ල වැසි ලෙස සැලකේ.	වර්ෂා ජලයේ pH අගය 7 ට අඩු වීම $SO_3$ සහ $NO_2$ ආම්ලික වායූන් ද්‍රවණය වීම නිසා පමණක් සිදුවෙයි.
48. දී ඇති උෂ්ණත්වයකදී පළමු පෙළ ප්‍රතික්‍රියාවක අර්ධජීව කාලය $t_{1/2} = 0.693/k$ යන සමීකරණයෙන් ලබාදෙන අතර $k$ යනු පළමු පෙළ වේග නියතය වේ.	$t_{1/2} = 50$ s වන පළමු පෙළ ප්‍රතික්‍රියාවක 150 s කට පසු ප්‍රතික්‍රියාවේ 87.5% සම්පූර්ණ වේ.
49. හේබර්-බොෂ් ක්‍රමය මගින් $NH_3$ වායුව නිෂ්පාදනයේදී $600^\circ C$ ට වඩා ඉහළ උෂ්ණත්ව යොදාගනී.	හේබර්-බොෂ් ක්‍රමයෙන් $NH_3$ වායුව ලබාදෙන සමතුලිත ප්‍රතික්‍රියාවේ සක්‍රියන ශක්තිය උෂ්ණත්වය ඉහළ යාමේදී අඩුවේ.
50. බේක්ලයිට් ආකලන බහුඅවයවකයක් ලෙස වර්ගීකරණය කරනු ලැබේ.	බේක්ලයිට්වලට ත්‍රිමාන ජාල ව්‍යුහයක් ඇත.

\*\*\*

[තවමැති පිටුව බලන්න.



# BioApi.Lk

Free Papers and Other Study materials



ශ්‍රී ලංකාවේ විශාලතම  
අධ්‍යාපනික  
සමාජමාධ්‍ය ජාලය



@BioApiSL  
328,000+ Subs



@Biologyapi  
122,000+ Followers



Advertise with BioApi  
070 216 0737



සියලු ම හිමිකම් ඇවිරිණි / முழுப் பதிப்புரிமையுடையது / All Rights Reserved

නව නිර්දේශය/புதிய பாடத்திட்டம் / New Syllabus

ශ්‍රී ලංකා විභාග දෙපාර්තමේන්තුව ශ්‍රී ලංකා විභාග දෙපාර්තමේන්තුව ශ්‍රී ලංකා විභාග දෙපාර්තමේන්තුව ශ්‍රී ලංකා විභාග දෙපාර්තමේන්තුව ශ්‍රී ලංකා විභාග දෙපාර්තමේන්තුව  
 திணைக்களம் இலங்கைப் பரீட்சைத் திணைக்களம் இலங்கைப் பரීட்சைத் திணைக்களம் இலங்கைப் பரීட்சைத் திணைக்களம் இலங்கைப் பரීட்சைத் திணைக்களம்  
 Department of Examinations, Sri Lanka Department of Examinations, Sri Lanka Department of Examinations, Sri Lanka Department of Examinations, Sri Lanka Department of Examinations, Sri Lanka  
 இலங்கைப் பரීட்சைத் திணைக்களம் இலங்கைப் பரීட்சைத் திணைக்களம் இலங்கைப் பரීட்சைத் திணைக்களம் இலங்கைப் பரීட்சைத் திணைக்களம் இலங்கைப் பரීட்சைத் திணைக்களம்  
 Department of Examinations, Sri Lanka

**NEW**

අධ්‍යයන පොදු සහතික පත්‍ර (උසස් පෙළ) විභාගය, 2020  
 கல்விப் பொதுத் தராதரப் பத்திர (உயர் தர)ப் பரீட்சை, 2020  
 General Certificate of Education (Adv. Level) Examination, 2020

රසායන විද්‍යාව II  
 இரசாயனவியல் II  
**Chemistry II**

**02 E II**

පැය තුනයි  
 மூன்று மணித்தியாலம்  
**Three hours**

අමතර කියවීමේ කාලය - මිනිත්තු 10 යි  
 மேலதிக வாசிப்பு நேரம் - 10 நிமிடங்கள்  
**Additional Reading Time - 10 minutes**

Use **additional reading time** to go through the question paper, select the questions and decide on the questions that you give priority in answering.

Index No. : .....

- \* A Periodic Table is provided on page 15.
- \* Use of calculators is not allowed.
- \* Universal gas constant,  $R = 8.314 \text{ J K}^{-1} \text{ mol}^{-1}$
- \* Avogadro constant,  $N_A = 6.022 \times 10^{23} \text{ mol}^{-1}$
- \* In answering this paper, you may represent alkyl groups in a condensed manner.

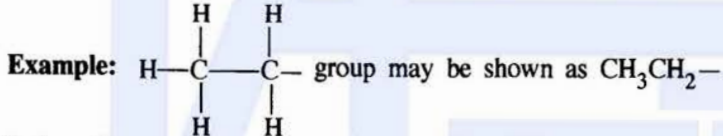

**PART A – Structured Essay (pages 02 - 08)**

- \* Answer **all** the questions on the question paper itself.
- \* Write your answer in the space provided for each question. Please note that the space provided is sufficient for the answer and that extensive answers are not expected.

**PART B and PART C – Essay (pages 09 - 14)**

- \* Answer **four** questions selecting **two** questions from each part. Use the papers supplied for this purpose.
- \* At the end of the time allotted for this paper, tie the answers to the three Parts A, B and C together so that Part A is on top and hand them over to the Supervisor.
- \* You are permitted to remove **only** Parts B and C of the question paper from the Examination Hall.

**For Examiner's Use Only**

Part	Question No.	Marks
A	1	
	2	
	3	
	4	
B	5	
	6	
	7	
C	8	
	9	
	10	
<b>Total</b>		

Total	
In Numbers	
In Letters	

Code Numbers	
Marking Examiner 1	
Marking Examiner 2	
Checked by :	
Supervised by :	

## PART A – STRUCTURED ESSAY

Answer **all four** questions on this paper itself. (Each question carries **100** marks.)Do not  
write  
in this  
column.

1. (a) Write the answers to the questions given below on the dotted lines.

- (i) Of the three ions  $\text{Na}^+$ ,  $\text{Mg}^{2+}$  and  $\text{F}^-$ , which one has the **smallest** ionic radius? .....
- (ii) Of the three elements C, N and O, which one has the **highest** second ionization energy? .....
- (iii) Of the three compounds  $\text{H}_2\text{O}$ ,  $\text{HOCl}$  and  $\text{OF}_2$ , which one has the **most** electronegative oxygen atom? .....
- (iv) Of the three elements Be, C and N, which one will liberate energy when an electron is added to its atom [ $\text{Y}(\text{g}) + \text{e} \rightarrow \text{Y}^-(\text{g})$ ;  $\text{Y} = \text{Be}, \text{C}, \text{N}$ ] in the gaseous state? .....
- (v) Of the three ionic compounds NaF, KF and KBr, which one has the **highest** solubility in water? .....
- (vi) Of the three compounds HCHO,  $\text{CH}_3\text{F}$  and  $\text{H}_2\text{O}_2$ , which one has the **strongest** intermolecular forces? .....

(24 marks)

(b) (i) Draw the **most** acceptable Lewis dot-dash structure for the ion,  $\text{N}_2\text{O}_3^{2-}$ . Its skeleton is given below.(ii) Draw **three** more Lewis dot-dash structures (resonance structures) for this ion. Indicate the relative stabilities of the structures drawn by you, when compared with the most acceptable structure drawn in (i) above, by writing 'less stable' or 'unstable' under these structures.

(iii) Complete the given table based on the Lewis dot-dash structure and its labelled skeleton given below.

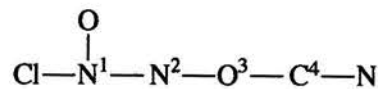
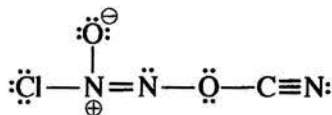

	$\text{N}^1$	$\text{N}^2$	$\text{O}^3$	$\text{C}^4$
VSEPR pairs around the atom				
electron pair geometry around the atom				
shape around the atom				
hybridization of the atom				

[see page three

Do not  
write  
in this  
column.

- Parts (iv) to (vii) are based on the Lewis dot-dash structure given in part (iii) above. Labelling of atoms is as in part (iii).

(iv) Identify the atomic / hybrid orbitals involved in the formation of  $\sigma$  bonds between the two atoms given below.

- |                                     |                      |                      |
|-------------------------------------|----------------------|----------------------|
| I. Cl—N <sup>1</sup>                | Cl .....             | N <sup>1</sup> ..... |
| II. N <sup>1</sup> —O               | N <sup>1</sup> ..... | O .....              |
| III. N <sup>1</sup> —N <sup>2</sup> | N <sup>1</sup> ..... | N <sup>2</sup> ..... |
| IV. N <sup>2</sup> —O <sup>3</sup>  | N <sup>2</sup> ..... | O <sup>3</sup> ..... |
| V. O <sup>3</sup> —C <sup>4</sup>   | O <sup>3</sup> ..... | C <sup>4</sup> ..... |
| VI. C <sup>4</sup> —N               | C <sup>4</sup> ..... | N .....              |

(v) Identify the atomic orbitals involved in the formation of  $\pi$  bonds between the two atoms given below.

- |                                   |                      |                      |
|-----------------------------------|----------------------|----------------------|
| I. N <sup>1</sup> —N <sup>2</sup> | N <sup>1</sup> ..... | N <sup>2</sup> ..... |
| II. C <sup>4</sup> —N             | C <sup>4</sup> ..... | N .....              |
|                                   | C <sup>4</sup> ..... | N .....              |

(vi) State the approximate bond angles around N<sup>1</sup>, N<sup>2</sup>, O<sup>3</sup> and C<sup>4</sup> atoms.

N<sup>1</sup> ....., N<sup>2</sup> ....., O<sup>3</sup> ....., C<sup>4</sup> .....

(vii) Arrange the atoms N<sup>1</sup>, N<sup>2</sup>, O<sup>3</sup> and C<sup>4</sup> in the **increasing** order of electronegativity.

..... < ..... < ..... < ..... (56 marks)

(c) Consider the following information.

- I. The atoms **A** and **B** combine to form a heterodiatomic molecule **AB** that has a  $\sigma$  bond. This is represented as **A—B**.
- II. The electronegativity of **A** is less than that of **B** ( $X_A < X_B$ ).  
X = electronegativity of the atom
- III. The inter-nuclear distance between **A** and **B** atoms ( $d_{A-B}$ ) of the **AB** molecule is given by the following equation.

$$d_{A-B} = r_A + r_B - c(X_B - X_A)$$

r = atomic radius, c = 9 pm

**Note:** d and r are measured in picometres (pm). (1 pm = 10<sup>-12</sup> m)

Based on the above information, answer the following questions.

- (i) What is the name used to identify the type of  $\sigma$  bond between **A** and **B**?  
.....
- (ii) Show how fractional charges ( $\delta+$  and  $\delta-$ ) are located in the molecule **AB**.  
.....
- (iii) Write the equation to calculate the dipole moment ( $\mu$ ) of molecule **AB** and show its direction.

[see page four

- (iv) Calculate the percentage of ionic character of the H-F bond in the HF molecule using the data given below.

Inter-nuclear distance of  $H_2$  ( $d_{H-H}$ ) = 74 pm

Electronegativity of F = 4.0

Inter-nuclear distance of  $F_2$  ( $d_{F-F}$ ) = 144 pm

Dipole moment of HF =  $6.0 \times 10^{-30}$  C m

Electronegativity of H = 2.1

Charge of an electron =  $1.6 \times 10^{-19}$  C

Do not write in this column.

100

(20 marks)

2. (a) A, B, C and D are chlorides of *p*-block elements. These elements have atomic numbers less than 20. A description of the products ( $P_1 - P_9$ ) formed when A is reacted with a limited amount of water and B, C and D are reacted with excess water are given below.

Compound	Description of products
A	$P_1$ a compound with a covalent network structure
	$P_2$ a strong monobasic acid
B	$P_3$ a gas that turns red litmus blue
	$P_4$ a compound with bleaching properties
C	$P_5$ a tribasic acid
	$P_6$ a strong monobasic acid
D	$P_7$ a gas that turns acidic $KMnO_4$ solution colourless
	$P_8$ a colloidal solid
	$P_9$ a strong monobasic acid

- (i) Identify A, B, C and D (give the chemical formulae).

A: ..... B: ..... C: ..... D: .....

- (ii) Give balanced chemical equations for the reactions of A, B, C and D with water to give products  $P_1$  to  $P_9$ .

.....

.....

.....

.....

[see page five]

Do not  
write  
in this  
column.

(iii) Write balanced chemical equations for the following reactions.

I.  $P_1$  with  $\text{NaOH(aq)}$ 

.....

II.  $P_3$  with  $\text{Mg}$ 

.....

III.  $P_7$  with acidic  $\text{K}_2\text{Cr}_2\text{O}_7$ 

.....

(50 marks)

(b) A student is provided with bottles labelled **P, Q, R, S, T** and **U** containing aqueous solutions of  $\text{Al}_2(\text{SO}_4)_3$ ,  $\text{H}_2\text{SO}_4$ ,  $\text{Na}_2\text{S}_2\text{O}_3$ ,  $\text{BaCl}_2$ ,  $\text{Pb}(\text{Ac})_2$  and  $\text{KOH}$  (not in order). Some useful observations for their identification on mixing two solutions at a time are given below.

(Ac - Acetate ion)

	Solutions mixed	Observations
<b>I</b>	<b>T + R</b>	a clear colourless solution
<b>II</b>	<b>P + R</b>	a white precipitate
<b>III</b>	<b>T + S</b>	a gelatinous white precipitate
<b>IV</b>	<b>U + R</b>	a white precipitate
<b>V</b>	<b>P + Q</b>	a white precipitate, turns black on heating
<b>VI</b>	<b>P + U</b>	a white precipitate, dissolves on heating

(i) Identify **P** to **U**.**P:** ..... **Q:** ..... **R:** .....**S:** ..... **T:** ..... **U:** .....(ii) Give balanced chemical equations for each of the reactions **I** to **VI**.**I:** .....**II:** .....**III:** .....**IV:** .....**V:** formation of white precipitate: .....

turning black on heating: .....

**VI:** .....

(Note: indicate precipitates as ↓)

(50 marks)

3. (a) A saturated aqueous solution of a sparingly soluble salt  $\text{AB}_2(\text{s})$  was prepared by stirring an excess amount of  $\text{AB}_2(\text{s})$  in  $1.0 \text{ dm}^3$  of distilled water at  $25^\circ\text{C}$ . The amount of  $\text{A}^{2+}(\text{aq})$  ions present in this saturated aqueous solution was found to be  $2.0 \times 10^{-3} \text{ mol}$ .

(i) Write the equilibrium related to the dissolution of  $\text{AB}_2(\text{s})$  in the above system at  $25^\circ\text{C}$ .

.....

(ii) Write the expression for the equilibrium constant for the equilibrium written in (i) above at  $25^\circ\text{C}$ .

.....

.....

100

[see page six

Do not write in this column.

(iii) Calculate the value of the equilibrium constant stated in (ii) above at 25 °C.

.....

.....

.....

.....

.....

(iv) Another saturated aqueous solution of AB<sub>2</sub> was prepared by stirring an excess amount of AB<sub>2</sub>(s) in 2.0 dm<sup>3</sup> of distilled water at 25 °C. Giving reasons, predict the value of the equilibrium constant for this system.

.....

.....

(v) A small amount of the strong electrolyte NaB(s) is added to a saturated aqueous solution of AB<sub>2</sub> at 25 °C. Giving reasons, predict whether the concentration of A<sup>2+</sup>(aq) is increased or decreased.

.....

.....

.....

(60 marks)

(b) In an aqueous solution, propanoic acid (C<sub>2</sub>H<sub>5</sub>COOH) ionizes as given below.

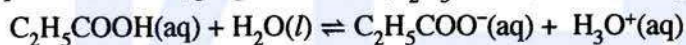

At 25 °C,  $K_a$  (propanoic acid) =  $1.0 \times 10^{-5}$

(i) Write the expression for the equilibrium constant for the above reaction at 25 °C.

.....

.....

(ii) 100.0 cm<sup>3</sup> of an aqueous solution of C<sub>2</sub>H<sub>5</sub>COOH(aq) was prepared by dissolving 0.74 cm<sup>3</sup> of C<sub>2</sub>H<sub>5</sub>COOH in distilled water at 25 °C. Calculate the pH of the solution at 25 °C. (C = 12; O = 16; H = 1; consider the density of C<sub>2</sub>H<sub>5</sub>COOH as 1.0 g cm<sup>-3</sup>)

(40 marks)

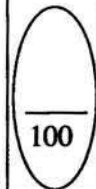

[see page seven

Do not  
write  
in this  
column.

4. (a) **A, B, C** and **D** are structural isomers having the molecular formula  $C_6H_{10}$ . None of them show optical isomerism. All four isomers, **A, B, C** and **D** when treated with  $HgSO_4/dil. H_2SO_4$  give products which react with 2,4-dinitrophenylhydrazine (2,4-DNP) to give coloured precipitates. Only **A** gives a precipitate with ammonical  $AgNO_3$ . **A** has only one position isomer, which is **B**. **B** is a chain isomer of **C**. **C** reacts with  $HgSO_4/dil. H_2SO_4$  to give two products **E** and **F**. **D** reacts with  $HgSO_4/dil. H_2SO_4$  to give only one product, which is **E**.

(i) Draw the structures of **A, B, C, D, E** and **F** in the boxes given below.

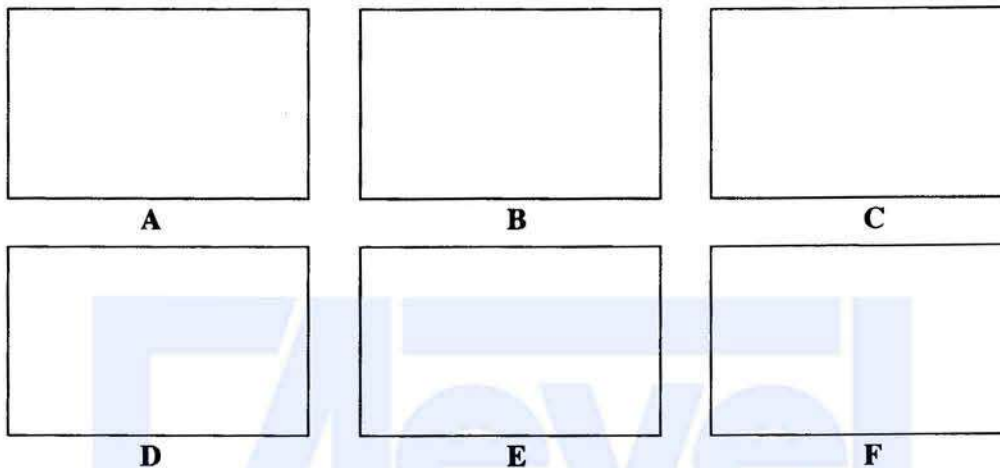

- (ii) Which of the compounds **A, B, C** and **D** gives a product that does not show diastereoisomerism when reacted separately with  $H_2 / Pd-BaSO_4 / quinoline$ ?

- (iii) Draw, in the box given below, the structure of the product **G** obtained when **A** is reacted with excess  $HBr$ .

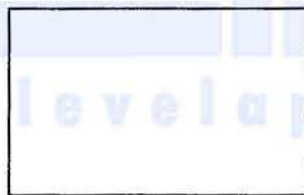
**G**

- (iv) Draw the structures of products **X** and **Y** obtained in the following reactions of **E**, in the appropriate boxes.

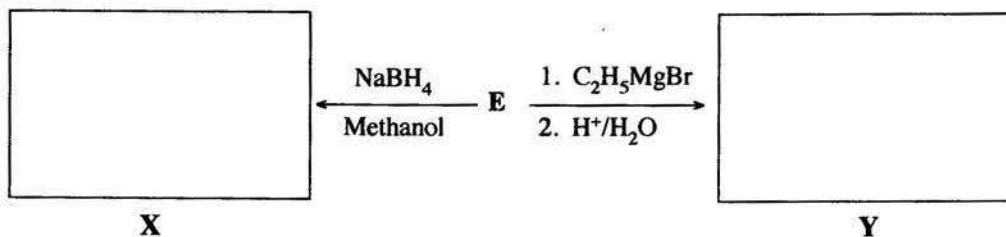

Name a test to distinguish between **X** and **Y**.

.....

(60 marks)

[see page eight



Do not write in this column.

(b) (i) Complete the following three reaction sequences by drawing structures of compounds **K**, **L** and **M** and giving the reagents/catalysts **P**, **Q** and **R** in the boxes given below.

Sequence 1:

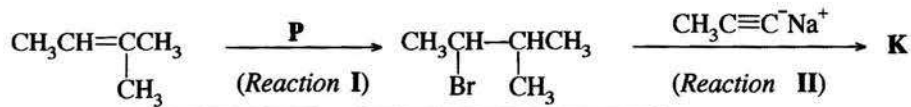

**P**

**K**

Sequence 2:

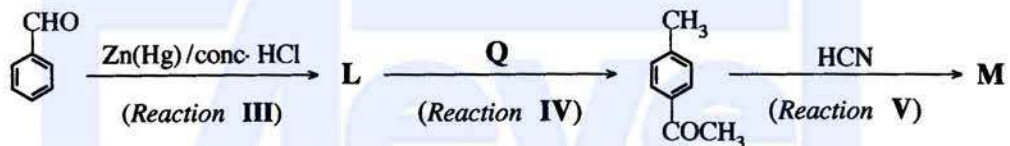

**L**

**Q**

**M**

Sequence 3:

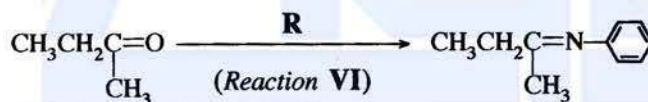

**R**

(30 marks)

(ii) Selecting from the reactions I–VI, give one (01) example for each of the following types of reactions.

Nucleophilic addition .....

Nucleophilic substitution .....

(10 marks)

\* \*

100

[see page nine

## නව නිර්දේශය/புதிய பாடத்திட்டம் / New Syllabus

 ශ්‍රී ලංකා විභාග දෙපාර්තමේන්තුව ශ්‍රී ලංකා විභාග දෙපාර්තමේන්තුව ශ්‍රී ලංකා විභාග දෙපාර්තමේන්තුව ශ්‍රී ලංකා විභාග දෙපාර්තමේන්තුව ශ්‍රී ලංකා විභාග දෙපාර්තමේන්තුව  
 திணைக்களம் இலங்கைப் பரீட்சைத் திணைக்களம் இலங்கைப் பரීட்சைத் திணைக்களம் இலங்கைப் பரීட்சைத் திணைக்களம் இலங்கைப் பரීட்சைத் திணைக்களம்  
 Department of Examinations, Sri Lanka Department of Examinations, Sri Lanka Department of Examinations, Sri Lanka Department of Examinations, Sri Lanka Department of Examinations, Sri Lanka

අධ්‍යයන පොදු සහතික පත්‍ර (උසස් පෙළ) විභාගය, 2020  
 கல்விப் பொதுத் தராதரப் பத்திர (உயர் தர)ப் பரீட்சை, 2020  
 General Certificate of Education (Adv. Level) Examination, 2020

රසායන විද්‍යාව II  
 இரசாயனவியல் II  
 Chemistry II

02 E II

\* Universal gas constant  $R = 8.314 \text{ J K}^{-1} \text{ mol}^{-1}$

\* Avogadro constant  $N_A = 6.022 \times 10^{23} \text{ mol}^{-1}$

## PART B – ESSAY

Answer two questions only. (Each question carries 150 marks.)

5. (a) A compound  $\text{XY}_2\text{Z}_2(\text{g})$  undergoes dissociation when heated to temperatures above 300 K as given below.

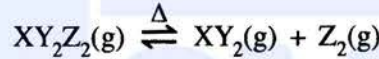

A sample of 7.5 g of  $\text{XY}_2\text{Z}_2(\text{g})$  was placed in an evacuated 1.00 dm<sup>3</sup> rigid-closed container and the temperature was raised to 480 K.

Molar mass of  $\text{XY}_2\text{Z}_2(\text{g})$  is 150 g mol<sup>-1</sup>. Use the approximate value of 4000 J mol<sup>-1</sup> for  $RT$  at 480 K. Assume ideal gas behaviour for all gases.

- Calculate the number of moles of  $\text{XY}_2\text{Z}_2(\text{g})$  in the container before dissociation.
  - When the above system reaches equilibrium at 480 K, the total number of moles in the container was found to be  $7.5 \times 10^{-2}$  mol. Calculate the number of moles of  $\text{XY}_2\text{Z}_2(\text{g})$ ,  $\text{XY}_2(\text{g})$  and  $\text{Z}_2(\text{g})$  in the equilibrium mixture at 480 K.
  - Calculate the equilibrium constant  $K_c$  for the above reaction at 480 K.
  - Calculate  $K_p$  for the equilibrium at 480 K. (75 marks)
- (b) For the reaction  $\text{XY}_2\text{Z}_2(\text{g}) \rightarrow \text{XY}_2(\text{g}) + \text{Z}_2(\text{g})$  described in (a), Gibbs free energies ( $G$ ) at 480 K for  $\text{XY}_2\text{Z}_2(\text{g})$ ,  $\text{XY}_2(\text{g})$  and  $\text{Z}_2(\text{g})$  are  $-60 \text{ kJ mol}^{-1}$ ,  $-76 \text{ kJ mol}^{-1}$  and  $-30 \text{ kJ mol}^{-1}$ , respectively.

- Calculate  $\Delta G$  (in kJ mol<sup>-1</sup>) for the reaction at 480 K.
- The magnitude of  $\Delta S$  of the above reaction is  $150 \text{ J K}^{-1} \text{ mol}^{-1}$  at 480 K. Calculate  $\Delta H$  for the reaction at 480 K by using the appropriate sign (- or +) of  $\Delta S$ .
- By using the sign (- or +) of  $\Delta H$  obtained in (ii), explain whether this reaction is exothermic or endothermic.
- Deduce the enthalpy difference for the formation of  $\text{XY}_2\text{Z}_2(\text{g})$  from  $\text{XY}_2(\text{g})$  and  $\text{Z}_2(\text{g})$  at 480 K.

- If the bond enthalpy of the X-Z bond in  $\text{XY}_2\text{Z}_2(\text{g})$  is  $+250 \text{ kJ mol}^{-1}$ , calculate the bond enthalpy of the Z-Z bond.

(Assume that  $\text{XY}_2\text{Z}_2(\text{g})$  has the structure  $\text{Z}-\text{X}-\text{Z}$ )

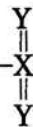

- If liquid  $\text{XY}_2\text{Z}_2$  is used instead of gaseous  $\text{XY}_2\text{Z}_2$ , giving reasons, explain whether the value of  $\Delta H$  obtained for the reaction  $\text{XY}_2\text{Z}_2(\text{l}) \rightarrow \text{XY}_2(\text{g}) + \text{Z}_2(\text{g})$  is equal to, or higher or lower than  $\Delta H$  obtained in (ii). (75 marks)

[see page ten

6. (a) Consider the reaction given below occurring in a closed container at a given temperature  $T$ .



- (i) Write **three** expressions for the rate of reaction relevant to each of the compounds appearing in the reaction.
- (ii) This reaction was carried out at temperature  $T$  with an initial concentration of  $0.10 \text{ mol dm}^{-3}$  of  $\text{N}_2\text{O}_5(\text{g})$ . It was found that 40% of the initial amount was decomposed after a period of 400 s.
- Calculate the average rate of decomposition of  $\text{N}_2\text{O}_5(\text{g})$  in this time interval.
  - Calculate average rates of formation of  $\text{NO}_2(\text{g})$  and  $\text{O}_2(\text{g})$ .
- (iii) In another experiment, initial rates were measured for this reaction at 300 K and the results are given below.

$[\text{N}_2\text{O}_5(\text{g})] / \text{mol dm}^{-3}$	0.01	0.02	0.03
Initial rate / $\text{mol dm}^{-3} \text{ s}^{-1}$	$6.930 \times 10^{-5}$	$1.386 \times 10^{-4}$	$2.079 \times 10^{-4}$

Derive the rate law for the reaction at 300 K.

- (iv) Another experiment was carried out at 300 K with an initial concentration of  $0.64 \text{ mol dm}^{-3}$  of  $\text{N}_2\text{O}_5(\text{g})$ . It was found that the concentration of  $\text{N}_2\text{O}_5(\text{g})$  which remained after a period of 500 s was  $2.0 \times 10^{-2} \text{ mol dm}^{-3}$ .
- Calculate the half-life ( $t_{1/2}$ ) of the reaction at 300 K.
  - Calculate the rate constant of the reaction at 300 K.
- (v) This reaction proceeds through a mechanism involving the following elementary steps.

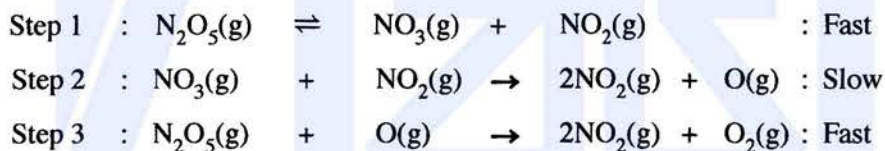

Show that the above mechanism is consistent with the rate law of the reaction. (80 marks)

(b) An ideal binary-liquid mixture was prepared by mixing two liquids of A and B in a closed evacuated container at temperature  $T$ . After establishing the equilibrium at temperature  $T$ , partial pressures of A and B in the vapour phase are  $P_A$  and  $P_B$ , respectively. At temperature  $T$ , the saturated vapour pressures of A and B are  $P_A^\circ$  and  $P_B^\circ$ , respectively. Mole fractions of A and B in solution are  $X_A$  and  $X_B$ , respectively.

(i) Show that  $P_A = P_A^\circ X_A$

(Consider that the rates of vaporization and condensation are equal at equilibrium.)

- (ii) In the above system at 300 K, the total pressure was  $5.0 \times 10^4 \text{ Pa}$ . The saturated vapour pressures of pure A and B at 300 K, are  $7.0 \times 10^4 \text{ Pa}$  and  $3.0 \times 10^4 \text{ Pa}$ , respectively.
- Calculate the mole fraction of A in the liquid phase of the equilibrium mixture.
  - Calculate the vapour pressure of A in the equilibrium mixture.

(70 marks)

[see page eleven

7. (a) (i) To compare the properties of Electrolytic and Galvanic cells, copy and complete the following table using the given terms.

Terms: anode, cathode, positive, negative, spontaneous, non-spontaneous.

	Electrolytic cell	Galvanic cell
A. Oxidation half-reaction takes place at		
B. Reduction half-reaction takes place at		
C. Sign of $E_{\text{cell}}^{\circ}$		
D. Electron flow	From ..... to .....	From ..... to .....
E. Spontaneity of the cell reaction		

- (ii) An electrochemical cell was constructed at 300 K by using a Zn(s) anode, an aqueous alkaline electrolyte and a porous Pt cathode which facilitates the collection of oxygen  $\text{O}_2(\text{g})$  from air as shown below. As the cell operates ZnO(s) is produced.

You are given that

$$E_{\text{ZnO(s)}|\text{Zn(s)}|\text{OH}^{\text{(aq)}}}^{\circ} = -1.31 \text{ V and } E_{\text{O}_2(\text{g})|\text{OH}^{\text{(aq)}}}^{\circ} = +0.34 \text{ V}$$

$$\text{Zn} = 65 \text{ g mol}^{-1}, \text{O} = 16 \text{ g mol}^{-1} \text{ and}$$

$$1 F = 96,500 \text{ C}$$

- I. Write the half-reactions occurring at anode and cathode.

- II. Write the overall cell reaction.

- III. Calculate the cell potential  $E_{\text{cell}}^{\circ}$  at 300 K.

- IV. State the direction of migration of  $\text{OH}^{\text{(aq)}}$  ions between the electrodes.

- V. When the cell operates for a period of 800 s at 300 K, 2 mol of  $\text{O}_2(\text{g})$  are consumed.

- A. Calculate the number of moles of electrons passing through the cell.

- B. Calculate the mass of ZnO(s) formed.

- C. Calculate the current passing through the cell.

(75 marks)

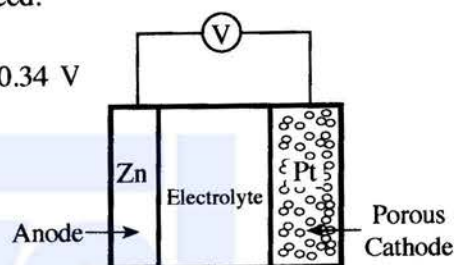

- (b) A coloured complex ion **P** is formed when the salt  $\text{M}(\text{NO}_3)_n$  is dissolved in distilled water. **M** is a transition element belonging to the 3d block. **P** undergoes the following reactions.

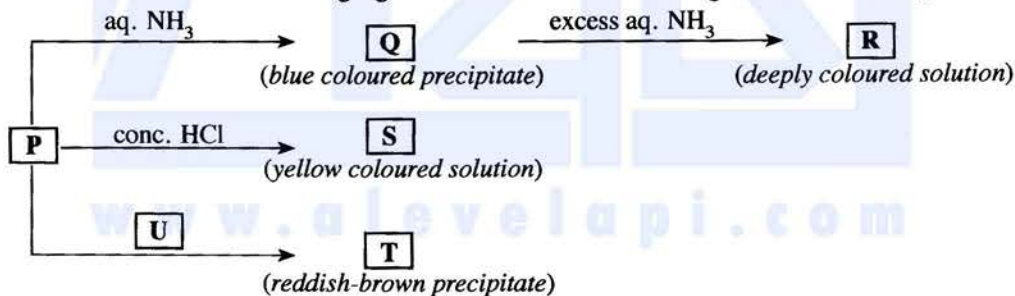

**T** and **U** are coordination compounds each containing four elements. **P**, **R** and **S** are complex ions.

- (i) Identify the metal **M**. Give the oxidation state of **M** in complex ion **P**.
- (ii) Give the value of  $n$  in  $\text{M}(\text{NO}_3)_n$ .
- (iii) Write the complete electronic configuration of **M** in complex ion **P**.
- (iv) Write the chemical formulae of **P**, **Q**, **R**, **S**, **T** and **U**.
- (v) Give the IUPAC names of **P**, **R**, **S**, **T** and **U**.
- (vi) What is the colour of **P**?
- (vii) What would you expect to observe in I and II given below?
  - I. When  $\text{H}_2\text{S}$  gas is passed into an acidic solution containing **P** at room temperature
  - II. When the mixture obtained in I above is heated with dilute  $\text{HNO}_3$  after the removal of dissolved  $\text{H}_2\text{S}$
- (viii) Briefly describe a method with the aid of balanced chemical equations for determining the concentration of  $\text{M}^{n+}$  present in an aqueous solution, using the following chemicals.

KI,  $\text{Na}_2\text{S}_2\text{O}_3$  and starch.

(75 marks)

[see page twelve

## PART C – ESSAY

Answer two questions only. (Each question carries 150 marks.)

8. (a) (i) Given below is a reaction scheme for the synthesis of compound G using  $\text{CH}_3\text{CH}_2\text{CH}_2\text{OH}$  as the only organic starting compound.

Complete the reaction scheme by drawing the structures of compounds A, B, C, D, E and F and writing the appropriate reagents for steps 1 – 7, selected only from those given in the list.

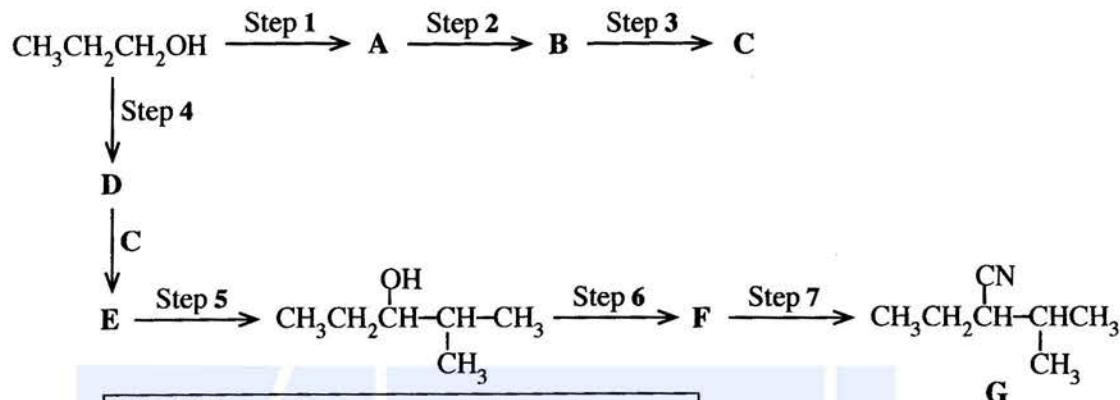

## List of Reagents

HBr, PBr<sub>3</sub>, pyridiniumchlorochromate (PCC),  
Mg / dry ether, KCN, conc. H<sub>2</sub>SO<sub>4</sub>, dil. H<sub>2</sub>SO<sub>4</sub>

(52 marks)

- (ii) Consider the following series of reactions.

Draw the structures of compounds G, H and K. Give the reagents X, Y and Z.

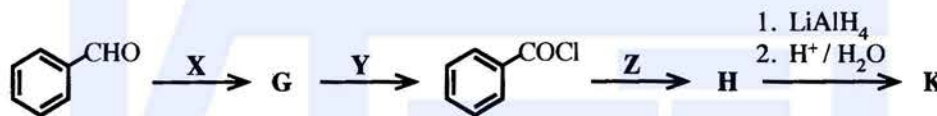

Note that K gives benzyl alcohol ( $\text{C}_6\text{H}_5\text{CH}_2\text{OH}$ ) when reacted with  $\text{NaNO}_2 / \text{dil. HCl}$ .

(24 marks)

- (b) (i) Show how the following conversion could be carried out in **not more than three steps**.



(20 marks)

- (ii) Consider the following reaction.

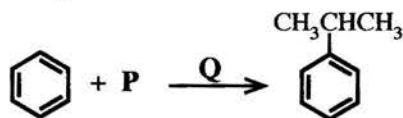

Identify the chemical substances P and Q necessary to carry out this reaction.

Write the mechanism of this reaction.

(20 marks)

- (c) (i) Explain why phenol is more reactive in electrophilic substitution reactions than benzene, by considering their resonance hybrids.

(ii) Illustrate the difference in reactivity between phenol and benzene as given in (i) above by means of a suitable reaction.

- (iii) Draw the structure(s) of product(s) you described in the reaction in (ii) above.

(34 marks)

[see page thirteen]

9. (a) (i) Write the chemical formulae of the substances A – Q given in the flow chart below.  
 (Note: Chemical equations and reasons are not expected for the identification of substances A – Q.)  
 The symbols given in the box (dash lines) are used to represent solids, precipitates, solutions and gases.

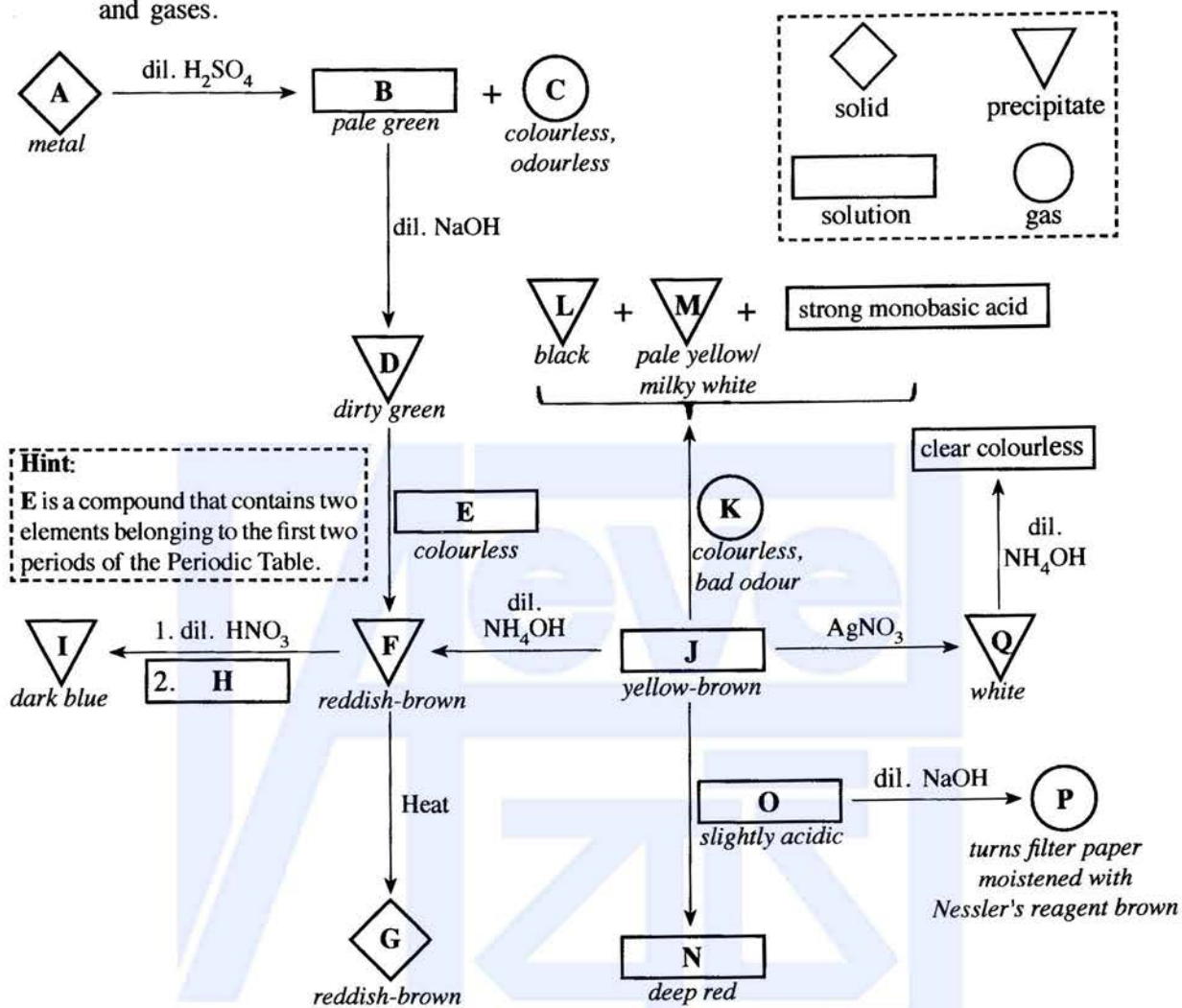

**Hint:**  
 E is a compound that contains two elements belonging to the first two periods of the Periodic Table.

- (ii) Write the complete electronic configuration of A.  
 (iii) State the function of E in the conversion of D to F. Give the relevant balanced chemical equations for the stated function. **(75 marks)**

(b) The solid X contains only Cu<sub>2</sub>S and CuS. The following procedure was used to determine the percentage of Cu<sub>2</sub>S in X.

**Procedure**

A 1.00 g portion of solid X was treated with 100.00 cm<sup>3</sup> of 0.16 mol dm<sup>-3</sup> KMnO<sub>4</sub> in dilute H<sub>2</sub>SO<sub>4</sub> medium. This reaction gave Mn<sup>2+</sup>, Cu<sup>2+</sup> and SO<sub>4</sub><sup>2-</sup> as products. Thereafter, the excess KMnO<sub>4</sub> in this solution was titrated with 0.15 mol dm<sup>-3</sup> Fe<sup>2+</sup> solution. The volume required for the titration was 35.00 cm<sup>3</sup>.

- (i) Write the balanced ionic equations for the reactions taking place in the above procedure.  
 (ii) Based on the answers to (i) above, determine the molar ratio between,  
 I. Cu<sub>2</sub>S and KMnO<sub>4</sub>  
 II. CuS and KMnO<sub>4</sub>  
 III. Fe<sup>2+</sup> and KMnO<sub>4</sub>  
 (iii) Calculate the percentage by weight of Cu<sub>2</sub>S in X. (Cu = 63.5, S = 32) **(75 marks)**

[see page fourteen

10. (a) The following questions are based on the properties of titanium dioxide ( $\text{TiO}_2$ ) and its manufacture carried out by the "Chloride Process".

- (i) Name the raw materials used in this process.
- (ii) Briefly describe the manufacturing process of  $\text{TiO}_2$  giving balanced chemical equations where applicable.
- (iii) State **three** properties of  $\text{TiO}_2$  and give one use each, relevant to each property.
- (iv) If you were to consider establishing a  $\text{TiO}_2$  manufacturing plant in Sri Lanka, state **three** requirements that need to be fulfilled.
- (v) Does the manufacturing process described in (ii) above contribute to global warming? Justify your answer. (50 marks)

(b) Currently, global warming due to change in greenhouse effect is significantly greater than that before the industrial revolution.

- (i) Explain briefly what is meant by greenhouse effect.
- (ii) Identify the major environmental problem that occurs due to global warming.
- (iii) State **two main** natural gases that contribute to global warming.
- (iv) Explain briefly how microorganisms contribute to the release of the gases you stated in (iii).
- (v) In addition to the gases you stated in (iii), name **two** classes of synthetic volatile compounds that directly contribute to the global warming, and selecting one compound from each class, draw their structures.
- (vi) Select **one** class of compounds from the two classes you stated in (v) that contributes to the catalytic degradation of ozone in the upper atmosphere.
- (vii) The slow down of industrial activities due to the Covid-19 pandemic temporarily eased the global environmental issues in many countries. Justify this statement by using **two** main global environmental issues you have learnt. (50 marks)

(c) The following questions are based on the polymers given below.

Polyvinyl chloride (PVC), Polyethylene (PE), Polystyrene (PS), Bakelite, Nylon 6.6, Polyethylene terephthalate (PET), Gutta percha

- (i) Draw the repeating units of **four** of the above polymers.
- (ii) Categorize each of the above seven (7) polymers as either,
  - I. natural or synthetic polymers.
  - II. addition or condensation polymers.
- (iii) Name the **two** monomers used in the formation of bakelite.
- (iv) Polymers can be grouped into two categories based on their thermal properties. State these **two** categories. Write to which of these categories PVC and bakelite belong.
- (v) Give **one** use each for **three** of the polymers given in the above list. (50 marks)

\* \* \*

[see page fifteen

**The Periodic Table**

1	1																2	
	<b>H</b>																<b>He</b>	
2	3	4										5	6	7	8	9	10	
	<b>Li</b>	<b>Be</b>										<b>B</b>	<b>C</b>	<b>N</b>	<b>O</b>	<b>F</b>	<b>Ne</b>	
3	11	12										13	14	15	16	17	18	
	<b>Na</b>	<b>Mg</b>										<b>Al</b>	<b>Si</b>	<b>P</b>	<b>S</b>	<b>Cl</b>	<b>Ar</b>	
4	19	20	21	22	23	24	25	26	27	28	29	30	31	32	33	34	35	36
	<b>K</b>	<b>Ca</b>	<b>Sc</b>	<b>Ti</b>	<b>V</b>	<b>Cr</b>	<b>Mn</b>	<b>Fe</b>	<b>Co</b>	<b>Ni</b>	<b>Cu</b>	<b>Zn</b>	<b>Ga</b>	<b>Ge</b>	<b>As</b>	<b>Se</b>	<b>Br</b>	<b>Kr</b>
5	37	38	39	40	41	42	43	44	45	46	47	48	49	50	51	52	53	54
	<b>Rb</b>	<b>Sr</b>	<b>Y</b>	<b>Zr</b>	<b>Nb</b>	<b>Mo</b>	<b>Tc</b>	<b>Ru</b>	<b>Rh</b>	<b>Pd</b>	<b>Ag</b>	<b>Cd</b>	<b>In</b>	<b>Sn</b>	<b>Sb</b>	<b>Te</b>	<b>I</b>	<b>Xe</b>
6	55	56	La-	72	73	74	75	76	77	78	79	80	81	82	83	84	85	86
	<b>Cs</b>	<b>Ba</b>	<b>Lu</b>	<b>Hf</b>	<b>Ta</b>	<b>W</b>	<b>Re</b>	<b>Os</b>	<b>Ir</b>	<b>Pt</b>	<b>Au</b>	<b>Hg</b>	<b>Tl</b>	<b>Pb</b>	<b>Bi</b>	<b>Po</b>	<b>At</b>	<b>Rn</b>
7	87	88	Ac-	104	105	106	107	108	109	110	111	112	113	114	115	116	117	118
	<b>Fr</b>	<b>Ra</b>	<b>Lr</b>	<b>Rf</b>	<b>Db</b>	<b>Sg</b>	<b>Bh</b>	<b>Hs</b>	<b>Mt</b>	<b>Ds</b>	<b>Rg</b>	<b>Cn</b>	<b>Nh</b>	<b>Fl</b>	<b>Mc</b>	<b>Lv</b>	<b>Ts</b>	<b>Og</b>

57	58	59	60	61	62	63	64	65	66	67	68	69	70	71
<b>La</b>	<b>Ce</b>	<b>Pr</b>	<b>Nd</b>	<b>Pm</b>	<b>Sm</b>	<b>Eu</b>	<b>Gd</b>	<b>Tb</b>	<b>Dy</b>	<b>Ho</b>	<b>Er</b>	<b>Tm</b>	<b>Yb</b>	<b>Lu</b>
89	90	91	92	93	94	95	96	97	98	99	100	101	102	103
<b>Ac</b>	<b>Th</b>	<b>Pa</b>	<b>U</b>	<b>Np</b>	<b>Pu</b>	<b>Am</b>	<b>Cm</b>	<b>Bk</b>	<b>Cf</b>	<b>Es</b>	<b>Fm</b>	<b>Md</b>	<b>No</b>	<b>Lr</b>







NEW

Department of Examinations - Sri Lanka  
G.C.E. (A/L) Examination - 2020

# 02 - Chemistry

## New Syllabus

Marking Scheme

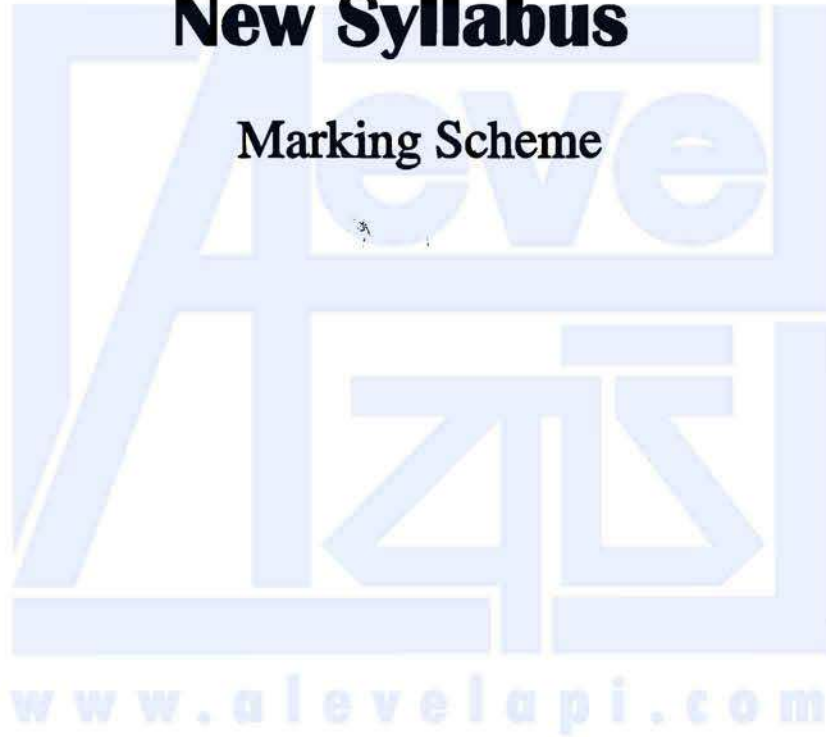

This document has been prepared for the use of Marking Examiners. Some changes would be made according to the views presented at the Chief Examiners' meeting.

Amendments to be included

## G.C.E. (A/L) Examination - 2020

### 02 - Chemistry (New Syllabus)

#### Distribution of Marks

**Paper I** : 1 X 50 = 50

**Paper II** :

Part A : 100 X 4 = 400

Part B : 150 X 2 = 300

Part C : 150 X 2 = 300

**Total** = 1000

**Paper II - Final Marks** = 100

### Common Techniques of Marking Answer Scripts.

It is compulsory to adhere to the following standard method in marking answer scripts and entering marks into the mark sheets.

1. Use a red color ball point pen for marking. (Only Chief/Additional Chief Examiner may use a mauve color pen.)
2. Note down Examiner's Code Number and initials on the front page of each answer script.
3. Write off any numerals written wrong with a clear single line and authenticate the alterations with Examiner's initials.
4. Write down marks of each subsection in a  $\triangle$  and write the final marks of each question as a rational number in a  $\square$  with the question number. Use the column assigned for Examiners to write down marks.

Example:

Question No. 03

(i)	..... ..... .....	✓	$\triangle \frac{4}{5}$
(ii)	..... ..... .....	✓	$\triangle \frac{3}{5}$
(iii)	..... ..... .....	✓	$\triangle \frac{3}{5}$

03 (i)  $\frac{4}{5}$  + (ii)  $\frac{3}{5}$  + (iii)  $\frac{3}{5}$  =  $\square \frac{10}{15}$

### MCQ answer scripts: (Template)

1. Marking templets for G.C.E.(A/L) and GIT examination will be provided by the Department of Examinations itself. Marking examiners bear the responsibility of using correctly prepared and certified templates.
2. Then, check the answer scripts carefully. If there are more than one or no answers Marked to a certain question write off the options with a line. Sometimes candidates may have erased an option marked previously and selected another option. In such occasions, if the erasure is not clear write off those options too.
3. Place the template on the answer script correctly. Mark the right answers with a 'V' and the wrong answers with a 'X' against the options column. Write down the number of correct answers inside the cage given under each column. Then, add those numbers and write the number of correct answers in the relevant cage.

**structured essay type and assay type answer scripts:**

1. Cross off any pages left blank by candidates. Underline wrong or unsuitable answers. Show areas where marks can be offered with check marks.
2. Use the right margin of the overland paper to write down the marks.
3. Write down the marks given for each question against the question number in the relevant cage on the front page in two digits. Selection of questions should be in accordance with the instructions given in the question paper. Mark all answers and transfer the marks to the front page, and write off answers with lower marks if extra questions have been answered against instructions.
4. Add the total carefully and write in the relevant cage on the front page. Turn pages of answer script and add all the marks given for all answers again. Check whether that total tallies with the total marks written on the front page.

**Preparation of Mark Sheets.**

Except for the subjects with a single question paper, final marks of two papers will not be calculated within the evaluation board this time. Therefore, add separate mark sheets for each of the question paper. Write paper 01 marks in the paper 01 column of the mark sheet and write them in words too. Write paper II Marks in the paper II Column and write the relevant details. For the subject 51 Art, marks for Papers 01, 02 and 03 should be entered numerically in the mark sheets.

\*\*\*

සියලු ම හිමිකම් ඇවිරිණි / முழுப் பதிப்புரிமையுடையது / All Rights Reserved

නව නිර්දේශය/புதிய பாடத்திட்டம்/New Syllabus

**NEW**  
 Department of Examinations, Sri Lanka  
 இலங்கைப் பரீட்சைத்துறை, சிறீலங்கா  
 Department of Examinations, Sri Lanka

අධ්‍යයන ජනපද සහතික පත්‍ර (උසස් පෙළ) විභාගය, 2020  
 கல்விப் பொதுத் தராதரப் பத்திர (உயர் தர)ப் பரீட்சை, 2020  
 General Certificate of Education (Adv. Level) Examination, 2020

රසායන විද්‍යාව I  
 இரசாயனவியல் I  
 Chemistry I

02 E I

පැය දෙකයි  
 இரண்டு மணித்தியாலம்  
 Two hours

- Instructions:**
- \* Periodic Table is provided.
  - \* This paper consists of 09 pages.
  - \* Answer all the questions.
  - \* Use of calculators is not allowed.
  - \* Write your Index Number in the space provided in the answer sheet.
  - \* Follow the instructions given on the back of the answer sheet carefully.
  - \* In each of the questions 1 to 50, pick one of the alternatives from (1), (2), (3), (4), (5) which is correct or most appropriate and mark your response on the answer sheet with a cross (x) in accordance with the instructions given on the back of the answer sheet.

Universal gas constant  $R = 8.314 \text{ J K}^{-1} \text{ mol}^{-1}$       Planck's constant  $h = 6.626 \times 10^{-34} \text{ Js}$   
 Avogadro constant  $N_A = 6.022 \times 10^{23} \text{ mol}^{-1}$       Velocity of light  $c = 3 \times 10^8 \text{ m s}^{-1}$

- Consider the following discoveries made with regard to the atomic structure.
  - Positive rays inside a cathode ray tube
  - Radioactivity by certain types of nuclei
 The two scientists who discovered the above stated I and II respectively, are,
  - J.J.Thomson and Henry Becquerel
  - Eugen Goldstein and Robert Millikan
  - Henry Becquerel and Eugen Goldstein
  - J.J.Thomson and Ernest Rutherford
  - Eugen Goldstein and Henry Becquerel
- The number of electrons in the manganese atom (Mn, Z = 25) that have quantum numbers  $l = 0$  and  $m_l = -1$  respectively are,
  - 6 and 4
  - 8 and 12
  - 8 and 5
  - 8 and 6
  - 10 and 5
- M is an element that belongs to the second period in the Periodic Table. It forms a covalent molecule  $\text{MCl}_3$  which has a dipole moment. The group of the Periodic Table to which M belongs is,
  - 2
  - 13
  - 14
  - 15
  - 16
- The number of unstable Lewis dot-dash structures that can be drawn for the peroxyntic acid molecule (formula  $\text{HNO}_4$ ,  $\text{H}-\ddot{\text{O}}-\ddot{\text{O}}-\overset{\text{O}}{\parallel}{\text{N}}-\ddot{\text{O}}^-$ ) is,
  - 1
  - 2
  - 3
  - 4
  - 5
- The IUPAC name of the given compound is,
  - 1-bromo-4-methyl-5-hydroxypent-1-en-3-one
  - 5-bromo-1-hydroxy-2-methylpent-4-en-3-one
  - 1-bromo-5-hydroxy-4-methylpent-1-en-3-one
  - 5-bromo-2-methyl-3-oxopent-4-en-1-ol
  - 1-bromo-4-methyl-3-oxopent-1-enol

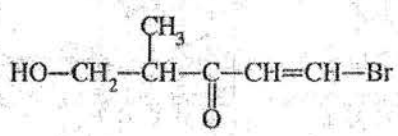

See page two

AL/2020/02/E-I(NEW)

6. The decreasing order of radii of the species O, O<sup>2-</sup>, F, F<sup>-</sup>, S<sup>2-</sup>, Cl<sup>-</sup> is,

- (1) S<sup>2-</sup> > Cl<sup>-</sup> > O<sup>2-</sup> > F<sup>-</sup> > O > F
- (2) S<sup>2-</sup> > Cl<sup>-</sup> > O<sup>2-</sup> > F<sup>-</sup> > F > O
- (3) Cl<sup>-</sup> > S<sup>2-</sup> > O<sup>2-</sup> > F<sup>-</sup> > O > F
- (4) Cl<sup>-</sup> > S<sup>2-</sup> > F<sup>-</sup> > O<sup>2-</sup> > O > F
- (5) S<sup>2-</sup> > Cl<sup>-</sup> > O<sup>2-</sup> > O > F<sup>-</sup> > F

7. A rigid-closed container contains n<sub>1</sub> moles of an ideal gas at temperature T<sub>1</sub>(K) and pressure P<sub>1</sub>(Pa). When an additional amount of the gas was inserted into the container, the new temperature and pressure were T<sub>2</sub> and P<sub>2</sub>, respectively. The total number of moles of the gas now in the container is,

- (1)  $\frac{n_1 T_1 P_1}{T_2 P_2}$
- (2)  $\frac{n_1 T_1 P_2}{T_2 P_1}$
- (3)  $\frac{T_2 P_2}{n_1 T_1 P_1}$
- (4)  $\frac{n_1 T_1 P_2}{T_1 P_1}$
- (5)  $\frac{n_1 T_1 P_1}{T_1 P_2}$

8. The total number of electrons exchanged in the reaction of the oxidation of ethanol (C<sub>2</sub>H<sub>5</sub>OH) to acetic acid (CH<sub>3</sub>COOH) using acidic K<sub>2</sub>Cr<sub>2</sub>O<sub>7</sub> solution is,

- (1) 6
- (2) 8
- (3) 10
- (4) 12
- (5) 14

9. Which compound of the following, can undergo aldol condensation, when reacted with aqueous NaOH?

- (1) CH<sub>3</sub>C(=O)OH
- (2) CH<sub>3</sub>C(=O)OCH<sub>3</sub>
- (3) H-C(=O)OCH<sub>3</sub>
- (4) CH<sub>3</sub>CH<sub>2</sub>C(=O)H
- (5) (CH<sub>3</sub>)<sub>3</sub>CC(=O)H

10. AX(s), A<sub>2</sub>Y(s) and AZ(s) are sparingly soluble salts in water having K<sub>sp</sub> values of 1.6 × 10<sup>-9</sup>, 3.2 × 10<sup>-11</sup> and 9.0 × 10<sup>-12</sup>, respectively at 25 °C. Which of the following shows the order of the three saturated solutions of these salts in decreasing concentration of cation A<sup>+</sup>(aq), at 25 °C?

- (1) AX(s) > A<sub>2</sub>Y(s) > AZ(s)
- (2) A<sub>2</sub>Y(s) > AX(s) > AZ(s)
- (3) AX(s) > AZ(s) > A<sub>2</sub>Y(s)
- (4) A<sub>2</sub>Y(s) > AZ(s) > AX(s)
- (5) AZ(s) > A<sub>2</sub>Y(s) > AX(s)

11. Consider the following compounds.

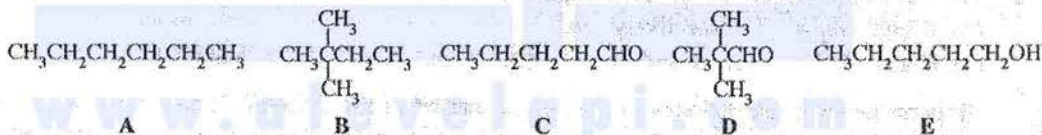

Relative molecular mass	86	86	86	86	88
-------------------------	----	----	----	----	----

Variation of boiling points of these compounds is best shown by,

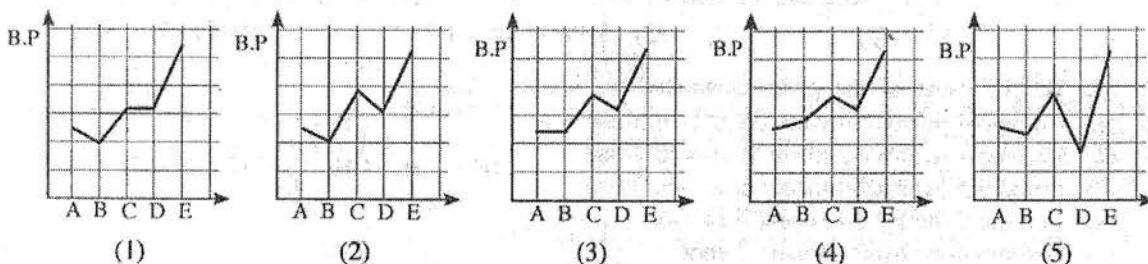

[See page three

AL/2020/02/E-I(NEW)

12. The increasing order of covalent character of the chemical species NaCl, Na<sub>2</sub>S, KF and KCl is,

- (1) KF < NaCl < KCl < Na<sub>2</sub>S  
 (2) KCl < NaCl < KF < Na<sub>2</sub>S  
 (3) KF < KCl < NaCl < Na<sub>2</sub>S  
 (4) Na<sub>2</sub>S < NaCl < KCl < KF  
 (5) KF < Na<sub>2</sub>S < NaCl < KCl

13. Standard combustion enthalpies of H<sub>2</sub>(g), C(s) and CH<sub>3</sub>OH(l) at 298 K are -286 kJ mol<sup>-1</sup>, -393 kJ mol<sup>-1</sup> and -726 kJ mol<sup>-1</sup>, respectively. Enthalpy of vaporization of CH<sub>3</sub>OH(l) is +37 kJ mol<sup>-1</sup>. Enthalpy of formation (kJ mol<sup>-1</sup>) of one mole of gaseous CH<sub>3</sub>OH at 298 K is,

- (1) -276                      (2) -239                      (3) -202                      (4) +84                      (5) +202

14. Phosphorous can be prepared in an electric furnace as given by the following balanced chemical equation.



When 620 g of Ca<sub>3</sub>(PO<sub>4</sub>)<sub>2</sub>, 180 g of SiO<sub>2</sub> and 96 g of C were reacted, 50 g of P<sub>4</sub> were obtained. Under these conditions, the limiting reagent (reagent that is completely consumed) and percentage yield of P<sub>4</sub> respectively are, (C = 12, O = 16, Si = 28, P = 31, Ca = 40)

- (1) Ca<sub>3</sub>(PO<sub>4</sub>)<sub>2</sub> and 80.7%                      (2) SiO<sub>2</sub> and 80.7%                      (3) C and 50.4%  
 (4) SiO<sub>2</sub> and 40.3%                      (5) C and 25.2%

15. Consider the following two equilibria occurring in two separate rigid-closed containers under the same conditions.



Under these conditions K<sub>p</sub> for the equilibrium 2H<sub>2</sub>S(g) + N<sub>2</sub>(g) + 3H<sub>2</sub>(g) ⇌ 2NH<sub>4</sub>HS(g) is,

- (1) 5.76 × 10<sup>-12</sup>                      (2) 7.2 × 10<sup>-10</sup>                      (3) 1.92 × 10<sup>-8</sup>                      (4) 3.40 × 10<sup>-6</sup>                      (5) 3.75 × 10<sup>-2</sup>

16. Consider the nitration reaction of bromobenzene. Resonance stabilized carbocation intermediates are formed during this reaction. Which of the following is **not** a resonance structure of these intermediates?

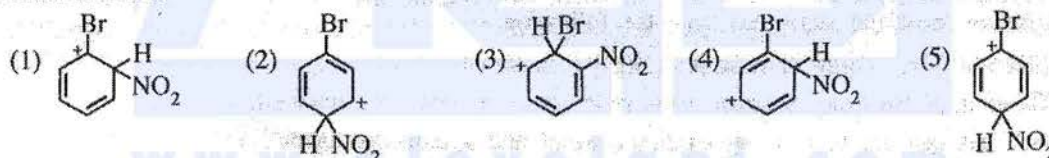

17. A reaction which is non-spontaneous at room temperature and 1 atm pressure becomes spontaneous at high temperature at the same pressure. Which of the following is correct for this reaction at room temperature? (Assume that ΔH and ΔS do not change with temperature and pressure.)

- |     | ΔG       | ΔH       | ΔS       |
|-----|----------|----------|----------|
| (1) | Positive | Positive | Positive |
| (2) | Positive | Negative | Negative |
| (3) | Positive | Negative | Positive |
| (4) | Negative | Positive | Negative |
| (5) | Negative | Negative | Negative |

18. The de Broglie wavelength of a neutron travelling with a velocity v is λ. If the kinetic energy E (E =  $\frac{1}{2}mv^2$ ) of this neutron is increased four times, the new de Broglie wavelength would be,

- (1)  $\frac{\lambda}{2}$                       (2)  $\frac{\lambda}{4}$                       (3) 2λ                      (4) 4λ                      (5) 16λ

AL/2020/02/E-I(NEW)

19. Which of the following correctly shows the electrolytic cell constructed for the electrolysis of an aqueous solution of the salt MX?

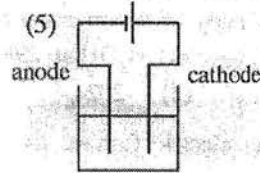
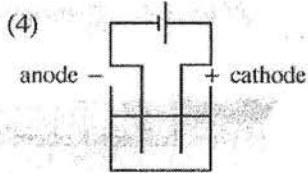
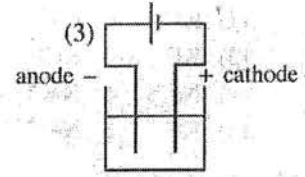
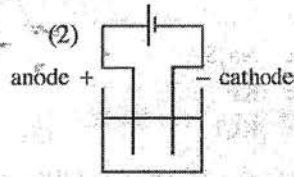
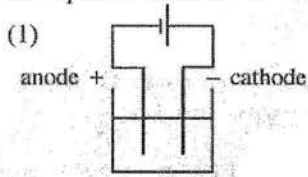

20. Which of the following statements is correct regarding the reaction between a carboxylic acid and an alcohol to give an ester?

- (1) The overall reaction is a nucleophilic addition reaction of a carbonyl compound.
- (2) It is a reaction in which the alcohol acts as a nucleophile.
- (3) It is a reaction which occurs with the cleavage of the O–H bond of the carboxylic acid.
- (4) It is a reaction which occurs with the cleavage of the C–O bond of the alcohol.
- (5) It is an acid-base reaction.

21. Decomposition of 1 mol of  $\text{CH}_3\text{OH}(l)$  occurs at high temperatures as follows.

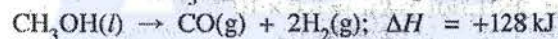

Which of the following is **incorrect** for the above reaction? (H=1, C=12, O=16)

- (1) The heat absorbed when 1 mol of  $\text{CH}_3\text{OH}(g)$  is decomposed is less than 128 kJ.
  - (2) Enthalpy of  $\text{CO}(g) + 2\text{H}_2(g)$  is higher than the enthalpy of  $\text{CH}_3\text{OH}(l)$ .
  - (3) 128 kJ of heat is released when 1 mol of  $\text{CO}(g)$  is formed.
  - (4) 128 kJ of heat is absorbed during the decomposition of a mole of reactant.
  - (5) 128 kJ of heat is absorbed when 32 g of products are formed.
22. Identify the **incorrect** statement from the following.
- (1) Electron gain energy of nitrogen  $[\text{N}(g)]$  is positive.
  - (2) Dilution of  $\text{BiCl}_3(\text{aq})$  solution with water gives a white precipitate.
  - (3)  $\text{H}_2\text{S}$  gas can act both as an oxidizing agent and a reducing agent.
  - (4) The effective nuclear charge ( $Z^*$ ) felt by a valence electron in He is less than 2.
  - (5) Aluminium is inert towards  $\text{N}_2$  gas even when heated to a high temperature.
23. The concentration of a dilute aqueous solution of a weak acid HA is  $C \text{ mol dm}^{-3}$  and its acid dissociation constant is  $K_a$  at 298 K. Which of the following expressions gives the pH of the solution at 298 K?
- (1)  $\text{pH} = \frac{1}{2} \text{p}K_a - \frac{1}{2} \log C$
  - (2)  $\text{pH} = -\frac{1}{2} \text{p}K_a - \frac{1}{2} \log C$
  - (3)  $\text{pH} = -\frac{1}{2} \text{p}K_a + \frac{1}{2} \log C$
  - (4)  $\text{pH} = -\frac{1}{2} \text{p}K_a - \frac{1}{2} \log (1/C)$
  - (5)  $\text{pH} = \frac{1}{2} \text{p}K_a - \frac{1}{2} \log (1/C)$



AL/2020/02/E-I(NEW)

24. The strength of a  $\text{H}_2\text{O}_2$  solution can be expressed as the volume of  $\text{O}_2$  produced at standard temperature and pressure (STP). For example, a litre of 20 volume strength  $\text{H}_2\text{O}_2$  solution will produce 20 litres of  $\text{O}_2$  gas at STP ( $2\text{H}_2\text{O}_2(\text{aq}) \rightarrow 2\text{H}_2\text{O}(\text{l}) + \text{O}_2(\text{g})$ ). (Assume that 1 mole of gas has 22.4 litres volume at STP.)

A bottle labelled X contains  $\text{H}_2\text{O}_2$  solution. When  $25.0\text{ cm}^3$  of solution X was titrated with  $1.0\text{ mol dm}^{-3}$   $\text{KMnO}_4$  in the presence of dilute  $\text{H}_2\text{SO}_4$  the volume required to reach the end point was  $25.0\text{ cm}^3$ . The volume strength of solution X is,

- (1) 15                      (2) 20                      (3) 25                      (4) 28                      (5) 30

25.  $\text{M}(\text{OH})_2(\text{s})$  is a sparingly water soluble salt formed by the reaction between  $\text{M}^{2+}(\text{aq})$  and  $\text{OH}^-(\text{aq})$  ions at 298 K. The solubility ( $\text{mol dm}^{-3}$ ) of  $\text{M}(\text{OH})_2(\text{s})$  in water at  $\text{pH} = 5$  is, ( $K_{sp}\text{M}(\text{OH})_2 = 4.0 \times 10^{-36}$  at 298 K).

- (1)  $\sqrt{2} \times 10^{-18}$       (2)  $2 \times 10^{-18}$       (3)  $1 \times 10^{-18}$       (4)  $\sqrt[3]{2} \times 10^{-12}$       (5)  $1 \times 10^{-12}$

26. Which of the following correctly denotes the standard galvanic cell constructed by using a standard hydrogen electrode, a standard Mg-electrode and a salt-bridge at 298 K?

- (1)  $\text{Mg}(\text{s}) | \text{Mg}^{2+}(\text{aq}, 1.00\text{ mol dm}^{-3}) || \text{H}^+(\text{aq}, 1.00\text{ mol dm}^{-3}) | \text{H}_2(\text{g}) | \text{Pt}(\text{s})$   
 (2)  $\text{Pt}(\text{s}) | \text{H}_2(\text{g}) | \text{H}^+(\text{aq}, 1.00\text{ mol dm}^{-3}) || \text{Mg}^{2+}(\text{aq}, 1.00\text{ mol dm}^{-3}) | \text{Mg}(\text{s})$   
 (3)  $\text{Mg}(\text{s}), \text{Mg}^{2+}(\text{aq}, 1.00\text{ mol dm}^{-3}) || \text{H}^+(\text{aq}, 1.00\text{ mol dm}^{-3}) | \text{H}_2(\text{g}) | \text{Pt}(\text{s})$   
 (4)  $\text{Mg}(\text{s}) | \text{Mg}^{2+}(\text{aq}, 1.00\text{ mol dm}^{-3}), \text{H}^+(\text{aq}, 1.00\text{ mol dm}^{-3}), \text{H}_2(\text{g}) | \text{Pt}(\text{s})$   
 (5)  $\text{Pt}(\text{s}), \text{H}_2(\text{g}) | \text{H}^+(\text{aq}, 1.00\text{ mol dm}^{-3}) || \text{Mg}^{2+}(\text{aq}, 1.00\text{ mol dm}^{-3}), \text{Mg}(\text{s})$

27. The following procedure was carried out at 298 K to determine the distribution coefficient  $K_D$  of a monobasic organic acid between dichloromethane and water.  $50.00\text{ cm}^3$  of a  $0.20\text{ mol dm}^{-3}$  aqueous solution of acid were mixed vigorously with  $10.00\text{ cm}^3$  of dichloromethane and the two layers were allowed to separate. Thereafter, the dichloromethane layer in the bottom of the flask was drained out.  $10.00\text{ cm}^3$  of  $0.02\text{ mol dm}^{-3}$   $\text{NaOH}(\text{aq})$  solution were required to neutralize the acid remaining in the aqueous layer. (Assume that the acid does not dimerize in the organic phase.)  $K_D$  of the acid between dichloromethane and water at 298 K is,

- (1) 0.05                      (2) 0.25                      (3) 4.00                      (4) 20.00                      (5) 245.00

28. A reaction  $\text{C}_2\text{H}_4(\text{g}) + 3\text{O}_2(\text{g}) \rightarrow 2\text{CO}_2(\text{g}) + 2\text{H}_2\text{O}(\text{g})$  occurs in a rigid-closed container at a given temperature. After a certain time, it was found that the rate of the reaction with respect to consumption of  $\text{C}_2\text{H}_4(\text{g})$  was  $x\text{ mol dm}^{-3}\text{ s}^{-1}$ . Which of the following shows the rates of consumption of  $\text{O}_2(\text{g})$ , formation of  $\text{CO}_2(\text{g})$  and formation of  $\text{H}_2\text{O}(\text{g})$  respectively, during that time?

- |     | rate / $\text{mol dm}^{-3}\text{ s}^{-1}$ |                         |                                |
|-----|---|-------------------------|--------------------------------|
|     | $\text{O}_2(\text{g})$                    | $\text{CO}_2(\text{g})$ | $\text{H}_2\text{O}(\text{g})$ |
| (1) | $\frac{3}{x}$                             | $\frac{2}{x}$           | $\frac{2}{x}$                  |
| (2) | $x$                                       | $x$                     | $x$                            |
| (3) | $\frac{x}{3}$                             | $\frac{x}{2}$           | $\frac{x}{2}$                  |
| (4) | $\frac{1}{x}$                             | $\frac{1}{x}$           | $\frac{1}{x}$                  |
| (5) | $3x$                                      | $2x$                    | $2x$                           |

29. Consider the following reaction occurring in a rigid-closed container at temperature  $T$ .



The rate of reaction doubled when the concentration of M was doubled. The rate of reaction is  $5.00 \times 10^{-4}\text{ mol dm}^{-3}\text{ s}^{-1}$  when the concentrations of M and Q are  $1.0 \times 10^{-5}\text{ mol dm}^{-3}$  and  $2.0\text{ mol dm}^{-3}$  respectively. The rate constant of the reaction under these conditions is,







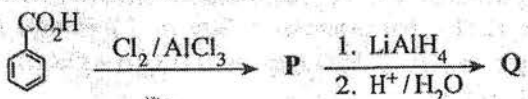



- (1)  $2.5 \times 10^{-4}\text{ s}^{-1}$       (2)  $12.5\text{ s}^{-1}$       (3)  $25\text{ s}^{-1}$       (4)  $50\text{ s}^{-1}$       (5)  $500\text{ s}^{-1}$

AL/2020/02/E-I(NEW)

30. Consider the following reaction scheme.



P and Q respectively could be,

- (1)  and  (2)  and  (3)  and   
 (4)  and  (5)  and 

● For each of the questions 31 to 40, one or more responses out of the four responses (a), (b), (c) and (d) given is/are correct. Select the correct response/responses. In accordance with the instructions given on your answer sheet, mark

- (1) if only (a) and (b) are correct.  
 (2) if only (b) and (c) are correct.  
 (3) if only (c) and (d) are correct.  
 (4) if only (d) and (a) are correct.  
 (5) if any other number or combination of responses is correct.

Summary of above Instructions

(1)	(2)	(3)	(4)	(5)
Only (a) and (b) are correct	Only (b) and (c) are correct	Only (c) and (d) are correct	Only (d) and (a) are correct	Any other number or combination of responses is correct

31. Which of the following statement/s is/are correct with regard to 3d-block elements and their compounds?

- (a) Among the 3d-block elements, Sc is not considered as a transition element.  
 (b) The radii of atoms (Sc to Cu) decrease from left to right.  
 (c)  $[\text{Ni}(\text{NH}_3)_6]^{2+}$  is blue in colour whereas  $[\text{Zn}(\text{NH}_3)_4]^{2+}$  is colourless.  
 (d) The IUPAC name of  $\text{K}_2\text{NiCl}_4$  is dipotassium tetrachloronickelate(II).

32. Which statement/s is/are correct regarding the following molecule?

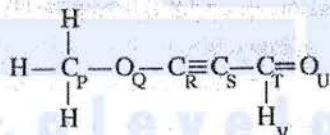

- (a) Atoms labelled P, Q, R and S lie on a straight line.  
 (b) Atoms labelled Q, R, S and T lie on a straight line.  
 (c) Atoms labelled R, S, T, U and V lie on the same plane.  
 (d) Atoms labelled R, S, T and U lie on a straight line.

33. 0.01 moles of  $\text{N}_2(\text{g})$ , 0.10 moles of  $\text{H}_2(\text{g})$  and 0.40 moles of  $\text{NH}_3(\text{g})$  were inserted into a  $1.0 \text{ dm}^3$  rigid-closed container and allowed to reach equilibrium at 500 K as given below.

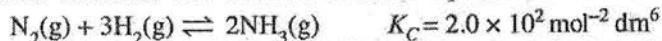

Which of the following statement/s is/are correct for the changes in the system from the initial stage to equilibrium?  $Q_C$  is the reaction quotient.

- (a) Initially  $Q_C > K_C$ ;  $\text{NH}_3(\text{g})$  starts to produce  $\text{N}_2(\text{g})$  and  $\text{H}_2(\text{g})$  and the system reaches equilibrium.  
 (b) Initially  $Q_C < K_C$ ;  $\text{NH}_3(\text{g})$  starts to produce  $\text{N}_2(\text{g})$  and  $\text{H}_2(\text{g})$  and the system reaches equilibrium.  
 (c) Initially  $Q_C < K_C$ ;  $\text{N}_2(\text{g})$  and  $\text{H}_2(\text{g})$  react to form  $\text{NH}_3(\text{g})$  and the system reaches equilibrium.  
 (d) Initially  $Q_C > K_C$ ;  $\text{N}_2(\text{g})$  and  $\text{H}_2(\text{g})$  react to form  $\text{NH}_3(\text{g})$  and the system reaches equilibrium.

[See page seven

34. Which of the following statement/s regarding the reaction between compound **P** and HCl to form an alkyl halide is/are correct?

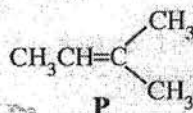

- (a) The major product is 2-chloro-2-methylbutane.  
 (b) A secondary carbocation is formed as an intermediate in this reaction.  
 (c) In one of the steps of the reaction, the HCl bond is cleaved to give a chlorine radical (Cl<sup>•</sup>).  
 (d) In one of the steps of the reaction, a nucleophile reacts with a carbocation.
35. A binary liquid mixture prepared by mixing two liquids in a closed evacuated container at a given temperature shows a negative deviation from Rault's Law. Which of the following statement/s is/are correct for this system?
- (a) Total vapour pressure of the mixture is less than the expected total vapour pressure should it behave as an ideal mixture.  
 (b) Heat is released when the mixture is formed.  
 (c) Number of molecules in the vapour phase of the mixture is greater than the expected number of molecules should it behave as an ideal mixture.  
 (d) Heat is absorbed when the mixture is formed.
36. Which of the following statement/s is/are correct with regard to CFC, HCFC and HFC?
- (a) Both classes of compounds CFC and HCFC have the ability to produce chlorine free radicals in the upper atmosphere (stratosphere).  
 (b) Both classes of compounds HFC and HCFC have the ability to produce chlorine free radicals in the upper atmosphere (stratosphere).  
 (c) All three classes of compounds CFC, HCFC and HFC are strong greenhouse gases.  
 (d) All three classes of compounds CFC, HCFC and HFC contribute significantly to ozone layer depletion.
37. Which of the following statement/s is/are correct with regard to halogens, noble gases and their compounds?
- (a) Hypochlorous ion disproportionates rapidly in acidic solutions.  
 (b) Xe forms a series of compounds with F<sub>2</sub> gas, among which XeF<sub>4</sub> has a square planar geometry.  
 (c) Among the hydrogen halides, HF has the highest bond dissociation energy per mole.  
 (d) Boiling points of halogens increase down the group as a result of increasing strength of London forces.
38. Which of the following statement/s is/are correct regarding the Daniell cell when it operates at room temperature? ( $E_{\text{cell}}^{\circ} = +1.10 \text{ V}$ )
- (a) Net electron flow occurs from Zn to Cu.  
 (b) The equilibrium  $\text{Zn}^{2+}(\text{aq}) + 2\text{e} \rightleftharpoons \text{Zn}(\text{s})$  shifts to the right.  
 (c) A liquid-junction potential is created due to the presence of a salt-bridge.  
 (d) The equilibrium  $\text{Cu}^{2+}(\text{aq}) + 2\text{e} \rightleftharpoons \text{Cu}(\text{s})$  shifts to the right.
39. Which of the following statement/s is/are correct for ideal gases and real gases at constant temperature?
- (a) At very high pressures, the volume of a real gas is higher than that of an ideal gas.  
 (b) At high pressures, real gases tend to behave as ideal gases.  
 (c) At very high pressures, the volume of a real gas is lower than that of an ideal gas.  
 (d) At low pressures, real gases tend to behave as ideal gases.
40. Which of the following statement/s is/are correct regarding some industrial processes?
- (a) The first two steps involved in the manufacture of Na<sub>2</sub>CO<sub>3</sub> by Solvay Process are endothermic.  
 (b) The presence of Mg<sup>2+</sup>, Ca<sup>2+</sup> and SO<sub>4</sub><sup>2-</sup> ions in brine, hinders the production of NaOH using the membrane cell method.  
 (c) The first step involved in the manufacture of nitric acid by Ostwald method is the oxidation of NH<sub>3</sub> gas using O<sub>2</sub> in air in the presence of a catalyst to give NO<sub>2</sub> gas.  
 (d) High temperature and low pressure conditions are employed in the manufacture of NH<sub>3</sub> gas using Haber-Bosh process.

I See none eight

AL/2020/02/E-I(NEW)

- In question Nos. 41 to 50, two statements are given in respect of each question. From the Table given below, select the response, out of the responses (1), (2), (3), (4) and (5), that best fits the two statements and mark appropriately on your answer sheet.

Response	First Statement	Second Statement
(1)	True	True, and correctly explains the first statement
(2)	True	True, but does not explain the first statement correctly
(3)	True	False
(4)	False	True
(5)	False	False

	First Statement	Second statement
41.	Among the oxides of Cr and Mn, CrO and MnO are acidic, while CrO <sub>3</sub> and Mn <sub>2</sub> O <sub>7</sub> are basic.	The acidic/basic nature of the oxides of Cr and Mn is dependant on the oxidation number of the metal.
42.	An acidic buffer solution can be prepared by mixing a weak acid HA(aq) with its sodium salt NaA(aq).	When OH <sup>-</sup> (aq) or H <sup>+</sup> (aq) ions are added to a buffer solution, the added amounts of OH <sup>-</sup> (aq) or H <sup>+</sup> (aq) ions are removed through the reactions; OH <sup>-</sup> (aq) + HA(aq) → A <sup>-</sup> (aq) + H <sub>2</sub> O(l) and H <sup>+</sup> (aq) + A <sup>-</sup> (aq) → HA(aq) respectively.
43.	Essential oils can be extracted from plants by steam distillation at a temperature below 100 °C.	At the temperature at which a mixture of essential oil and water boils, the total vapour pressure of the system is less than the atmospheric pressure.
44.	At a given temperature and pressure the molar volumes of two different ideal gases are different from each other.	At 0 °C temperature and 1 atm pressure, the molar volume of an ideal gas is 22.4 dm <sup>3</sup> mol <sup>-1</sup> .
45.	All compounds having a C=C bond show diastereoisomerism.	Any two isomers which are not mirror images of each other are diastereoisomers.
46.	Hydrogenation of benzene is more difficult than hydrogenation of alkenes.	Addition of hydrogen to benzene results in the loss of aromatic stabilization.
47.	The reaction that takes place between SO <sub>3</sub> gas and water in the production of sulphuric acid is endothermic.	SO <sub>3</sub> gas reacts with concentrated H <sub>2</sub> SO <sub>4</sub> to give oleum.
48.	Reaction between ammonia and an alkylhalide gives a mixture of primary, secondary and tertiary amines and a quaternary ammonium salt.	Primary, secondary and tertiary amines can react as nucleophiles.
49.	If P + Q → R is a first order reaction with respect to the reactant P, the graph of rate against concentration of P gives a straight line passing through the origin.	Initial rate of a first order reaction is independent of the concentration of reactant(s).
50.	On a sunny day, strong photochemical smog can be seen in a city with heavy traffic congestion.	Photochemical smog is caused entirely by scattering of solar radiation by small particles and water droplets that are emitted by vehicle exhaust systems.

\*\*\*

I See nava nine

**ශ්‍රී ලංකා විභාග දෙපාර්තමේන්තුව**  
 Department of Examinations – Sri Lanka  
**අ.පො.ස.(උ.පෙළ)විභාගය/G.C.E. (A/L)- 2020**  
**නව නිර්දේශය/ New Syllabus**

විෂය අංකය  
Subject No

02

විෂය  
Subject

**Chemistry**

**ලකුණු දීමේ පටිපාටිය/Marking Scheme**  
**I පත්‍රය/Paper I**

ප්‍රශ්න අංකය Question No.	පිළිතුරු අංකය Answer No.	ප්‍රශ්න අංකය Question No.	පිළිතුරු අංකය Answer No.	ප්‍රශ්න අංකය Question No.	පිළිතුරු අංකය Answer No.	ප්‍රශ්න අංකය Question No.	පිළිතුරු අංකය Answer No.	ප්‍රශ්න අංකය Question No.	පිළිතුරු අංකය Answer No.
01.	5	11.	2	21.	3	31.	5	41.	4
02.	3	12.	3	22.	4 or 5	32.	2	42.	1 or 2
03.	4	13.	3	23.	1	33.	5	43.	3
04.	2	14.	2	24.	ALL	34.	4 or 5	44.	4
05.	ALL	15.	ALL	25.	ALL	35.	1	45.	5
06.	1	16.	3	26.	1	36.	5	46.	1
07.	2	17.	1	27.	5	37.	3 or 5	47.	4
08.	3	18.	1	28.	5	38.	4	48.	1
09.	4	19.	2	29.	4	39.	4	49.	3
10.	2	20.	2	30.	2	40.	5	50.	3

**විශේෂ උපදෙස්/ Special Instructions:**

එක් පිළිතුරකට ලකුණු 01 බැගින්/ 01 Mark for each question

මුළු ලකුණු/ Total Marks 01 × 50 = 50

**PART A – STRUCTURED ESSAY**

Answer all four questions on this paper itself. (Each question carries 10 marks.)

1. (a) Write the answers to the questions given below on the dotted lines.

- (i) Of the three ions  $\text{Na}^+$ ,  $\text{Mg}^{2+}$  and  $\text{F}^-$ , which one has the **smallest** ionic radius? .....  $\text{Mg}^{2+}$  .....
- (ii) Of the three elements C, N and O, which one has the **highest** second ionization energy? ..... O .....
- (iii) Of the three compounds  $\text{H}_2\text{O}$ ,  $\text{HOCl}$  and  $\text{OF}_2$ , which one has the **most** electronegative oxygen atom? .....  $\text{OF}_2$  .....
- (iv) Of the three elements Be, C and N, which one will liberate energy when an electron is added to its atom [ $\text{Y}(\text{g}) + e \rightarrow \text{Y}^-(\text{g})$ ;  $\text{Y} = \text{Be}, \text{C}, \text{N}$ ] in the gaseous state? ..... C .....
- (v) Of the three ionic compounds  $\text{NaF}$ ,  $\text{KF}$  and  $\text{KBr}$ , which one has the **highest** solubility in water? .....  $\text{KF}$  or  $\text{KBr}$  .....
- (vi) Of the three compounds  $\text{HCHO}$ ,  $\text{CH}_3\text{F}$  and  $\text{H}_2\text{O}_2$ , which one has the **strongest** intermolecular forces? .....  $\text{H}_2\text{O}_2$  .....

(04 marks X 6 = 24)

**1(a): 24 marks**

(b) (i) Draw the **most** acceptable Lewis structure for the ion,  $\text{N}_2\text{O}_3^{2-}$ . Its skeleton is given below.



(ii) Draw **three** more Lewis structures (resonance structures) for this ion. Indicate the relative stabilities of the structures drawn by you, when compared with the most acceptable structure drawn in (i) above, by writing 'less stable' or 'unstable' under these structures.

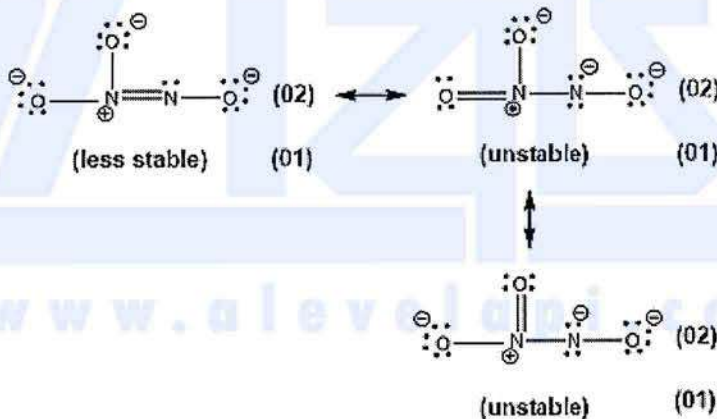

(iii) Complete the given table based on the Lewis structure and its labelled skeleton given below.



	N <sup>1</sup>	N <sup>2</sup>	O <sup>3</sup>	C <sup>4</sup>
VSEPR pairs around the atom	3	3	4	2
electron pair geometry around the atom	trigonal planar	trigonal planar	tetrahedral	linear
shape around the atom	trigonal planar	angular/ V	angular/ V	linear
hybridization of the atom	$sp^2$	$sp^2$	$sp^3$	$sp$

(01 X 16 = 16)

- Parts (iv) to (vii) are based on the Lewis structure given in part (iii) above. Labelling of atoms is as in part (iii).

(iv) Identify the atomic/hybrid orbitals involved in the formation of  $\sigma$  bonds between the two atoms given below.

I. Cl—N <sup>1</sup>	Cl	..... 3p OR sp <sup>3</sup> .....	N <sup>1</sup>	..... sp <sup>2</sup> .....
II. N <sup>1</sup> —O	N <sup>1</sup>	..... sp <sup>2</sup> .....	O	..... 2p OR sp <sup>3</sup> .....
III. N <sup>1</sup> —N <sup>2</sup>	N <sup>1</sup>	..... sp <sup>2</sup> .....	N <sup>2</sup>	..... sp <sup>2</sup> .....
IV. N <sup>2</sup> —O <sup>3</sup>	N <sup>2</sup>	..... sp <sup>2</sup> .....	O <sup>3</sup>	..... sp <sup>3</sup> .....
V. O <sup>3</sup> —C <sup>4</sup>	O <sup>3</sup>	..... sp <sup>3</sup> .....	C <sup>4</sup>	..... sp .....
VI. C <sup>4</sup> —N	C <sup>4</sup>	..... sp .....	N	..... 2p OR sp .....

**(01 X 12 = 12)**

(v) Identify the atomic orbitals involved in the formation of  $\pi$  bonds between the two atoms given below.

I. N <sup>1</sup> —N <sup>2</sup>	N <sup>1</sup>	..... N <sup>1</sup> , 2p .....	N <sup>2</sup>	..... N <sup>2</sup> , 2p .....
II. C <sup>4</sup> —N	C <sup>4</sup>	..... C <sup>4</sup> , 2p .....	N	..... N, 2p .....
	C <sup>4</sup>	..... C <sup>4</sup> , 2p .....	N	..... N, 2p .....

**(01 X 6 = 06)**

(vi) State the approximate bond angles around N<sup>1</sup>, N<sup>2</sup>, O<sup>3</sup> and C<sup>4</sup> atoms.

N <sup>1</sup> .....120° ± 1,	N <sup>2</sup> .....115° -118°	O <sup>3</sup> .....104° ± 1,	C <sup>4</sup> .....180° ± 1
-------------------------------	--------------------------------	-------------------------------	------------------------------

**(01 X 4 = 04)**

(vii) Arrange the atoms N<sup>1</sup>, N<sup>2</sup>, O<sup>3</sup> and C<sup>4</sup> in the **increasing** order of electronegativity.



**1(b): 56 marks**

(c) Consider the following information.

- I. The atoms **A** and **B** combine to form a heterodiatomic molecule **AB** that has a  $\sigma$  bond. This is represented as **A—B**.
- II. The electronegativity of **A** is less than that of **B** ( $X_A < X_B$ ).  
X = electronegativity of the atom
- III. The inter-nuclear distance between **A** and **B** atoms ( $d_{A-B}$ ) of the **AB** molecule is given by the following equation.

$$d_{A-B} = r_A + r_B - c(X_B - X_A)$$

$$r = \text{atomic radius, } c = 9 \text{ pm}$$

**Note:** d and r are measured in picometres (pm). (1 pm = 10<sup>-12</sup> m)

Based on the above information, answer the following questions.

(i) What is the name used to identify the type of  $\sigma$  bond between **A** and **B**?

Polar covalent bond..... **(03)**

(ii) Show how fractional charges ( $\delta^+$  and  $\delta^-$ ) are located in the molecule **AB**.

A<sup>δ+</sup>—B<sup>δ-</sup>..... **(03)**

(iii) Write the equation to calculate the dipole moment ( $\mu$ ) of molecule **AB** and show its direction.

$\mu = d_{AB} \times \delta$ , OR  $\mu = qr$ ,  $\xrightarrow{\quad}$  A—B OR A—B  $\xrightarrow{\quad}$  **(01 + 01)**

(iv) Calculate the percentage of ionic character of the H-F bond in the HF molecule using the data given below.

Inter-nuclear distance of H<sub>2</sub> (d<sub>H-H</sub>) = 74 pm      Electronegativity of F = 4.0  
 Inter-nuclear distance of F<sub>2</sub> (d<sub>F-F</sub>) = 144 pm      Dipole moment of HF = 6.0 × 10<sup>-30</sup> C m  
 Electronegativity of H = 2.1      Charge of an electron = 1.6 × 10<sup>-19</sup> C

$$\mu = d_{HF} \times \delta, \quad H^{\delta+} - F^{\delta-}$$

$$r_H = \frac{d_{H_2}}{2} = \frac{74}{2} = 37 \text{ pm} \quad (02)$$

$$r_F = \frac{d_{F_2}}{2} = \frac{144}{2} = 72 \text{ pm} \quad (02)$$

$$\text{Therefore, } d_{HF} = 37 + 72 - 9(4.0 - 2.1) \quad (01)$$

$$= 109 - 9 \times 1.9$$

$$= 91.9 \text{ pm} \quad (02)$$

$$\mu = d_{HF} \times \delta, \quad 6.0 \times 10^{-30} \text{ C m} = \delta \times 91.9 \times 10^{-12} \text{ m} \quad (01)$$

$$\delta = \frac{6.0 \times 10^{-30}}{91.9 \times 10^{-12}} = 0.65 \times 10^{-19} \quad (02)$$

$$\% \text{ Ionic character} = \frac{0.65 \times 10^{-19}}{1.6 \times 10^{-19}} \times 100 \quad (01)$$

$$= 40.6\% \quad (01)$$

OR

$$r_H = \frac{d_{H_2}}{2} = \frac{74}{2} = 37 \text{ pm} \quad (02)$$

$$r_F = \frac{d_{F_2}}{2} = \frac{144}{2} = 72 \text{ pm} \quad (02)$$

$$\text{Therefore, } d_{HF} = 37 + 72 - 9(4.0 - 2.1) \quad (01)$$

$$= 109 - 9 \times 1.9$$

$$= 91.9 \text{ pm} \quad (02)$$

$$\mu_{\text{ionic}} = 1.6 \times 10^{-19} \text{ C} \times 91.9 \times 10^{-12} \text{ m}$$

$$= 147.04 \times 10^{-31} \text{ C m} \quad (03)$$

$$\% \text{ Ionic character} = \frac{6 \times 10^{-30}}{147.04 \times 10^{-31}} \times 100 \quad (01)$$

$$= 40.8\% \quad (01)$$

2. (a) A, B, C and D are chlorides of p-block elements. These elements have atomic numbers less than 20. A description of the products (P<sub>1</sub> - P<sub>9</sub>) formed when A is reacted with a limited amount of water and B, C and D are reacted with excess water are given below.

Compound	Description of products
A	P <sub>1</sub> a compound with a covalent network structure
	P <sub>2</sub> a strong monobasic acid
B	P <sub>3</sub> a gas that turns red litmus blue
	P <sub>4</sub> a compound with bleaching properties
C	P <sub>5</sub> a tribasic acid
	P <sub>6</sub> a strong monobasic acid
D	P <sub>7</sub> a gas that turns acidic KMnO <sub>4</sub> solution colourless
	P <sub>8</sub> a colloidal solid
	P <sub>9</sub> a strong monobasic acid

(i) Identify A, B, C and D (give the chemical formulae).

A: SiCl<sub>4</sub>      B: NCl<sub>3</sub>      C: PCl<sub>5</sub>      D: SCl<sub>2</sub>      (04 x 4)

(ii) Give balanced chemical equations for the reactions of A, B, C and D with water to give products P<sub>1</sub> to P<sub>9</sub>.

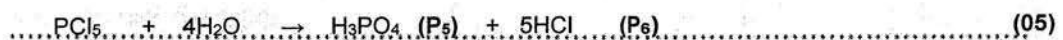
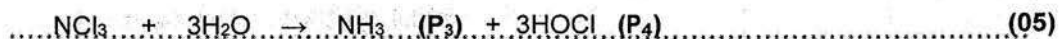
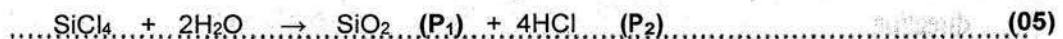

Note: Award marks if correct balanced equations are given.



(iii) Write balanced chemical equations for the following reactions.

I. P<sub>1</sub> with NaOH(aq)

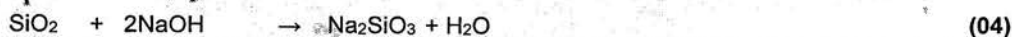

II. P<sub>3</sub> with Mg



III. P<sub>7</sub> with acidic K<sub>2</sub>Cr<sub>2</sub>O<sub>7</sub>

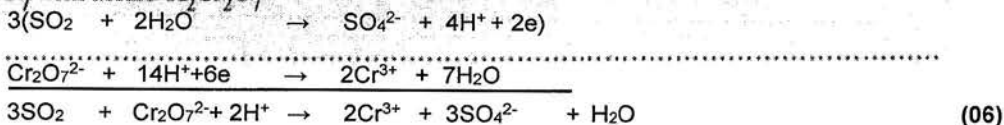

If only half reactions are given – part marks (02 + 02)

2(a): 50 marks

(b) A student is provided with bottles labelled P, Q, R, S, T and U containing aqueous solutions of Al<sub>2</sub>(SO<sub>4</sub>)<sub>3</sub>, H<sub>2</sub>SO<sub>4</sub>, Na<sub>2</sub>S<sub>2</sub>O<sub>3</sub>, BaCl<sub>2</sub>, Pb(Ac)<sub>2</sub> and KOH (not in order). Some useful observations for their identification on mixing two solutions at a time are given below. (Ac - Acetate ion)

	Solutions mixed	Observations
I	T + R	a clear colourless solution
II	P + R	a white precipitate
III	T + S	a gelatinous white precipitate
IV	U + R	a white precipitate
V	P + Q	a white precipitate, turns black on heating
VI	P + U	a white precipitate, dissolves on heating

(i) Identify P to U.

P: Pb(Ac)<sub>2</sub> ..... Q: Na<sub>2</sub>S<sub>2</sub>O<sub>3</sub> ..... R: H<sub>2</sub>SO<sub>4</sub> .....  
 S: Al<sub>2</sub>(SO<sub>4</sub>)<sub>3</sub> OR KOH ..... T: KOH OR Al<sub>2</sub>(SO<sub>4</sub>)<sub>3</sub> ..... U: BaCl<sub>2</sub> .....

(05 X 6 = 30)

(ii) Give balanced chemical equations for each of the reactions I to VI.

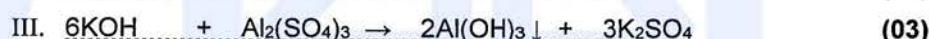
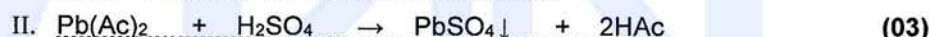
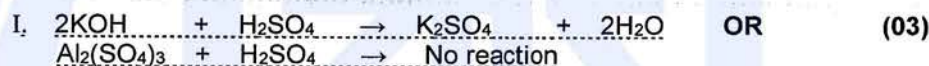

V. Formation of white ppt

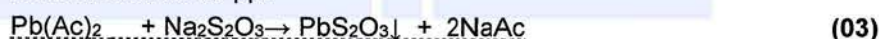

Turning black on heating

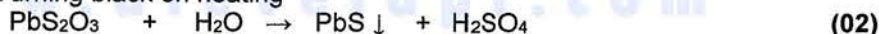

Note: Precipitates have to be shown by ↓ or as (s). If not, deduct (01) mark.

2(b): 50 marks

3. (a) A saturated aqueous solution of a sparingly soluble salt AB<sub>2</sub>(s) was prepared by stirring an excess amount of AB<sub>2</sub>(s) in 1.0 dm<sup>3</sup> of distilled water at 25 °C. The amount of A<sup>2+</sup>(aq) ions present in this saturated aqueous solution was found to be 2.0 × 10<sup>-3</sup> mol.

(i) Write the equilibrium related to the dissolution of AB<sub>2</sub>(s) in the above system at 25 °C.



(ii) Write the expression for the equilibrium constant for the equilibrium written in (i) above at 25 °C.

$$K_{sp} = [\text{A}^{2+}(\text{aq})][\text{B}^{-}(\text{aq})]^2 \quad (05)$$

$$K_c = \frac{[\text{A}^{2+}(\text{aq})][\text{B}^{-}(\text{aq})]^2}{[\text{AB}_2(\text{s})]}$$

Note: If only K<sub>c</sub> is given award (03 marks)

(iii) Calculate the value of the equilibrium constant stated in (ii) above at 25 °C.

$$[A^{2+}(aq)] = 2.0 \times 10^{-3} \text{ mol dm}^{-3} \quad (04+01)$$

$$[B^{-}(aq)] = 2[A^{2+}(aq)] = 4.0 \times 10^{-3} \text{ mol dm}^{-3} \quad (04+01)$$

$$K_{sp} = 2.0 \times 10^{-3} \text{ mol dm}^{-3} \times (4.0 \times 10^{-3} \text{ mol dm}^{-3})^2 \quad (05)$$

$$K_{sp} = 3.2 \times 10^{-8} \text{ mol}^3 \text{ dm}^{-9} \quad (05)$$

(iv) Another saturated aqueous solution of AB<sub>2</sub> was prepared by stirring an excess amount of AB<sub>2</sub>(s) in 2.0 dm<sup>3</sup> of distilled water at 25 °C. Giving reasons, predict the value of the equilibrium constant for this system.

$$K_{sp} = 3.2 \times 10^{-8} \text{ mol}^3 \text{ dm}^{-9} \quad (05)$$

K<sub>sp</sub> is a constant at constant temperature (05)

and does not depend on the volume (05)

(v) A small amount of the strong electrolyte NaB(s) is added to a saturated aqueous solution of AB<sub>2</sub> at 25 °C. Giving reasons, predict whether the concentration of A<sup>2+</sup>(aq) is increased or decreased.

Common-ion B<sup>-</sup>(aq) is added (05)

∴ More AB<sub>2</sub>(s) is formed to keep the K<sub>sp</sub> constant or reverse reaction takes place (05)

[A<sup>2+</sup>(aq)], *decreases* (05)

3(a): 60 marks

(b) In an aqueous solution, propanoic acid (C<sub>2</sub>H<sub>5</sub>COOH) ionizes as given below.



At 25 °C, K<sub>a</sub> (propanoic acid) = 1.0 × 10<sup>-5</sup>

(i) Write the expression for the equilibrium constant for the above reaction at 25 °C.

$$K_a = \frac{[C_2H_5COO^{-}(aq)][H_3O^{+}(aq)]}{[C_2H_5COOH(aq)]} \quad (05)$$

(ii) 100.0 cm<sup>3</sup> of an aqueous solution of C<sub>2</sub>H<sub>5</sub>COOH(aq) was prepared by dissolving 0.74 cm<sup>3</sup> of C<sub>2</sub>H<sub>5</sub>COOH in distilled water at 25 °C. Calculate the pH of the solution at 25 °C. (C = 12; O = 16; H = 1; consider the density of C<sub>2</sub>H<sub>5</sub>COOH as 1.0 g cm<sup>-3</sup>)

$$\text{mass of } C_2H_5COOH(aq) = 0.74 \text{ cm}^3 \times 1.00 \text{ g cm}^{-3} = 0.74 \text{ g}$$

$$\text{moles of } C_2H_5COOH(aq) \text{ in } 100 \text{ cm}^3 = 0.74 \text{ g} / 74 \text{ g mol}^{-1} = 0.01 \text{ mol} \quad (05)$$

$$\therefore [C_2H_5COOH(aq)] = 0.10 \text{ mol dm}^{-3} \quad (05)$$

Consider the equilibrium:

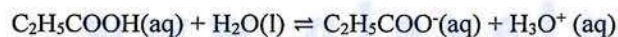

<i>Initial</i>	0.10	0	0	<i>mol dm<sup>-3</sup></i>
<i>Change</i>	-x	x	x	<i>mol dm<sup>-3</sup></i>
<i>At eqm</i>	0.10-x	x	x	<i>mol dm<sup>-3</sup></i>

(05)

$$K_a = \frac{[C_2H_5COO^{-}(aq)][H_3O^{+}(aq)]}{[C_2H_5COOH(aq)]} = \frac{x \cdot x}{0.10 - x} = 1.0 \times 10^{-5} \quad (02)$$

$$\frac{x^2}{0.10} = 1.0 \times 10^{-5} \quad (0.10 - x \sim 0.1) \quad (03)$$

$$x^2 = 1.0 \times 10^{-6} \quad (05)$$

$$x = 1.0 \times 10^{-3} \text{ mol dm}^{-3} = [H_3O^{+}(aq)] \quad (05)$$

$$pH = -\log [H_3O^{+}(aq)] = 1.0 \times 10^{-3} \quad (05)$$

$$pH = 3.0 \quad (05)$$

Note : Students may take -log of both sides of  $K_a = \frac{[C_2H_5COO^{-}(aq)][H_3O^{+}(aq)]}{[C_2H_5COOH(aq)]}$  and calculate pH.

Award marks appropriately.

3(b): 40 marks

4. (a) A, B, C and D are structural isomers having the molecular formula C<sub>6</sub>H<sub>10</sub>. None of them show optical isomerism. All four isomers, A, B, C and D when treated with HgSO<sub>4</sub>/dil. H<sub>2</sub>SO<sub>4</sub> give products which react with 2,4-dinitrophenylhydrazine (2,4-DNP) to give coloured precipitates. Only A gives a precipitate with ammonical AgNO<sub>3</sub>. A has only one position isomer, which is B. B is a chain isomer of C. C reacts with HgSO<sub>4</sub>/dil. H<sub>2</sub>SO<sub>4</sub> to give two products E and F. D reacts with HgSO<sub>4</sub>/dil. H<sub>2</sub>SO<sub>4</sub> to give only one product, which is E.

(i) Draw the structures of A, B, C, D, E and F in the boxes given below.

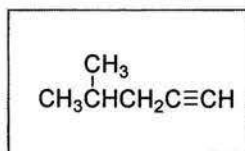

A

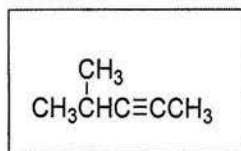

B

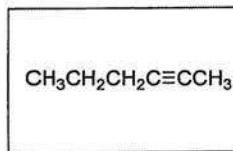

C

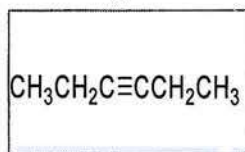

D

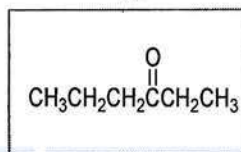

E

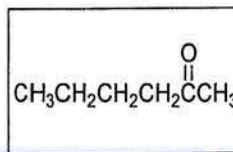

F

(06 x 6 = 36)

- (ii) Which of the compounds A, B, C and D gives a product that does not show diastereoisomerism when reacted separately with H<sub>2</sub> / Pd-BaSO<sub>4</sub> / quinoline?

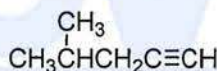

(05)

or Appropriate letter (A, B, C or D) identifying the correct structure

- (iii) Draw, in the box given below, the structure of the product G obtained when A is reacted with excess HBr.

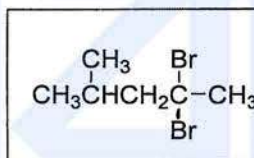

G

(05)

- (iv) Draw the structures of products X and Y obtained in the following reactions of E, in the appropriate boxes.

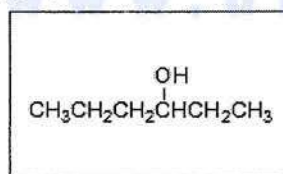

X

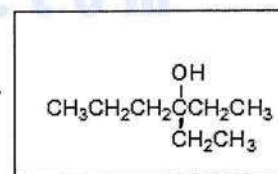
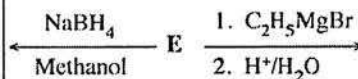

Y

(05 x 2 = 10)

Name a test to distinguish between X and Y.

Lucas test or  
anh. ZnCl<sub>2</sub> / conc. HCl or  
H<sup>+</sup>/K<sub>2</sub>Cr<sub>2</sub>O<sub>7</sub> or  
H<sup>+</sup>/KMnO<sub>4</sub>

(04)

4(a): 60 marks

Sequence 1:

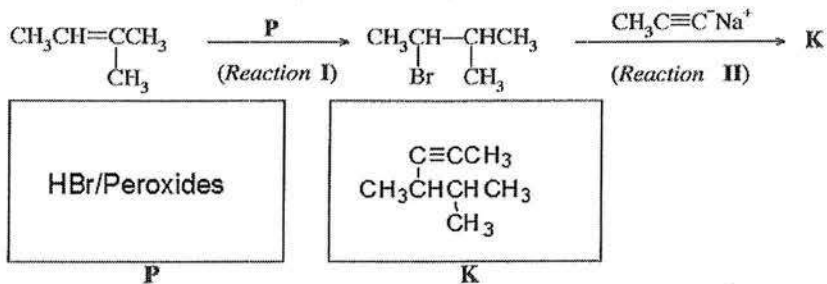

Sequence 2:

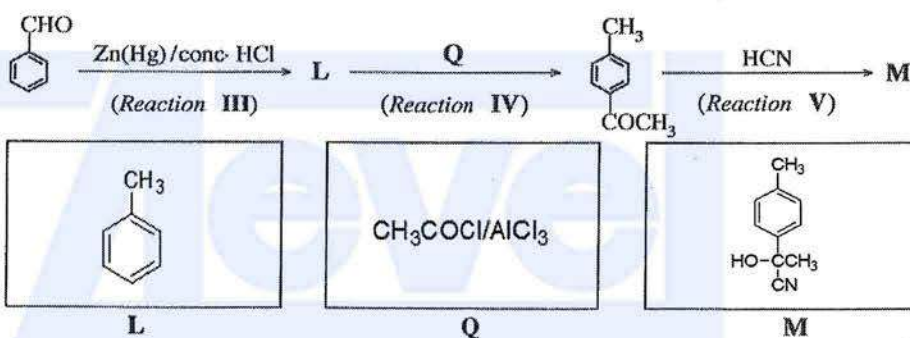

Sequence 3:

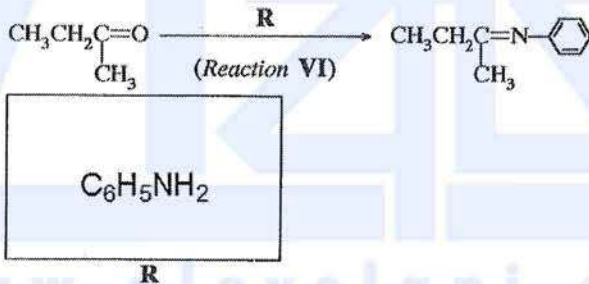

Compounds/reagents (05 x 6 = 30)

(ii) Selecting from the reactions I–VI, give one (01) example for each of the following types of reactions.

Nucleophilic addition ..... Reaction V .....

Nucleophilic substitution ..... Reaction II .....

Reactions (05 x 2 = 10)

4(b): 40 marks

## PART B – ESSAY

5. (a) A compound  $XY_2Z_2(g)$  undergoes dissociation when heated to temperatures above 300 K as given below.

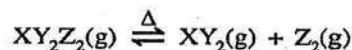

A sample of 7.5 g of  $XY_2Z_2(g)$  was placed in an evacuated 1.00 dm<sup>3</sup> rigid-closed container and the temperature was raised to 480 K.

Molar mass of  $XY_2Z_2(g)$  is 150 g mol<sup>-1</sup>. Use the approximate value of 4000 J mol<sup>-1</sup> for  $RT$  at 480 K. Assume ideal gas behaviour for all gases.

- (i) Calculate the number of moles of  $XY_2Z_2(g)$  in the container before dissociation.

$$7.5 \text{ g} / 150 \text{ g mol}^{-1} = 5.0 \times 10^{-2} \text{ mol} \quad (05)$$

5(a) (i): 05 marks

- (ii) When the above system reaches equilibrium at 480 K, the total number of moles in the container was found to be  $7.5 \times 10^{-2}$  mol. Calculate the number of moles of  $XY_2Z_2(g)$ ,  $XY_2(g)$  and  $Z_2(g)$  in the equilibrium mixture at 480 K.

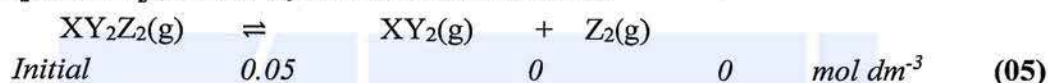

$$\text{Total number of moles} = 0.05 + x = 7.5 \times 10^{-2} \text{ mol} \quad (05)$$

$$x = 2.5 \times 10^{-2} \text{ mol} \quad (05)$$

$$XY_2(g) = Z_2(g) = 2.5 \times 10^{-2} \text{ mol} \quad (05)$$

$$XY_2Z_2(g) = 5.0 \times 10^{-2} \text{ mol} - 2.5 \times 10^{-2} \text{ mol} = 2.5 \times 10^{-2} \text{ mol} \quad (05)$$

5(a) (ii): 30 marks

- (iii) Calculate the equilibrium constant  $K_c$  for the above reaction at 480 K.

$$K_c = \frac{[XY_2(g)][Z_2(g)]}{[XY_2Z_2(g)]} \quad (05)$$

$$\text{Concentration} = 2.5 \times 10^{-2} \text{ mol dm}^{-3} \quad (05)$$

$$K_c = \frac{2.5 \times 10^{-2} \text{ mol dm}^{-3} \times 2.5 \times 10^{-2} \text{ mol dm}^{-3}}{2.5 \times 10^{-2} \text{ mol dm}^{-3}} \quad (05)$$

$$K_c = 2.5 \times 10^{-2} \text{ mol dm}^{-3} \quad (05)$$

5(a) (iii): 20 marks

- (iv) Calculate  $K_p$  for the equilibrium at 480 K.

$$K_p = K_c (RT)^{\Delta n} \quad (05)$$

$$\Delta n = 1 \quad (05)$$

$$K_p = 2.5 \times 10^{-2} \text{ mol dm}^{-3} \times 4 \times 10^3 \text{ J mol}^{-1} \quad (05)$$

$$K_p = 1.0 \times 10^5 \text{ Pa} \quad (05)$$

**iv. Alternative:**Total number of moles at equilibrium =  $7.5 \times 10^{-2}$  mol

$$P_{\text{Total}} = (7.5 \times 10^{-2} \text{ mol} \times 4 \times 10^3 \text{ J mol}^{-1}) / 1.0 \times 10^{-3} \text{ m}^3 = 3.0 \times 10^5 \text{ Pa}$$

Number of moles of  $\text{XY}_2\text{Z}_2(\text{g}) = \text{XY}_2(\text{g}) = \text{Z}_2(\text{g}) = 2.5 \times 10^{-2}$  molMole fractions of  $\text{XY}_2\text{Z}_2(\text{g}) = \text{XY}_2(\text{g}) = \text{Z}_2(\text{g}) = 1/3$ 

$$P_i = X_i P_{\text{total}}$$

$$P_{\text{XY}_2\text{Z}_2(\text{g})} = P_{\text{XY}_2(\text{g})} = P_{\text{Z}_2(\text{g})} = 1.0 \times 10^5 \text{ Pa}$$

$$K_p = [P_{\text{XY}_2(\text{g})} P_{\text{Z}_2(\text{g})}] / P_{\text{XY}_2\text{Z}_2(\text{g})} = 1.0 \times 10^5 \text{ Pa}$$

5(a): 75 marks

- (b) For the reaction  $\text{XY}_2\text{Z}_2(\text{g}) \rightarrow \text{XY}_2(\text{g}) + \text{Z}_2(\text{g})$  described in (a), Gibbs free energies ( $G$ ) at 480 K for  $\text{XY}_2\text{Z}_2(\text{g})$ ,  $\text{XY}_2(\text{g})$  and  $\text{Z}_2(\text{g})$  are  $-60 \text{ kJ mol}^{-1}$ ,  $-76 \text{ kJ mol}^{-1}$  and  $-30 \text{ kJ mol}^{-1}$ , respectively.

- (i) Calculate  $\Delta G$  (in  $\text{kJ mol}^{-1}$ ) for the reaction at 480 K.



$$\begin{aligned} \Delta G_{\text{rxn}} &= G_{\text{products}} - G_{\text{reactants}} && (05) \\ &= (-76 + (-30)) - (-60) = -46 \text{ kJ mol}^{-1} && (04+01) \end{aligned}$$

Note: No marks if  $\Delta G_{\text{rxn}}^0$  is written.

5(b) (i): 10 marks

- (ii) The magnitude of  $\Delta S$  of the above reaction is  $150 \text{ J K}^{-1} \text{ mol}^{-1}$  at 480 K. Calculate  $\Delta H$  for the reaction at 480 K by using the appropriate sign ( $-$  or  $+$ ) of  $\Delta S$ .

$\Delta S$  must be positive (number of gaseous moles is higher in products) (05)

5(b) (ii): 05 marks

- (iii) By using the sign ( $-$  or  $+$ ) of  $\Delta H$  obtained in (ii), explain whether this reaction is exothermic or endothermic.

$$\Delta G = \Delta H - T \Delta S \quad (05)$$

$$-46 \text{ kJ mol}^{-1} = \Delta H - 480 \text{ K} \times 150 \times 10^{-3} \text{ kJ K}^{-1} \text{ mol}^{-1}$$

$$\Delta H = -46 \text{ kJ mol}^{-1} + 72 \text{ kJ mol}^{-1} \quad (04+01)$$

$$\Delta H = +26 \text{ kJ mol}^{-1} \quad (04+01)$$

5(b) (iii): 15 marks

- (iv) Deduce the enthalpy difference for the formation of  $\text{XY}_2\text{Z}_2(\text{g})$  from  $\text{XY}_2(\text{g})$  and  $\text{Z}_2(\text{g})$  at 480 K.

The reaction is endothermic (05)

because  $\Delta H$  is positive (05)

5(b) (iv): 10 marks

- (v) If the bond enthalpy of the X-Z bond in  $XY_2Z_2(g)$  is  $+250 \text{ kJ mol}^{-1}$ , calculate the bond enthalpy of the Z-Z bond.

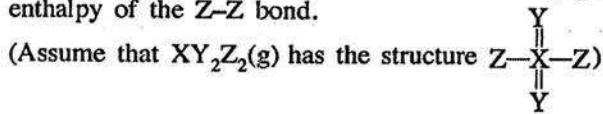

$$\Delta H = -26 \text{ kJ mol}^{-1} \quad (09 + 01)$$

5(b) (v): 10 marks

- (vi) If liquid  $XY_2Z_2$  is used instead of gaseous  $XY_2Z_2$ , giving reasons, explain whether the value of  $\Delta H$  obtained for the reaction  $XY_2Z_2(l) \rightarrow XY_2(g) + Z_2(g)$  is equal to, or higher or lower than  $\Delta H$  obtained in (ii).

$$\Delta H_{rxn} = \Delta H_{bonds \text{ formed}} - \Delta H_{bonds \text{ broken}} \quad (05)$$

$$\Delta H_{rxn} = \Delta H_{Z-Z} - 2 \Delta H_{X-Z} \quad (05)$$

$$26 \text{ kJ mol}^{-1} = \Delta H_{Z-Z} - 2 \times 250 \text{ kJ mol}^{-1}$$

$$\Delta H_{Z-Z} = 526 \text{ kJ mol}^{-1} \quad (04+01)$$

(OR students may solve through an appropriate thermo cycle)

Higher (05)

It is necessary to supply energy to convert liquid to gas first (05)

(or  $XY_2Z_2(l) \rightarrow XY_2Z_2(g)$  needs an extra energy)

5(b) (vi): 25 marks

5(b): 75 marks

6. (a) Consider the reaction given below occurring in a closed container at a given temperature  $T$ .



- (i) Write **three** expressions for the rate of reaction relevant to each of the compounds appearing in the reaction.

$$Rate = -\frac{\Delta[N_2O_5(g)]}{2 \Delta t} = \frac{\Delta[NO_2(g)]}{4 \Delta t} = \frac{\Delta[O_2(g)]}{\Delta t} \quad (05)$$

6(a) (i): 05 marks

- (ii) This reaction was carried out at temperature  $T$  with an initial concentration of  $0.10 \text{ mol dm}^{-3}$  of  $N_2O_5(g)$ . It was found that 40% of the initial amount was decomposed after a period of 400 s.

1. Calculate the average rate of decomposition of  $N_2O_5(g)$  in this time interval.

$$\text{Decomposed amount} = 0.10 \text{ mol dm}^{-3} \times 40/100 = 4.0 \times 10^{-2} \text{ mol dm}^{-3} \quad (05)$$

$$\text{Remaining concentration after 400 s} = 6.0 \times 10^{-2} \text{ mol dm}^{-3} \quad (05)$$

$$\text{Average Rate} = \frac{-(0.06 - 0.10) \text{ mol dm}^{-3}}{(400-0)\text{s}} = 1.0 \times 10^{-4} \text{ mol dm}^{-3} \text{ s}^{-1} \quad (05)$$

II. Calculate average rates of formation of  $\text{NO}_2(\text{g})$  and  $\text{O}_2(\text{g})$ .

$$\frac{\Delta[\text{N}_2\text{O}_5(\text{g})]}{2 \Delta t} = \frac{\Delta[\text{NO}_2(\text{g})]}{4 \Delta t}$$

$$\frac{\Delta[\text{NO}_2(\text{g})]}{4 \Delta t} = 2.0 \times 10^{-4} \text{ mol dm}^{-3} \text{ s}^{-1} \quad (02)$$

$$\frac{\Delta[\text{O}_2(\text{g})]}{\Delta t} = \frac{\Delta[\text{N}_2\text{O}_5(\text{g})]}{2 \Delta t} = 5.0 \times 10^{-5} \text{ mol dm}^{-3} \text{ s}^{-1} \quad (03)$$

6(a) (ii): 20 marks

(iii) In another experiment, initial rates were measured for this reaction at 300 K and the results are given below.

$[\text{N}_2\text{O}_5(\text{g})] / \text{mol dm}^{-3}$	0.01	0.02	0.03
Initial rate / $\text{mol dm}^{-3} \text{ s}^{-1}$	$6.930 \times 10^{-5}$	$1.386 \times 10^{-4}$	$2.079 \times 10^{-4}$

Derive the rate law for the reaction at 300 K.

When the concentration were increased two and three times, rate increased two and three times, respectively. (05)

∴ Reaction is first order (05)

∴ Rate law : Rate =  $k [\text{N}_2\text{O}_5(\text{g})]$  (05)

(OR  $R_1/R_2 = 1/2$  ∴∴∴ reaction is first order)

6(a) (iii): 15 marks

(iv) Another experiment was carried out at 300 K with an initial concentration of  $0.64 \text{ mol dm}^{-3}$  of  $\text{N}_2\text{O}_5(\text{g})$ . It was found that the concentration of  $\text{N}_2\text{O}_5(\text{g})$  which remained after a period of 500 s was  $2.0 \times 10^{-2} \text{ mol dm}^{-3}$ .

I. Calculate the half-life ( $t_{1/2}$ ) of the reaction at 300 K.

$$\text{Order of concentration change} = 0.64/2.0 \times 10^{-2} = 32 = (2)^5 \quad (05)$$

$$\therefore \text{Fraction of initial } \text{N}_2\text{O}_5(\text{g}) = (1/2)^5 \quad (05)$$

That is, 5 half-lives passed to reach this concentration (05)

$$\therefore t_{1/2} = 500 \text{ s} / 5 = 100 \text{ s} \quad (05)$$

II. Calculate the rate constant of the reaction at 300 K.

from iii,

$$\text{Rate} = k [\text{N}_2\text{O}_5(\text{g})] = 6.93 \times 10^{-5} \text{ mol dm}^{-3} \text{ s}^{-1} = k \cdot 0.01 \text{ mol dm}^{-3} \quad (05)$$

$$k = 6.93 \times 10^{-3} \text{ s}^{-1} \quad (04+01)$$

**OR**

Reaction is first order

$$\text{For first order reaction: } t_{1/2} = 0.693 / k \quad (05)$$

$$\therefore k = 0.693 / 100 \text{ s} = 6.93 \times 10^{-3} \text{ s}^{-1} \quad (05)$$

6(a) (iv): 30 marks



(v) This reaction proceeds through a mechanism involving the following elementary steps.

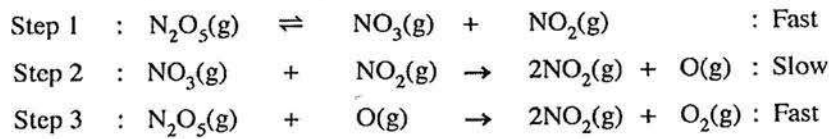

Show that the above mechanism is consistent with the rate law of the reaction. (8.0 marks)

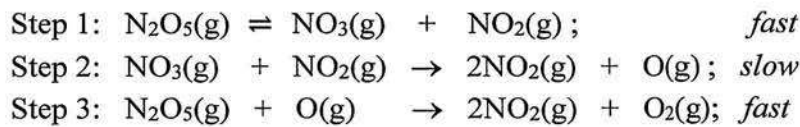

From step 2 (Slow-step);

$$\text{Rate} = k[NO_3(g)][NO_2(g)] \quad (05)$$

For step 1 (equilibrium)

$$K_{eq} = \frac{[NO_3(g)][NO_2(g)]}{[N_2O_5(g)]} \quad (05)$$

$$\text{We get, } K_{eq} [N_2O_5(g)] = [NO_3(g)][NO_2(g)]$$

$$\therefore \text{Rate} = k K_{eq} [N_2O_5(g)] = k' [N_2O_5(g)] \quad (05)$$

This is a first order reaction which follows the rate law derived (05)

6(a) (v): 20 marks

6(a): 90 marks

(b) An ideal binary-liquid mixture was prepared by mixing two liquids of A and B in a closed evacuated container at temperature  $T$ . After establishing the equilibrium at temperature  $T$ , partial pressures of A and B in the vapour phase are  $P_A$  and  $P_B$ , respectively. At temperature  $T$ , the saturated vapour pressures of A and B are  $P_A^\circ$  and  $P_B^\circ$ , respectively. Mole fractions of A and B in solution are  $X_A$  and  $X_B$ , respectively.

(i) Show that  $P_A = P_A^\circ X_A$

(Consider that the rates of vaporization and condensation are equal at equilibrium.)

Consider the above described vapor – liquid equilibrium of an ideal solution with components A and B. As the rate of evaporation equals the rate of condensation, we can write:

$$A_{(l)} \xrightleftharpoons[r_c]{r_v} A_{(g)} \dots \dots \dots (1) \quad (05)$$

$r_v$  and  $r_c$  are the rates of vaporization and condensation, respectively of the component A.

Considering (1), we can write;

$$r_v = k [A_{(l)}] = k_1 X_A \quad (05)$$

$X_A$  is the mole fraction of A in solution

Likewise,

$$r'_v = k'[A_{(g)}] = k_2 P_A \quad (05)$$

$P_A$  is the partial pressure of A in vapor phase.

At equilibrium

$$r_v = r'_v$$

$$k_2 P_A = k_1 X_A \quad (05)$$

$$\therefore P_A = \frac{k_1}{k_2} X_A \text{ or } \therefore P_A = k X_A \quad (05)$$

when  $X_A = 1$ ,  $P_A = P_A^0$  = saturated vapor pressure of A

$$\therefore k = P_A^0 \quad (05)$$

$$\therefore P_A = P_A^0 X_A \quad (05)$$

**6(b) (i): 35 marks**

(ii) In the above system at 300 K, the total pressure was  $5.0 \times 10^4$  Pa. The saturated vapour pressures of pure A and B at 300 K, are  $7.0 \times 10^4$  Pa and  $3.0 \times 10^4$  Pa, respectively.

- I. Calculate the mole fraction of A in the liquid phase of the equilibrium mixture.
- II. Calculate the vapour pressure of A in the equilibrium mixture.

$$(I) \quad P_{\text{total}} = P_A + P_B \quad (05)$$

$$= X_A P_A^0 + X_B P_B^0 = X_A P_A^0 + (1 - X_B) P_B^0 \quad (05)$$

$$\therefore X_A = \frac{P_{\text{total}} - P_B^0}{P_A^0 - P_B^0} \quad (05)$$

$$= \frac{5 \times 10^4 - 3 \times 10^4}{7 \times 10^4 - 3 \times 10^4} = \frac{1}{2} \quad (05)$$

$$(II) \quad \therefore P_A = P_A^0 X_A = \frac{1}{2} \times 7 \times 10^4 \text{ Pa} = 3.5 \times 10^4 \text{ Pa} \quad (05)$$

**6(b) (ii): 25 marks**

**6(b): 60 marks**

7. (a) (i) To compare the properties of Electrolytic and Galvanic cells, copy and complete the following table using the given terms.

Terms: anode, cathode, positive, negative, spontaneous, non-spontaneous.

		Electrolytic cell	Galvanic cell
A.	Oxidation half reaction takes place at	Anode	Anode
B.	Reduction half reaction takes place at	Cathode	cathode
C.	Sign of $E^0_{cell}$	-ve	+ve
D.	Electron flow	<u>From anode to cathode</u>	<u>From anode to cathode</u>
E.	Spontaneity of reaction	Non-spontaneous	spontaneous

(2 × 10 = 20 marks)

7(a) (i): 20 marks

(ii) An electrochemical cell was constructed at 300 K by using a Zn(s) anode, an aqueous alkaline electrolyte and a porous Pt cathode which facilitates the collection of oxygen  $O_2(g)$  from air as shown below. As the cell operates ZnO(s) is produced.

You are given that

$$E^{\circ}_{ZnO(s) | Zn(s) | OH^-(aq)} = -1.31 \text{ V and } E^{\circ}_{O_2(g) | OH^-(aq)} = +0.34 \text{ V}$$

$$Zn = 65 \text{ g mol}^{-1}, O = 16 \text{ g mol}^{-1} \text{ and}$$

$$1 F = 96,500 \text{ C}$$

I. Write the half-reactions occurring at anode and cathode.

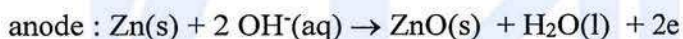
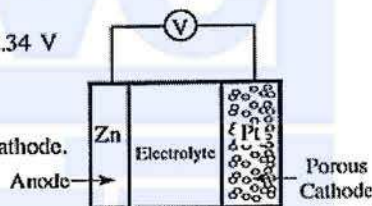

(05)



(05)

II. Write the overall cell reaction.

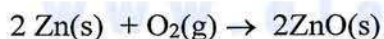

(05)

III. Calculate the cell potential  $E^{\circ}_{cell}$  at 300 K.

$$E^{\circ}_{cell} = E^{\circ}_R - E^{\circ}_L = E^{\circ}_{cathode} - E^{\circ}_{anode}$$

(05)

$$= 0.34 \text{ V} - (-1.31 \text{ V}) = 1.65 \text{ V}$$

(04+01)

IV. State the direction of migration of  $OH^-(aq)$  ions between the electrodes.

From anode to cathode (from Zn electrode to oxygen electrode)

(05)

- V. When the cell operates for a period of 800 s at 300 K, 2 mol of O<sub>2</sub>(g) are consumed.  
 A. Calculate the number of moles of electrons passing through the cell.

$$2 \text{ mol O}_2(\text{g}) \times \frac{4 \text{ mol } e^-}{1 \text{ mol O}_2(\text{g})} = 8 \text{ moles of electrons} \quad (05)$$

- B. Calculate the mass of ZnO(s) formed.

$$\text{Mass of ZnO(s)} = \frac{8 \text{ mol } e^- \times 96500 \text{ C}}{1 \text{ mol } e^- \times 800 \text{ s}} \times \frac{1 \text{ mol } e^-}{96500 \text{ C}} \times \frac{2 \text{ mol ZnO(s)}}{4 \text{ mol } e^-} \times \frac{81 \text{ g}}{1 \text{ mol ZnO}} \quad (05)$$

$$= 324 \text{ g} \quad (04+01)$$

OR

$$\text{Mass of ZnO} = 4 \text{ mol} \times 81 \text{ g mol}^{-1} \quad (05)$$

$$= 324 \text{ g} \quad (04+01)$$

- C. Calculate the current passing through the cell.

$$I = q/t \quad (05)$$

$$= \frac{8 \text{ mol } e^- \times 96500 \text{ C}}{1 \text{ mol } e^- \times 800 \text{ s}} = 965 \text{ A} \quad (05)$$

7(a) (i): 55 marks

7(a): 75 marks

- (b) A coloured complex ion **P** is formed when the salt  $M(\text{NO}_3)_n$  is dissolved in distilled water. **M** is a transition element belonging to the 3d block. **P** undergoes the following reactions.

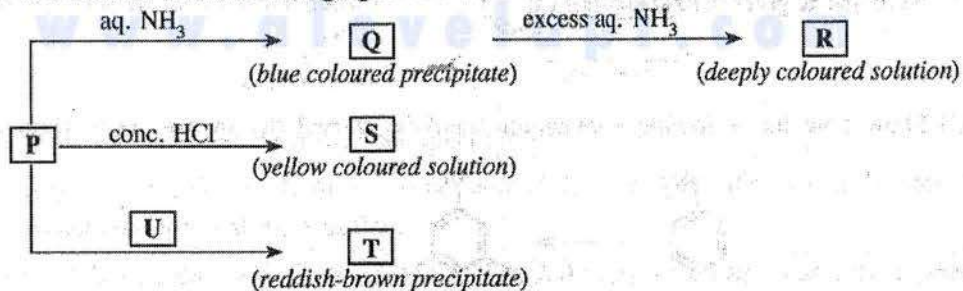

**T** and **U** are coordination compounds each containing four elements. **P**, **R** and **S** are complex ions.

- (i) Identify the metal **M**. Give the oxidation state of **M** in complex ion **P**.

$$\mathbf{M = Cu} \quad (10)$$

$$\text{Oxidation state: } +2 \text{ OR } \text{Cu}^{2+} \quad (03)$$

7(b) (i): 13 marks

(ii) Give the value of  $n$  in  $M(NO_3)_n$ .

$n = 2$  (03)

7(b) (ii): 03 marks

(iii) Write the complete electronic configuration of  $M$  in complex ion  $P$ .

$1s^2 2s^2 2p^6 3s^2 3p^6 3d^9$  (03)

7(b) (iii): 03 marks

(iv) Write the chemical formulae of  $P$ ,  $Q$ ,  $R$ ,  $S$ ,  $T$  and  $U$ .

$P$ :  $[Cu(H_2O)_6]^{2+}$  (04)

$Q$ :  $Cu(OH)_2$  (04)

$R$ :  $[Cu(NH_3)_4]^{2+}$  (04)

$S$ :  $[CuCl_4]^{2-}$  (04)

$T$ :  $Cu_2[Fe(CN)_6]$

$U$ :  $K_4[Fe(CN)_6]$

7(b) (iv): 16 marks

(v) Give the IUPAC names of  $P$ ,  $R$ ,  $S$ ,  $T$  and  $U$ .

$P$ : hexaaquacopper(II) ion (03)

$R$ : tetraamminecopper(II) ion (03)

$S$ : tetrachloridocuprate(II) ion (03)

$T$ : copper hexacyanoferrate(II)

$U$ : potassium hexacyanoferrate(II)

7(b) (v): 12 marks

(vi) What is the colour of  $P$ ?

pale blue (04)

7(b) (vi): 04 marks

(vii) What would you expect to observe in I and II given below?

I. When  $H_2S$  gas is passed into an acidic solution containing  $P$  at room temperature

black precipitate (06)

II. When the mixture obtained in I above is heated with dilute  $HNO_3$  after the removal of dissolved  $H_2S$

pale blue solution (04)

solution is turbid/ pale yellow or milky/ white precipitate (02)

or

turbid pale blue solution (06)

7(b) (vii): 12 marks

- (viii) Briefly describe a method with the aid of balanced chemical equations for determining the concentration of  $M^{n+}$  present in an aqueous solution, using the following chemicals.  $KI$ ,  $Na_2S_2O_3$  and starch. (15 marks)

Add excess  $KI$  (01)

to an aqueous solution of volume  $V_1$   $cm^3$  containing  $M^{n+}$  (01)

Here,  $M^{n+} = Cu^{2+}$

Titrate the liberated  $I_2$  (01)

with  $Na_2S_2O_3$  whose concentration is known ( $M$   $mol\ dm^{-3}$ ) (01)

with starch as the indicator (01)

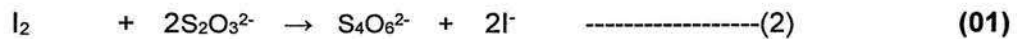
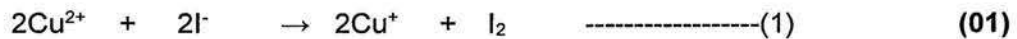

OR

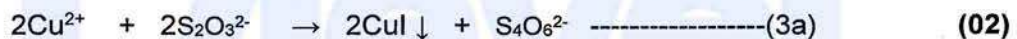
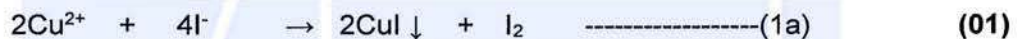

**Note: If correct overall equation is given, award the part marks for half equations as well.**

From both (3) or (3a)  $Cu^{2+} \equiv S_2O_3^{2-}$  (01)

Let the burette reading of  $S_2O_3^{2-}$  be  $V_2$   $cm^3$  (01)

Therefore, moles of  $S_2O_3^{2-}$  =  $\frac{V_2}{1000} \times M$  (01)

Therefore, moles of  $Cu^{2+}$  =  $\frac{V_2}{1000} \times M$  (01)

Therefore,  $[Cu^{2+}] = \frac{V_2}{1000} \times M \times \frac{1000}{V_1}$  (01)

=  $\frac{MV_2}{V_1} \text{ mol dm}^{-3}$  (01)

**Note: The above explanation could be given in words.**

7(b)(viii) : 15 marks

7(b): 75 marks

8. (a) (i) Given below is a reaction scheme for the synthesis of compound G using  $\text{CH}_3\text{CH}_2\text{CH}_2\text{OH}$  as the only organic starting compound. Complete the reaction scheme by drawing the structures of compounds A, B, C, D, E and F and writing the appropriate reagents for steps 1 – 7, selected only from those given in the list.

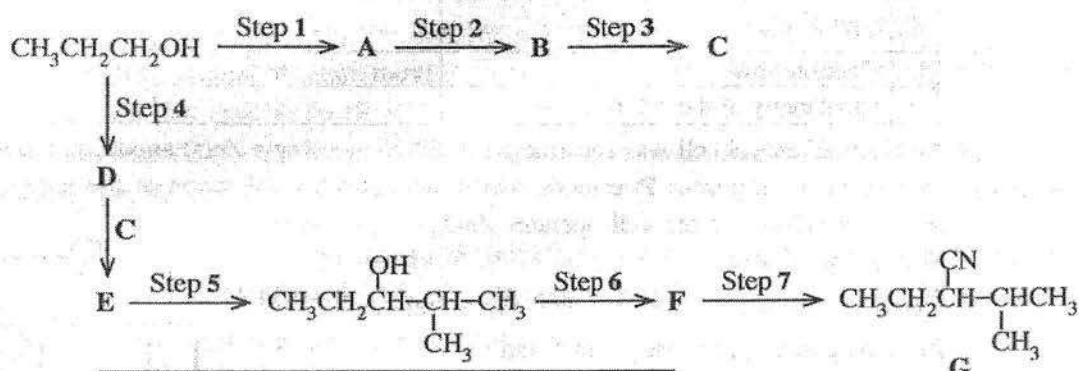

**List of Reagents**

HBr,  $\text{PBr}_3$ , pyridiniumchlorochromate (PCC),  
Mg / dry ether, KCN, conc.  $\text{H}_2\text{SO}_4$ , dil.  $\text{H}_2\text{SO}_4$

**Compounds, A - F**

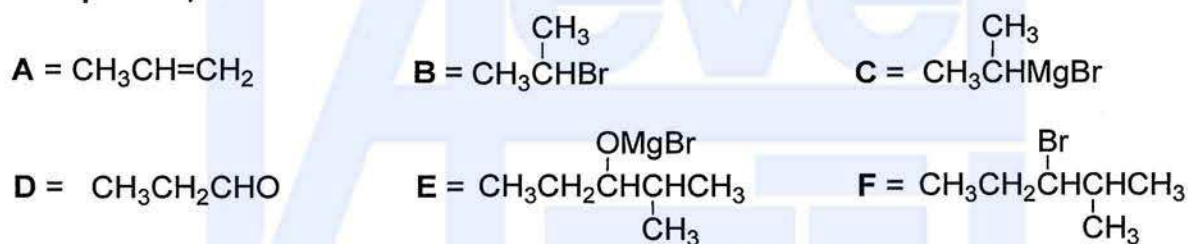

**Reagents:**

- Step 1 = conc.  $\text{H}_2\text{SO}_4$       Step 5 = dil.  $\text{H}_2\text{SO}_4$   
Step 2 = HBr      Step 6 =  $\text{PBr}_3$   
Step 3 = Mg / dry ether      Step 7 = KCN  
Step 4 = PCC

Compounds/Reagents (04 x 13 = 52 marks)

8(a) (i): 52 marks

- (ii) Consider the following series of reactions.

Draw the structures of compounds G, H and K. Give the reagents X, Y and Z.

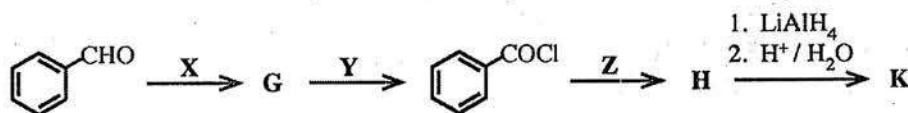

Note that K gives benzyl alcohol ( $\text{C}_6\text{H}_5\text{CH}_2\text{OH}$ ) when reacted with  $\text{NaNO}_2 / \text{dil. HCl}$ .

Compounds **G**, **H** and **K**

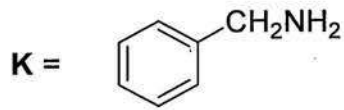
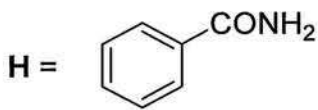
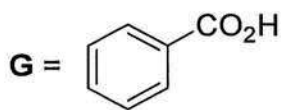

Reagents

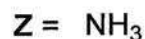
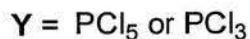
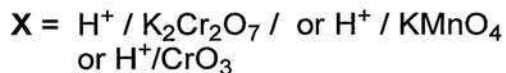

Compounds/Reagents

(04 x 6 = 24 marks)

8(a) (ii): 24 marks

8(a): 76 marks

(b) (i) Show how the following conversion could be carried out in **not more than three steps**

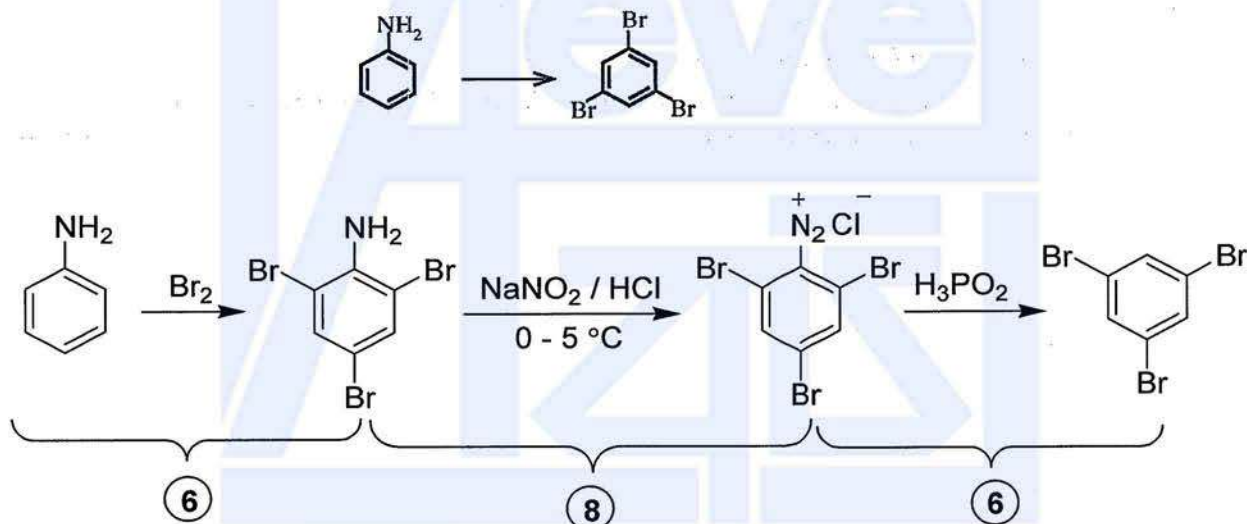

8(b) (i) 20 marks

(ii) Consider the following reaction.

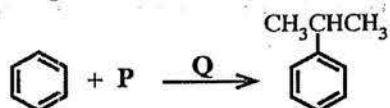

Identify the chemical substances **P** and **Q** necessary to carry out this reaction.  
Write the mechanism of this reaction.



P + Q = (05)



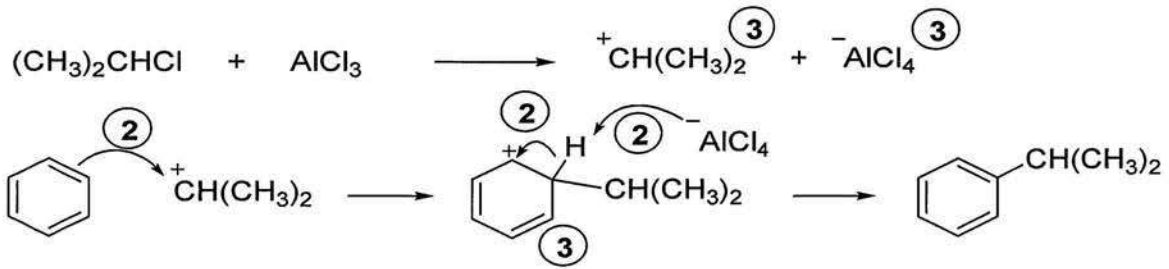

Intermediates 03 x 3 = 09  
 Arrows 02 x 3 = 06

**Alternative answer:**

IF the student has written the electrophile as R-Cl molecule polarized by coordinating to AlCl<sub>3</sub>, only the marks allocated for the last two steps may be awarded as given below.

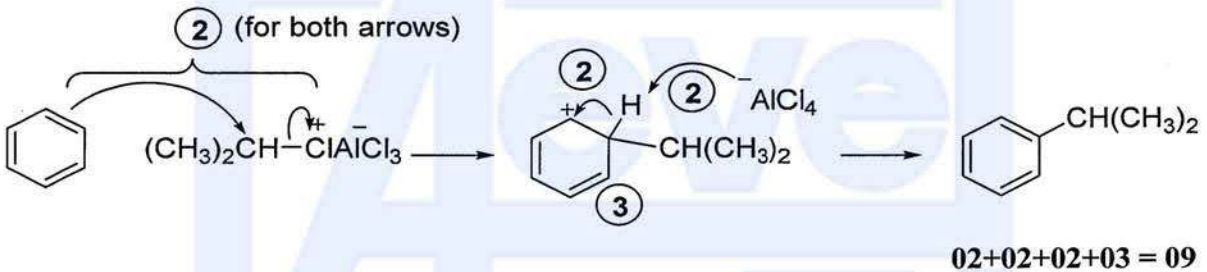

**The electrophile may be written as:**

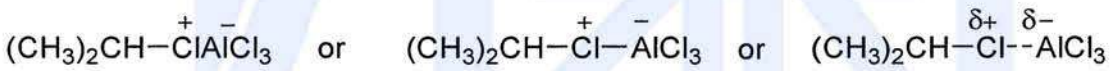

8(b)(ii): 20 marks

8(b): 40 marks

- (c) (i) Explain why phenol is more reactive in electrophilic substitution reactions than benzene, by considering their resonance hybrids.

Structures of benzene and phenol can be illustrated as follows.

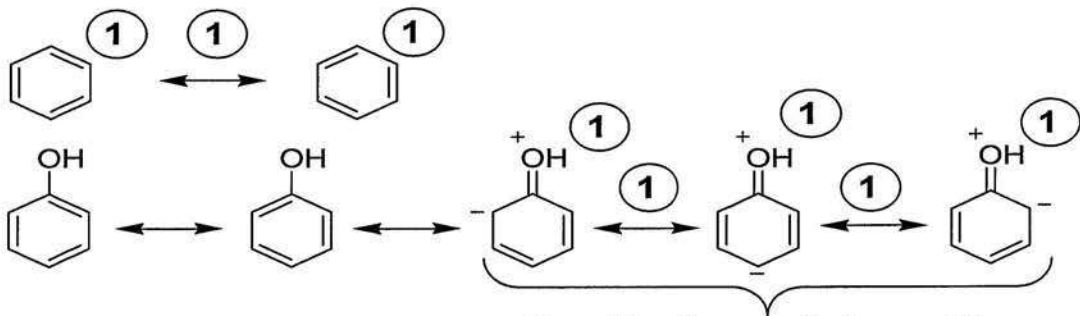

*Consider these only for marking*

Resonance structures and Double headed arrows 01 x 8 = 08

OR



Alternative to the resonance hybrid of benzene

3

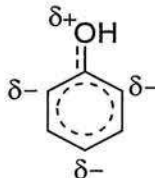
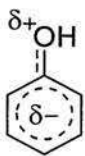
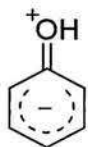
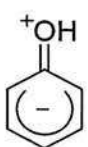

Any one structure

5

Alternative to the resonance hybrid of phenol

The benzene ring of phenol is more reactive towards electrophiles than benzene itself because:

**The benzene ring in phenol is electron rich compared to benzene due to the Delocalization of lone pair of electrons on the oxygen atom Over the benzene ring of phenol**

04 x 3 = 12

8(c)(i): 20 marks

(ii) Illustrate the difference in reactivity between phenol and benzene as given in (i) above by means of a suitable reaction.

**Phenol reacts with bromine at room temperature/ decolorizes bromine / gives a white precipitate with bromine water**

**Benzene does not react with bromine at room temperature / does not decolorize bromine / does not give a white precipitate with bromine water**

OR

**Benzene reacts with bromine (only) in the presence of a Lewis catalyst**

**Reaction of phenol with bromine occurs even in the absence of Lewis catalyst**

OR

**Nitration of phenol takes place at room temperature / at 20 °C / without heating with dilute HNO<sub>3</sub> (20% HNO<sub>3</sub>).**

**Benzene does not react with dilute HNO<sub>3</sub>**

04 x 2 = 08

8(c): (ii) 08 marks

(iii) Draw the structure(s) of product(s) you described in the reaction in (ii) above.

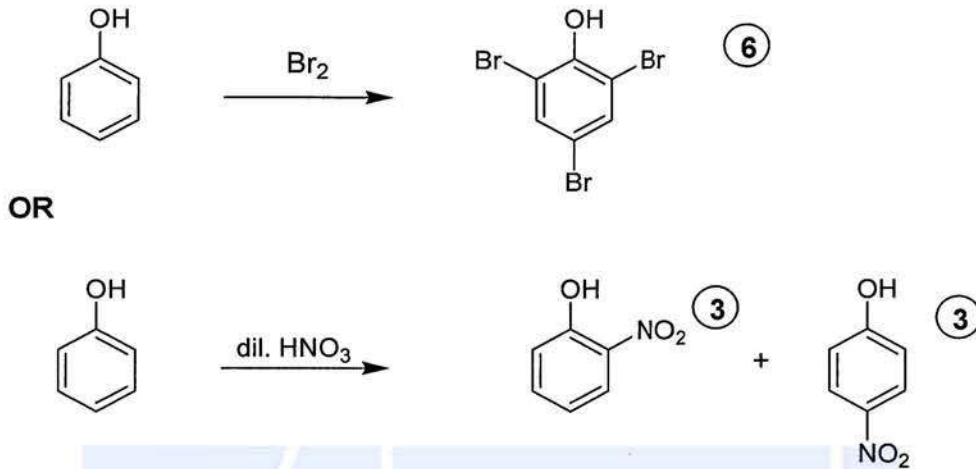

8(c) (iii): 06 marks

8(c): 34 marks

9. (a) (i) Write the chemical formulae of the substances A – Q given in the flow chart below.  
 (Note: Chemical equations and reasons are not expected for the identification of substances A – Q.)  
 The symbols given in the box (dash lines) are used to represent solids, precipitates, solutions and gases.

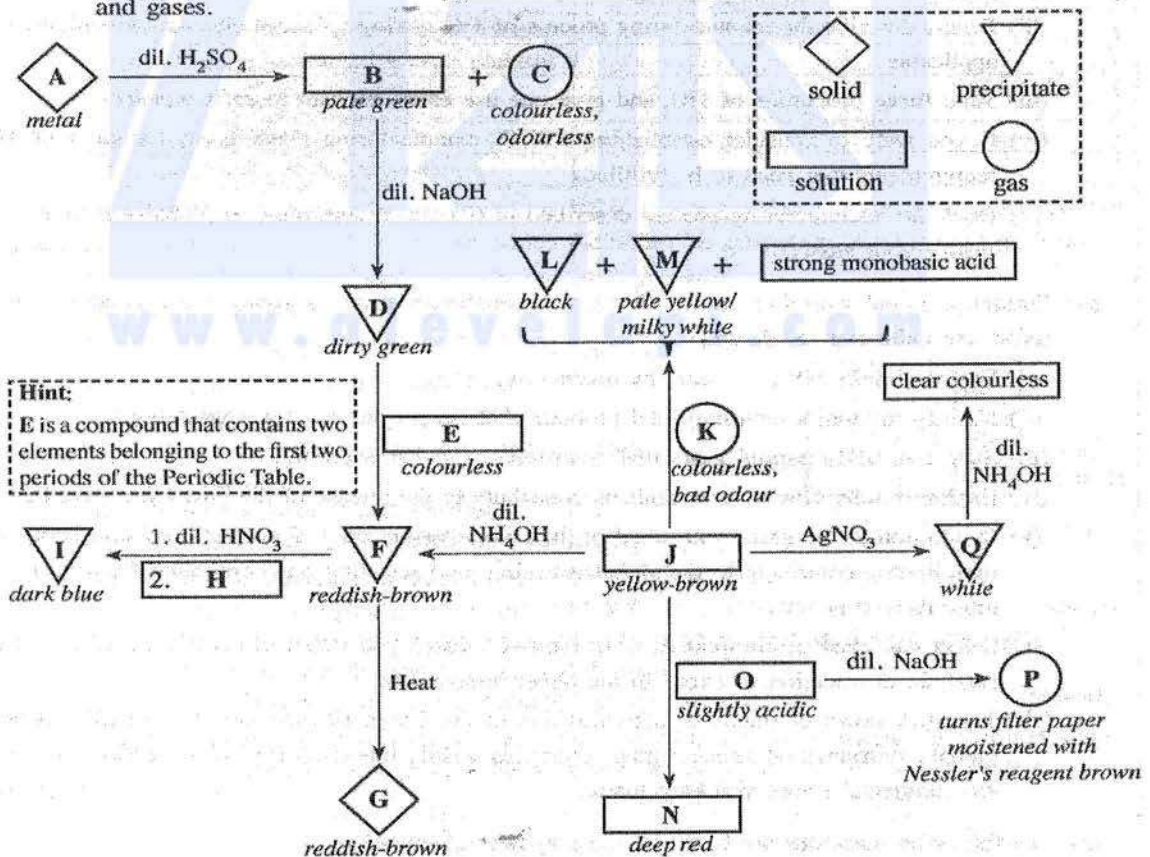

- A:** Fe                      **B:** FeSO<sub>4</sub>  
  **or**  
  [Fe(H<sub>2</sub>O)<sub>6</sub>]SO<sub>4</sub>  
  **or**  
  [Fe(H<sub>2</sub>O)<sub>6</sub>]<sup>2+</sup>
- C:** H<sub>2</sub>                      **D:** Fe(OH)<sub>2</sub>
- E:** H<sub>2</sub>O<sub>2</sub>                  **F:** Fe(OH)<sub>3</sub>                  **G:** Fe<sub>2</sub>O<sub>3</sub>                  **H:** K<sub>4</sub>[Fe(CN)<sub>6</sub>]
- I:** Fe<sub>4</sub>[Fe(CN)<sub>6</sub>]<sub>3</sub>      **J:** FeCl<sub>3</sub>                  **K:** H<sub>2</sub>S                      **L:** FeS  
  **or**  
  KFe[Fe(CN)<sub>6</sub>]
- M:** S **or** S<sub>8</sub>              **N:** Fe(SCN)<sub>3</sub>  
  **or**  
  [Fe(SCN)(H<sub>2</sub>O)<sub>5</sub>]<sup>2+</sup>  
  **or**  
  [Fe(SCN)]<sup>2+</sup>
- O:** NH<sub>4</sub>SCN              **P:** NH<sub>3</sub>

**Q:** AgCl

(04 marks x 17 = 68 marks)

9 (a) (i) : 68 marks

(ii) Write the complete electronic configuration of A.



(iii) State the function of E in the conversion of D to F. Give the relevant balanced chemical equations for the stated function.

**E:** H<sub>2</sub>O<sub>2</sub>    function – oxidizing agent (02)

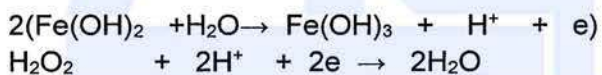

**OR**

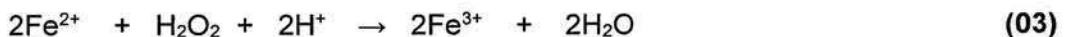
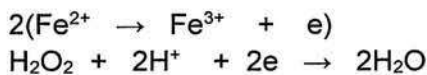

(Half reactions (01) each if written)

9 (a) (ii & iii) marks :07

9 (a) 75 marks

- (b) The solid X contains only  $\text{Cu}_2\text{S}$  and  $\text{CuS}$ . The following procedure was used to determine the percentage of  $\text{Cu}_2\text{S}$  in X.

**Procedure**

A 1.00 g portion of solid X was treated with  $100.00 \text{ cm}^3$  of  $0.16 \text{ mol dm}^{-3} \text{ KMnO}_4$  in dilute  $\text{H}_2\text{SO}_4$  medium. This reaction gave  $\text{Mn}^{2+}$ ,  $\text{Cu}^{2+}$  and  $\text{SO}_4^{2-}$  as products. Thereafter, the excess  $\text{KMnO}_4$  in this solution was titrated with  $0.15 \text{ mol dm}^{-3} \text{ Fe}^{2+}$  solution. The volume required for the titration was  $35.00 \text{ cm}^3$ .

- (i) Write the balanced ionic equations for the reactions taking place in the above procedure.

**Reaction of  $\text{Cu}_2\text{S}$  with  $\text{MnO}_4^-$**



**OR**

(1) + (2)

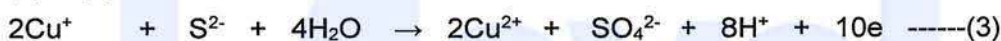

(3) + (4)



**OR**



(If only this equation is written award the full 14 marks)

**Reaction of  $\text{CuS}$  with  $\text{MnO}_4^-$**

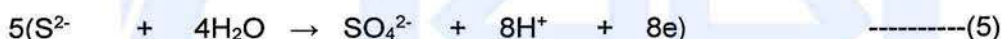

(5) + (6)

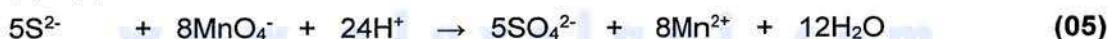

**OR**



**Reaction of  $\text{Fe}^{2+}$  with  $\text{MnO}_4^-$**



(7) + (8)

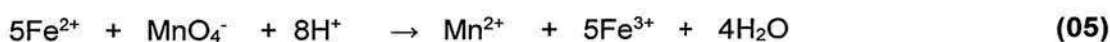

**9 (b)(i) : 27 marks**

OR

**Reaction of Cu<sup>+</sup> with MnO<sub>4</sub><sup>-</sup>**

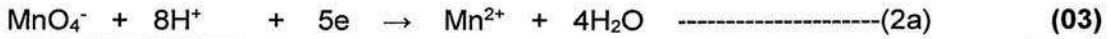

(1a) + (2a)

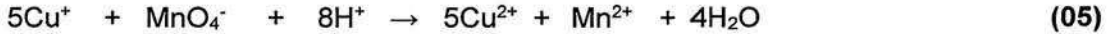

**Reaction of S<sup>2-</sup> with MnO<sub>4</sub><sup>-</sup>**



(5) + (6)



**Reaction of Fe<sup>2+</sup> with MnO<sub>4</sub><sup>-</sup>**



(7) + (8)



**Note: If only the overall reaction is written correctly, award the marks due to the half reactions as well.**

**b (b)(i): 27 marks**

(ii) Based on the answers to (i) above, determine the molar ratio between,

- I. Cu<sub>2</sub>S and KMnO<sub>4</sub>
- II. CuS and KMnO<sub>4</sub>
- III. Fe<sup>2+</sup> and KMnO<sub>4</sub>

**Molar ratios**

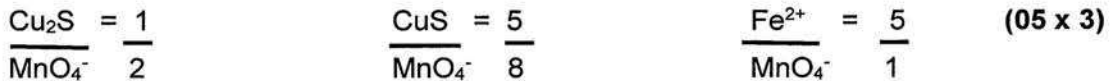

OR



**9 (b)(ii): 15 marks**

(iii) Calculate the percentage by weight of  $\text{Cu}_2\text{S}$  in X. (Cu = 63.5, S = 32)

Let the number of moles of  $\text{Cu}_2\text{S}$  and  $\text{CuS}$  be  $n_1$  and  $n_2$  respectively  
in the 1.0 g of sample X

$$\text{Molar mass of } \text{Cu}_2\text{S} = (2 \times 63.5) + 32 = 159 \quad (02)$$

$$\text{Molar mass of } \text{CuS} = 63.5 + 32 = 95.5 \quad (02)$$

$$159n_1 + 95.5n_2 = 1.0 \quad \text{-----}(9) \quad (02)$$

$$\text{Moles of } \text{Fe}^{2+} \text{ reacted} = \frac{0.15}{1000} \times 35.0 \quad (02)$$

$$\text{Moles of } \text{MnO}_4^- = \frac{0.15}{1000} \times 35.0 \times \frac{1}{5} \quad (02)$$

$$\begin{aligned} \text{Moles of } \text{MnO}_4^- \text{ reacted with } \text{Cu}_2\text{S} \text{ and } \text{CuS} \\ &= \frac{0.16}{1000} \times 100.0 - \frac{0.15}{1000} \times 35.0 \times \frac{1}{5} \quad (02) \\ &= 0.016 - 0.001 \quad (02) \\ &= 0.015 \text{ mol} \quad (02) \end{aligned}$$

Based on molar ratios

$$2n_1 + \frac{8}{5}n_2 = 0.015 \quad \text{-----}(10) \quad (02)$$

(9) + (10)

$$2n_1 + \frac{8}{5} \frac{(1-159n_1)}{95.5} = 0.015 \quad (02)$$

$$2 \times 5 \times 95.5 n_1 + 8(1-159n_1) = 0.015 \times 95.5 \times 5 \quad (02)$$

$$955n_1 + 8 - 1272n_1 = 7.1625$$

$$317n_1 = 0.84$$

$$n_1 = 0.0027 \quad (02)$$

$$\text{Weight of } \text{Cu}_2\text{S} = 0.0027 \times 159 \text{ g} \quad (02)$$

$$= 0.43 \text{ g} \quad (02)$$

$$\% \text{ Cu}_2\text{S} = \frac{0.43}{1.0} \times 100 \quad (02)$$

$$= 43\% \quad (03)$$

9 (b)(iii) : 33 marks

OR

$$\text{Moles of } \text{Fe}^{2+} = \frac{0.15}{1000} \times 35.0 \quad (02)$$

$$\text{Moles of } \text{MnO}_4^- \text{ remaining} = \frac{0.15}{1000} \times 35.0 \times \frac{1}{5} \quad (02)$$

$$\text{Moles of } \text{MnO}_4^- \text{ added} = \frac{0.16}{1000} \times 100.0 \quad (02)$$

$$\begin{aligned} \text{Moles of } \text{MnO}_4^- \text{ reacted with } \text{Cu}_2\text{S} \text{ and } \text{CuS} \\ &= \frac{0.16}{1000} \times 100.0 - \frac{0.15}{1000} \times 35.0 \times \frac{1}{5} \quad (02) \\ &= 0.016 - 0.001 \quad (02) \\ &= 0.015 \text{ mol} \quad (02) \end{aligned}$$

Consider the masses of  $\text{Cu}_2\text{S}$  and  $\text{CuS}$  to be  $p$  and  $q$  respectively.

$$p + q = 1.0 \text{ g} \quad \text{-----}(9a) \quad (02)$$

$$\text{Molar mass of } \text{Cu}_2\text{S} = (2 \times 63.5) + 32 = 159 \quad (02)$$

$$\text{Molar mass of } \text{CuS} = 63.5 + 32 = 95.5 \quad (02)$$

$$\frac{2p}{159} + \frac{8q}{95.5 \times 5} = 0.015 \quad \text{-----}(10a) \quad (02)$$

From (9a) & (10a)

$$\frac{2p}{159} + \frac{8(1-p)}{95.5 \times 5} = 0.015 \quad (02)$$

$$2p \times 5 \times 95.5 + 8 \times 159(1-p) = 0.015 \times 5 \times 159 \times 95.5 \quad (02)$$

$$955p - 1272p = 1138.84 - 1272 \quad (02)$$

$$317p = 133.16$$

$$p = \frac{133.16}{317} = 0.42 \quad (02)$$

$$\% \text{ Cu}_2\text{S} = \frac{0.42}{1000} \times 100.0 \quad (02)$$

$$= 42\% \quad (03)$$

9 (b)(iii) : 33 marks

OR

Let the number of moles of  $\text{Cu}_2\text{S}$  and  $\text{CuS}$  be  $n_1$  and  $n_2$  respectively in the 1.0 g of X



$$\text{Moles of } \text{MnO}_4^- \text{ added} = \frac{0.16}{1000} \times 100.0 = 0.016 \quad (02)$$

$$\text{Moles of } \text{Fe}^{2+} \text{ reacted} = \frac{0.15}{1000} \times 35.0 = 0.005 \quad (02)$$

$$\text{Moles of } \text{MnO}_4^- \text{ remaining} = \frac{0.15}{1000} \times 35.0 \times \frac{1}{5} = 0.001 \quad (02)$$

$$\text{Moles of } \text{MnO}_4^- \text{ reacted} = 0.016 - 0.001 = 0.015 \quad (02)$$

$$\text{Molar mass of } \text{Cu}_2\text{S} = (2 \times 63.5) + 32 = 159 \quad (02)$$

$$\text{Molar mass of } \text{CuS} = 63.5 + 32 = 95.5 \quad (02)$$

$$159n_1 + 95.5n_2 = 1 \quad \text{-----}(1) \quad (02)$$

$$\text{Moles of } \text{Cu}^+ = 2n_1$$

$$\text{Therefore, moles of } \text{MnO}_4^- \text{ reacted} = \frac{2n_1}{5}$$

$$\text{Moles of } \text{S}^{2-} = n_1 + n_2 \quad (02)$$

$$\text{Therefore, moles of } \text{MnO}_4^- \text{ reacted with } \text{S}^{2-} = \frac{8(n_1 + n_2)}{5}$$



Therefore, total moles of  $MnO_4^-$  reacted =  $\frac{10n_1 + 8n_2}{5}$  (02)

$\frac{(10n_1 + 8n_2)}{5}$  mol = 0.015 mol (02)

$10n_1 + 8n_2 = 0.075$  mol -----(2) (02)

(1) x 8 – (2) x 95.5

$1272 n_1 - 955 n_1 = 8 - 7.14$  (02)

$317n_1 = 0.86$  Therefore,  $n_1 = \frac{0.86}{317}$

Therefore, moles of  $Cu_2S$  in 1 g =  $\frac{0.86}{317}$  (02)

Mass of  $Cu_2S$  =  $0.86 \times 159$  g (02)

% of  $Cu_2S$  =  $\frac{0.86}{317} \times 159 \times 100\%$  (02)

= **43%** (03)

9 (b)(iii): 33 marks

9(b): 75 marks

10. (a) The following questions are based on the properties of titanium dioxide ( $TiO_2$ ) and its manufacture carried out by the "Chloride Process".

(i) Name the raw materials used in this process.

Rutile (02)

Coke (02)

$Cl_2$  (02)

$O_2$  (02)

10 (a) (i): 08 marks

(ii) Briefly describe the manufacturing process of  $TiO_2$  giving balanced chemical equations where applicable.

Chlorination

Removal of water at  $200\text{ }^\circ\text{C}$  /  $300\text{ }^\circ\text{C}$  (02)

Heating of rutile and coke mixture at  $900\text{ }^\circ\text{C}$  /  $950\text{ }^\circ\text{C}$  (02)



Stream of chlorine is passed over mixture of rutile and coke (02)



**OR**

Reactions (A) and (B) can be combined.

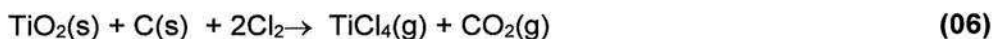

For three descriptions above (02 x 3)

After removal of dust particles,  $\text{TiCl}_4$  gaseous mixture is cooled and liquid  $\text{TiCl}_4$  is separated. (02)

Oxidation

$\text{TiCl}_4$  is reacted with oxygen and  $\text{TiO}_2$  is regenerated.



$\text{Cl}_2$  is re-used in chlorination. (02)

**10 (a) (ii): 19 marks**

(iii) State **three** properties of  $\text{TiO}_2$  and give one use each, relevant to each property.

- White colour – as a pigment in paint, plastic goods and paper, paper
- High refractive index – as a pigment
- Chemically inert – as a pigment in medicine and toothpaste
- Prevents the reach of UV rays to skin – produce substances to prevent sunburn

**Any three properties (02 x 3 = 06)**

**One use for each property (02 x 3 = 06)**

**10 (a) (iii): 12 marks**

(iv) If you were to consider establishing a  $\text{TiO}_2$  manufacturing plant in Sri Lanka, state **three** requirements that need to be fulfilled.

- Availability of raw material
- Capital
- Labour force
- Technology
- Storage conditions
- Minimize environmental pollution
- Transport facilities
- Waste product management

**Any three (02 x 3 = 06)**

**10 (a) (iv): 06 marks**

(v) Does the manufacturing process described in (ii) above contribute to global warming? Justify your answer.

Yes. (02)

$\text{CO}_2$  is produced and given out to the environment in the oxidation of coke (03)

**10 (a) (v): 05 marks**

**10(a): 50 marks**

(b) Currently, global warming due to change in greenhouse effect is significantly greater than that before the industrial revolution.

(i) Explain briefly what is meant by greenhouse effect.

**Heating of earth (01) by infrared absorbing gases (01) in the atmosphere by trapping energy (IR radiation) (02) reradiated from the earth surface (02).**

**10 (b) (i): 06 marks**

(ii) Identify the major environmental problem that occurs due to global warming.

Climate change (03)

**10 (b) (ii): 03 marks**

(iii) State **two main** natural gases that contribute to global warming.

CO<sub>2</sub>, CH<sub>4</sub>, and N<sub>2</sub>O      any two (03 + 03)

**10 (b) (iii): 06 marks**

(iv) Explain briefly how microorganisms contribute to the release of the gases you stated in (iii).

CO<sub>2</sub>- Action of aerobic bacteria on organic substances/ plant materials/ and animal materials

CH<sub>4</sub>- Action of anaerobic bacteria on organic substances/ materials

N<sub>2</sub>O- Action denitrifying bacteria on ammonia/ nitrogen fertilizers(urea)/ and nitrogen containing substances.

**Any two (04 + 04)**

**10 (b) (iv): 08 marks**

(v) In addition to the gases you stated in (iii), name **two** classes of synthetic volatile compounds that directly contribute to the global warming, and selecting one compound from each class, draw their structures.

CFC, HFC, HCFC

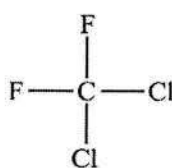

CFC,

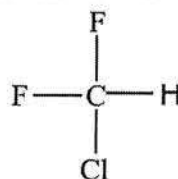

HFC,

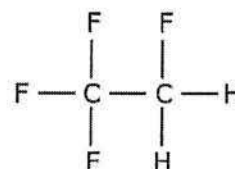

HCFC

**Any two (03 for class +03 for the structure)**

**(03 x 4 =12 marks)**

**No marks for the structure if the class is wrong**

**Note In addition to these compounds award marks for the following structures on each class.**

**CFC** - Any saturated organic compound that contain one or two carbon atoms with only Cl and F atom

**HCFC** - Any saturated organic compound that contain one or two carbon atoms with only one hydrogen atom and others are Cl and F atoms

**HFC** - Any saturated organic compound that contain one or two carbon atoms with only one hydrogen atom and others are F atoms.

**10 (b) (v): 12 marks**

(vi) Select **one** class of compounds from the two classes you stated in (v) that contributes to the catalytic degradation of ozone in the upper atmosphere.

CFC or HCFC (must be selected from (v) to get marks)

**10 (b) (vi): 03 marks**

(vii) The slow down of industrial activities due to the Covid-19 pandemic temporarily eased the global environmental issues in many countries. Justify this statement by using **two** main global environmental issues you have learnt.

**Reduction of Global warming (01):** Due to the **reduction of emission of CO<sub>2</sub> (01)** because of **reduction of fossil fuel burning (02)** due to **limitation of industrial activities (01) and transportation (01)**.

**Reduction of acid rain (01) :** **Reduction of emission of SO<sub>2</sub> (01)** into the atmosphere due to decrease of **burning of coal and diesel (01+01)** for **power generation and transportation (01+01)** respectively .

or

**Reduction of acid rain (01)** Reduction of emission of **NO<sub>2</sub>/NO into the atmosphere (01)** due to **decrease of fuel burning (01)** in **internal combustion engine (01)** of vehicles caused by limitation of **transportation (02)**.

**Reduction of Photochemical smog (01).** Reduction of emission of **NO and volatile hydrocarbons (01+01)** into the atmosphere from internal combustion engines/vehicles **(01)** due to limitation of transportation **(02)**.

**Any two (06 x 2 = 12 marks)**

**10 (b) (vii): 12 marks**

**10(b): 50 marks**

(c) The following questions are based on the polymers given below.

Polyvinyl chloride (PVC), Polyethylene (PE), Polystyrene (PS), Bakelite,  
Nylon 6,6, Polyethylene terephthalate (PET), Gutta percha

(i) Draw the repeating units of the above polymers.

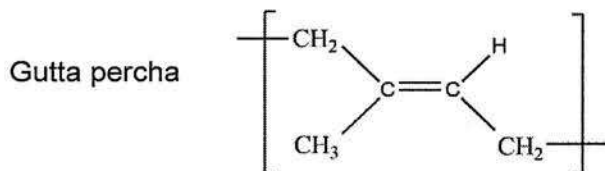
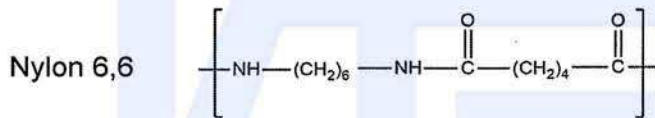
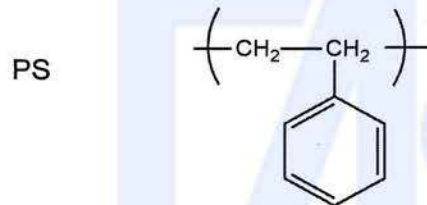
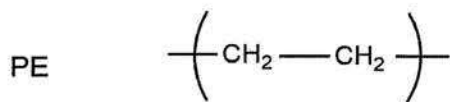
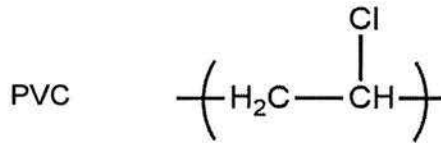

Brackets are not required for award of marks.

Any four

(02 x 4 = 08)

10 (c) (i): 08 marks

(ii) Categorize each of the above seven (7) polymers as either,

- I. natural or synthetic polymers.
- II. addition or condensation polymers.

	I - natural/synthetic	II - addition/condensation
PVC	synthetic	addition
PE	synthetic	addition
PS	synthetic	addition
Bakelite	synthetic	condensation
Nylon 6,6	synthetic	condensation
PET	synthetic	condensation
Gutta percha	natural	addition

**For I – Any 6 (02 x 6 = 12)**

**For II – Any 6 (02 x 6 = 12)**

**10 (c) (ii): 24 marks**

(iii) Name the **two** monomers used in the formation of bakelite.

phenol and formaldehyde

OR and HCHO

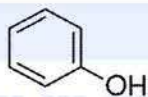

**(02 x 2 = 04)**

**10 (c) (iii): 04 marks**

(iv) Polymers can be grouped into two categories based on their thermal properties. State these **two** categories. Write to which of these categories PVC and bakelite belong.

Thermoset polymers (02)

Thermoplastic polymers (02)

Bakelite – thermoset polymer (02)

PVC – thermoplastic polymer (02)

**10 (c) (iv): 08 marks**

(v) Give **one** use each for **three** of the polymers given in the above list.

PVC	pipes to supply water, seat cover, electric wire covers
PE	food wrapping, garbage bags
PS	stylofoam cups, rigiform, insulating materials, packing materials
Bakelite	heat resistant parts for electric utensils, insulating materials
Nylon 6,6	clothes, fishing nets & lines, tyre threads
PET	bottles
Gutta percha	insulation, permanent tooth fillings, golf balls

**Any three**

**(02 x 3 = 06)**

**10(c) (v): 06 marks**

**10(c): 50 marks**

[www.alevelapi.com](http://www.alevelapi.com)